

BC Energy Step Code

Builder Guide

October 2018



Version 1.0 | Lower Steps



BRITISH
COLUMBIA



BC HOUSING
RESEARCH CENTRE



Acknowledgements

This guide was funded and commissioned by the Province of BC, BC Housing, BC Hydro, the City of Vancouver, and the City of New Westminster. Acknowledgement is extended to all those who participated in this project as part of the project team or as external reviewers.

External Reviewers and Contributors:

Architectural Institute of BC
Maura Gatensby

BC Housing
Bill MacKinnon, Deborah Kraus,
Remi Charron and Wilma Leung

BC Hydro
Bertine Stelzer, Gary Hamer,
Robyn Wark, Toby Lau

British Columbia Institute of Technology
Alexandre Hebert, Mary McWilliam

CanmetENERGY,
Natural Resources Canada
Alex Ferguson

CHBA
Jack Mantyla

CHBA BC
Vanessa Joehl

City of New Westminster
Norm Connolly

City of Vancouver
Patrick Enright, Chris Higgins

City of Richmond
Brendan McEwen, Nicholas Heap

Energy Efficiency Branch, Ministry of
Energy and Mines, Province of BC
Tom Berkhout

E3 Eco Group
Troy Glasner, Einar Halbig

Engineers & Geoscientists BC
Harshan Radhakrishnan

FortisBC
Bea Bains, Dan Bradley

Glave Communications
James Glave

Greater Vancouver Homebuilders'
Association
Mark Sakai

HCMA Architecture + Design
Johnathon Strebly, Bonnie Retief, Tiffy Riel

Integral Group
Dave Ramslie, Lisa Westerhoff

Ministry of Municipal Affairs and Housing,
Building Safety Standards Branch
Zachary May

Morrison Hershfield
Mark Lawton

National Research Council of Canada
Mihailo Mihailovic

Travelers
Don Munich

Qualico
Jonathan Meads

University of British Columbia
Ralph Wells

Urban Development Institute
Jeff Fisher, Clement Chung

4 Elements Integrated Design
Tyler Hermanson

Produced by:

RDH Building Science Inc.

James Higgins, Kimberley Wahlstrom, Elyse Henderson, Graham Finch, Torsten Ely



About this Guide

The Builder Guide to the BC Energy Step Code is published by BC Housing. This guide consolidates information on how builders may achieve the performance targets set in the BC Energy Step Code. This guide is intended to be an industry resource with respect to designing and building to the BC Energy Step Code, while not compromising other aspects of building performance including moisture management, overheating, and durability. The BC Energy Step Code is currently applicable to Part 9 residential buildings in all BC climate zones and Part 3 residential buildings in Climate Zone 4. This guide is limited to wood-frame construction and thus omits guidance for non-combustible Part 3 buildings.

This first edition of the Builder Guide includes guidance for the Lower Steps of the Step Code, while later editions will include updates for the Upper Steps (4 and 5 for Part 9 buildings, 3 and 4 for Part 3 buildings).

Disclaimer

This guide is provided for general information only. The greatest care has been taken to confirm the accuracy of the information contained herein. However, the authors, funders, publisher, and other contributors assume no liability for any damage, injury, loss, or expense that may be incurred or suffered as a result of the use of this publication, including products, building techniques, or practices. The views expressed herein do not necessarily represent those of any individual contributor, BC Housing, BC Hydro, the City of New Westminster, or the City of Vancouver.

2018 Update to the BC Energy Step Code

The requirements referenced in this guide are based on the updated metrics and targets endorsed by the BC Energy Step Code Council in September 2018. The updated Step Code is planned for implementation in December 2018.

This page is intentionally left blank

Contents

01 Introduction	1
02 How to Use This Guide	2
03 Overview of the Step Code.	3
Goals of the Step Code	3
Benefits of High-Performance Buildings.	6
Changes to the Design and Build Processes	7
Working with an Energy Modeller.	9
Step Code Metrics	11
Step Code Performance Targets Tables	16
City of Vancouver Performance Targets Tables.	23
04 Principles of High-Performance Buildings	25
Building as a System	25
Design Strategies.	29
Building Enclosure Durability	35
Thermal Comfort, Condensation and Hygiene.	36
05 Energy Performance Requirements	37
Climate Zones.	37
Example Enclosure Performance Ranges	39
Mechanical Equipment Examples for Part 9 Buildings	46
06 Assemblies	53
Overview	54
Above-Grade Walls.	55
Sloped Roof Assemblies	65
Low-Slope Roof Assemblies	72
Below-Grade Walls and Slab	79
Windows and Doors	86

07 Airtightness	91
Air Barrier as a System	91
Air Barrier Requirements	92
Air Barrier Strategies	93
Detailing	99
Air Barrier Transitions	102
08 Mechanical Equipment and Systems	107
Overview	107
Heating and Cooling	109
Ventilation	111
Domestic Hot Water	113
Auxiliary Equipment	114
09 Details	115
Windows	116
Sloped Roofs	120
Low-Slope Roofs	128
Rim Joist	132
Rim Joist at Supported Balcony	136
Below-Grade	140
Additional Resources	147
Glossary of Terms	149
Appendix A: Part 9 Step Code Compliance Report . . .	156
Appendix B: Example Step Code Flow Chart	159
Appendix C: Sample Energy Modelling Results	160
Appendix D: Mock-Up Build Instructions	185

01 Introduction

Builder Guide Web Tool

The information provided in the Builder Guide is also available as an online web tool. The interactive interface enables the users (designers, builders, and building officials) to quickly find topics relevant to their climate zone, target Step, and building type. The web tool as well as this Guide has been developed specifically for wood-frame Part 9 homes and wood-frame Part 9 and Part 3 low- and mid-rise residential buildings.

The BC Energy Step Code (herein referred to as the “Step Code”) offers a consistent provincial standard for energy efficiency requirements for new buildings. The Step Code uses tiers of performance targets, instead of prescriptive requirements such as R-value and U-value that builders may be familiar with. There is a need for education resources for builders and specifiers on this new performance-based system.

The Builder Guide to the BC Energy Step Code (herein referred to as the “Guide”) has been developed to clearly communicate the Step Code and how to achieve its performance targets. The Guide pertains to wood-frame construction of Part 9 residential buildings (≤ 3 storeys, ≤ 600 m² footprint) and Part 3 low- and mid-rise residential buildings (>3 to 6 storeys, >600 m² footprint). The target audience for the guide includes builders, designers, and building officials, although its content has been developed to be accessible to any reader with a basic knowledge of wood-frame construction and building design.

The Guide provides an overview of enclosure types, mechanical efficiencies, and design features and strategies that may be used to reach each Step within each climate zone of BC. It includes specific illustrations and descriptions of enclosure assemblies, mechanical systems, and airtightness requirements. In addition to specific measures to meet Step Code targets, the Guide also includes information on the general principles and strategies for designing energy-efficient buildings. These principles may be used more widely than for achieving the Step Code targets as they demonstrate best practices in the industry.



References to the City of Vancouver Green Buildings Policy for Rezoning (the “Policy”) are included where applicable. The rezoning policy performance targets are similar to those of the Upper Steps of the Step Code. As such, City of Vancouver callout boxes will be more prominent in later editions of the Guide that focus on the Upper Steps. Nevertheless, principles of energy-efficient design for Lower Steps are generally applicable to all energy efficiency codes.

02 How to Use This Guide

The sections of this Guide have been developed to be easily referenced individually or read in succession. This Guide can be used both to direct early design decisions, which will have a large impact on the overall energy performance of the building, and as a reference document for assemblies, components, and construction practices that should be used in buildings aiming to meet the Step Code.

The basic starting point for design decisions is identifying the building climate zone, building type, and the Step to be achieved. From there, the building energy performance targets are met with specific solutions for the enclosure assemblies, building components, and mechanical systems. Sections 3 and 4 provide general guidance. The organization of the material is shown in the flow chart below.

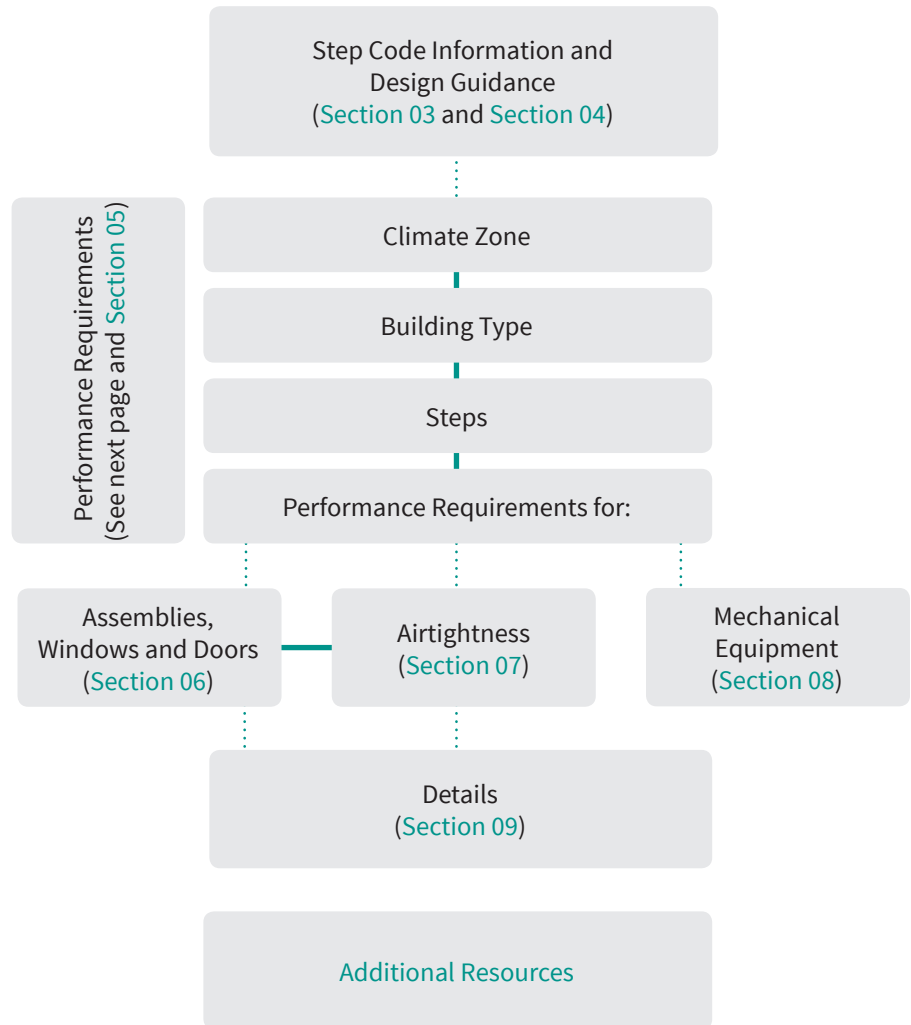

03 Overview of the Step Code

In Short

The BC Building Code has laid out a pathway to reach a net-zero energy ready target by 2032. Each step in this path requires a reduction in building energy use, increasing the performance of buildings.

High-Performance Building

A building built to high energy efficiency standards with reduced energy needs compared to today's standards.

Net-Zero Energy Ready Building

A building whose annual energy requirements are minimized and could be offset by renewable energy.

Section Includes:

- Goals of the Step Code 3
- Benefits of High-Performance Buildings 6
- Changes to the Design and Build Processes 7
- Working with an Energy Modeller 9
- Step Code Metrics. 11
- Step Code Performance Targets Tables. 16
- City of Vancouver Performance Targets Tables 23

Goals of the Step Code

The Step Code is a part BC Building Code that provides a performance-based path to support a market transformation from current energy efficiency requirements to net-zero energy ready buildings by 2032. The Province has committed to taking these incremental steps as a part of its overarching commitments to improving energy efficiency in the built environment.

The path to net-zero energy ready buildings is set out through a series of increasingly stringent requirements for energy use, thermal energy demand, and airtightness. The performance requirements that have been set were the result of a lengthy consensus-building process among a number of key stakeholders from across the province (see below), and supported by energy modelling and analysis. The process of establishing the Step Code took a period of approximately two years through the efforts of the Energy Efficiency Working Group and the Energy Step Code Council, and is still ongoing.





The City of Vancouver uses the Vancouver Building Bylaw, rather than the BC Building Code.

Version 1.0

This first edition of the Builder Guide includes guidance for the Lower Steps of the Step Code, while later editions will include updates for the Upper Steps (4 and 5 for Part 9 buildings and 4 for Part 3 buildings built with combustibles construction).

The BC Energy Step Code Applies Across the Province

One of the central purposes of the Step Code is to provide province-wide consistency in building energy and emissions policies and bylaws. As of December 15th, 2017, all authorities having jurisdiction who enforce the BC Building Code can opt to require or incentivize levels of the Step Code. No other energy efficiency program other than those listed in the BC Building Code may be enforced.

The Step Code applies to Part 9 residential buildings, with different performance requirements for each climate zone. The Step Code also currently applies to Part 3 multi-unit residential and large commercial buildings in Climate Zone 4. The requirements are set in steps, as shown in the illustrations below for residential buildings. The Step Code does not apply in the City of Vancouver. It does not apply in federal lands within the province.

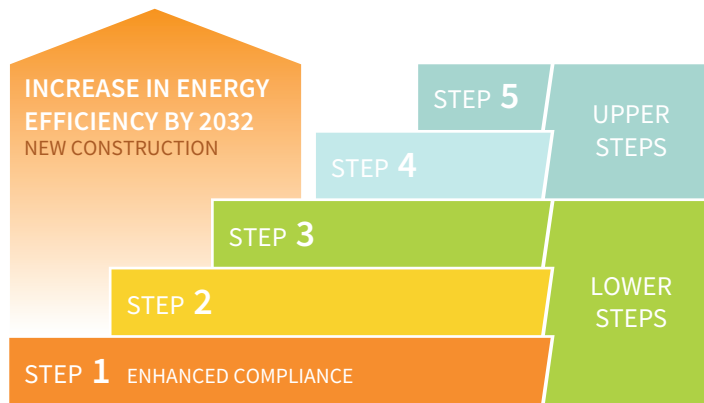

Part 9 Residential Buildings

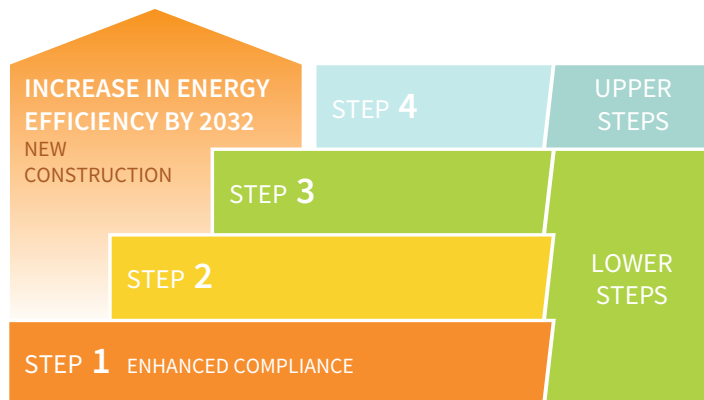

Part 3 Wood-Frame Residential Buildings

Enclosure-First Approach

An approach to reducing energy consumption and providing a comfortable indoor environment for the occupants. A key strategy in achieving high-performance buildings.

Achieving the Steps of the BC Energy Step Code

The Step Code provides a clear path to achieving net-zero energy ready buildings. An enclosure-first approach helps to minimize energy demand and enables the use of lower capacity and highly efficient mechanical equipment. Airtightness testing ensures that a continuous air barrier is considered throughout the design process, which minimizes air leakage and thus heating demand. Energy modelling is used to assess the building as a whole system to ensure that designs meet performance targets.

Designers and builders learn how to construct energy-efficient buildings through practice, including feedback from energy modelling and airtightness testing. Lower Steps are anticipated to be achieved with little to no market transformation. Mature market pricing and technology availability will develop as demand grows for better products and more efficient design strategies. The capacity for airtightness testing and energy modelling, as well as general knowledge and skills to execute high-performance buildings, will increase.

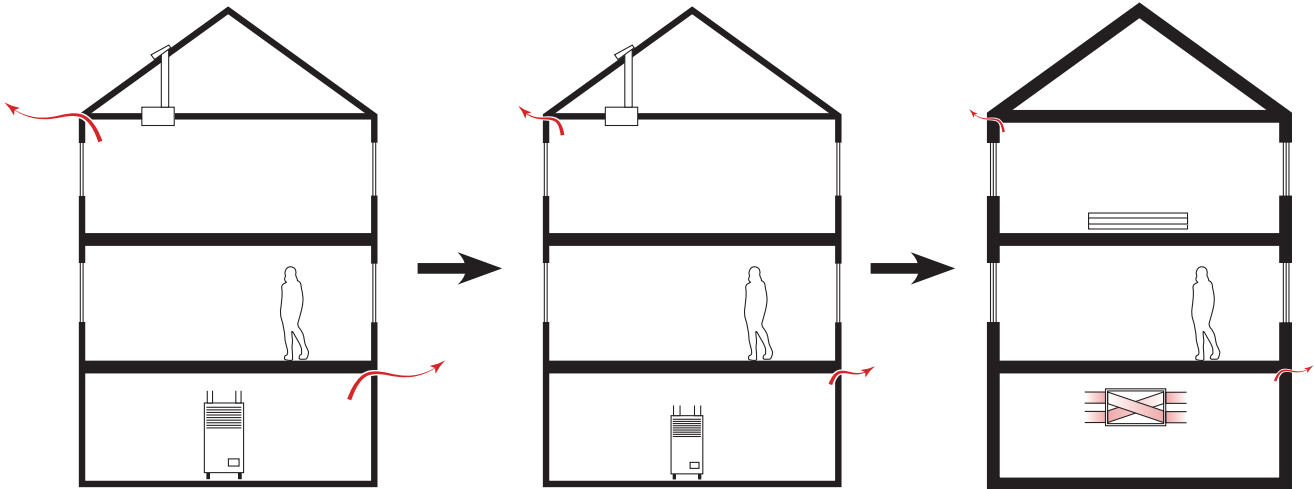

Step 1:

Designers and builders get familiar with energy modelling and airtightness testing.

Steps 2 and 3:

Improvements made to the enclosure based on lessons learned from Step 1, and mechanical systems upgrades.

Upper Steps:

High-performance buildings successfully constructed based on lessons learned from the Lower Steps and facilitated by a mature market.

High-Performance Buildings and the BC Energy Step Code

The solutions in this guide are intended to help the industry achieve energy-efficient buildings that meet the requirements of the various steps of the Step Code, and that may incorporate aspects of high-performance buildings.

While the Step Code offers a path to increasingly energy-efficient and net-zero energy ready buildings, meeting the Step Code does not necessarily mean building a high-performance building. For example, apart from complying with the Step Code, designers still need to consider thermal comfort and indoor air quality of the home.

Benefits of High-Performance Buildings

High-performance buildings greatly reduce emissions from the built environment. Other significant benefits include occupant comfort, utility cost savings, and reduce dependence on grid infrastructure in an environment with increasing storms and climate-related natural disasters.

Key features of high-performance buildings:

- › Enclosure-first approach
 - Better insulated enclosure
 - Increased airtightness
 - Optimized solar shading
- › High-efficiency HVAC
- › Heat recovery system
- › Operable vents enabling natural cross ventilation

Benefits of high-performance buildings:

- › Reduced energy consumption and the opportunity for lower utility bills
- › Improved thermal comfort:
 - Reduced drafts from air leakage
 - Stable and uniform ambient interior temperatures due to higher-performance enclosure assemblies
 - Reduced cooling load and potential for overheating with solar shading strategies optimized to block the summer sun
- › Improved indoor air quality:
 - Continuously ventilated and filtered air with the use of heat recovery ventilators
 - Reduced risk of mould growth caused by condensation
- › Lower greenhouse gas emissions:
 - Less combustion of fossil fuels and lower demand for electricity generation (and corresponding environmental impacts)
- › Climate adaptation/climate change resilience
 - High-performance enclosures withstand the effects of drastic seasonal temperatures
 - Less dependence on grid infrastructure increases public safety during times of crisis and natural disasters
 - Carbon abatement from lower emissions may slow the effects of climate change

Changes to the Design and Build Processes

Current Compliance for Part 9 Buildings

Prescriptive path: Building to be designed and constructed to comply with the prescriptive requirements in BCBC Subsections 9.36.2. to 9.36.4.,

or

Performance path: Use the parameters set out in 9.36.5 to complete an energy modelling for the building and design and construct it to achieve the same energy performance as a reference house which is generated by using Subsections 9.36.2. to 9.36.4.

Step 1 Compliance

Building to be designed and constructed to comply to the % Lower than Reference House performance target as set out in 9.36.6. Both energy modelling and airtightness testing are required.

Step 2-5 Compliance

Building to be designed and constructed to comply with the Step Code performance targets. The targets include airtightness requirements, maximum energy used by the building equipment and systems, and maximum thermal energy demand. Energy modelling and airtightness testing is required, and the construction must be revised for compliance if the energy targets are not met.

Design and Build Process | Part 9 Buildings

Builders for Part 9 construction can move from the option to follow the prescriptive- or performance-based requirements in Subsections 9.36.2. to 9.36.5. of the BCBC, toward the performance-based Step Code as defined by subsection 9.36.6. The key changes to this process are the requirements for energy modelling and airtightness testing. Builders that may have used BCBC 9.36.5. or the EnerGuide Rating System in the past will already be familiar with the energy modelling requirements set out in Subsection 9.36.6.

Current Compliance



Step 1 Compliance

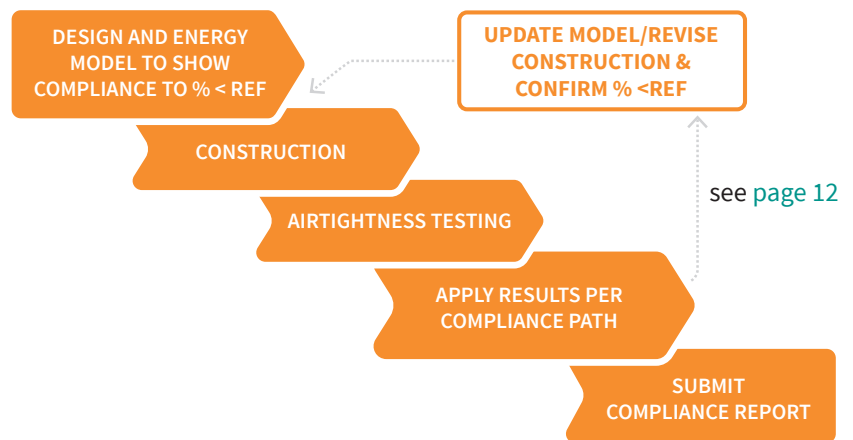

Step 2-5 Compliance

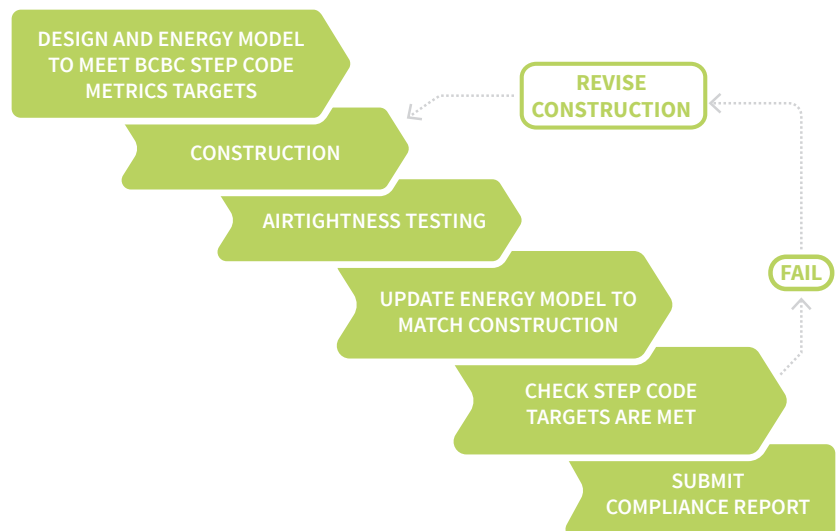

Design and Build Process | Part 3 Buildings

Current Compliance for Part 3 Buildings

Building to be designed and constructed per NECB or ASHRAE 90.1 using either the prescriptive path, trade off path, or performance path.

Step 1 Compliance

Building to be designed and constructed to comply with NECB using whole building energy modelling and a reference model as described in Part 8. Airtightness testing, an as-built energy model, and reporting is required.

Step 2-4 Compliance

Building to be designed and constructed to comply with the Step Code targets using whole building energy modelling. Airtightness testing, an as-built energy model, and reporting is required. The as-built energy model must show that the building, with the as-tested airtightness value, complies with the Step Code targets. The construction may need to be revised for compliance if the energy targets are not met.

Developers for Part 3 buildings will transition from the various compliance paths in either the NECB or ASHRAE 90.1, to those of the Step Code. Step 1 requires the use of the performance path in Part 8 of NECB. ASHRAE 90.1 is not a compliance path in the Step Code. Steps 2-4 implement Step Code performance targets instead of comparison to a reference model. Airtightness testing and reporting is also required in all steps to determine the as-built building airtightness.

Current Compliance



Step 1 Compliance

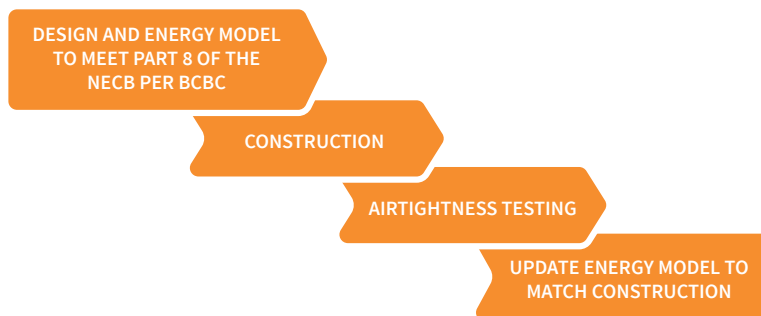

Step 2-4 Compliance

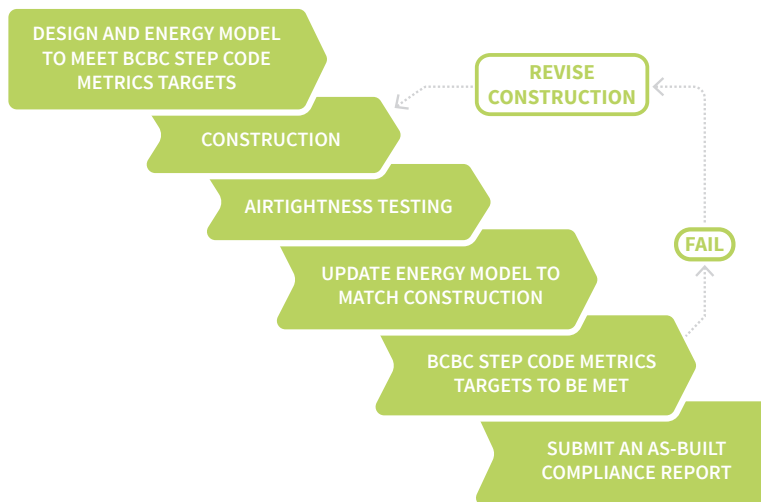

Working with an Energy Modeller

Energy Modelling

Energy modelling must be carried out in all steps of the Step Code for both Part 9 and Part 3 buildings.

The Step Code has introduced mandatory energy modelling at all steps for all building types. Many projects have used modelling in the past, for example to comply with energy efficiency programs such as R-2000 or ENERGY STAR, or for code compliance using the performance path options. For builders and developers who followed the prescriptive compliance pathways before the Step Code, the integration of energy modelling into the design process may be new.

Energy modelling is integral to confirming that the design meets the targeted performance requirements. There are also other benefits to performing whole building energy modelling such as assessing which design measures have the most or least impact on energy performance. As such, modelling can be used to refine designs and find the most cost-effective approach for achieving a desired outcome. The modelling outputs for heating demand are also useful for sizing mechanical systems and preventing oversizing equipment.

Energy modelling guidelines must be followed to have consistency between projects. In addition to the applicable requirements of Part 8 of NECB, the current version of the City of Vancouver Energy Modelling Guidelines must be followed for the modelling of Part 3 buildings. The measured air leakage rate must also be included in the model, although a temporary value may be used until the airtightness testing is complete.

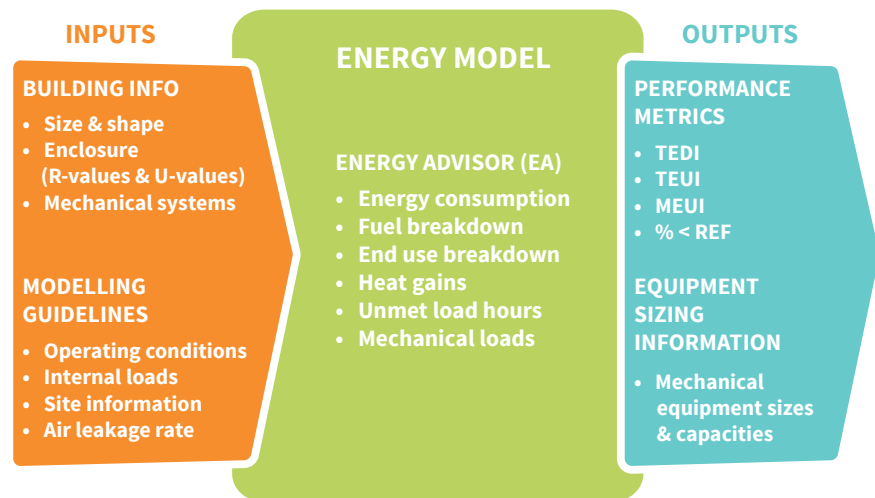

Airtightness Testing

Whole-building airtightness testing is required in all steps of the Step Code. This work requires coordination across all members of the design and construction team.

See the *Illustrated Guide - Achieving Airtight Buildings* published by BC Housing for more information on whole-building airtightness testing.



Airtightness Testing

Whole-building airtightness testing is completed using blower fans to pressurize and depressurize the building. The various measured results of testing, including fan airflow and pressure difference across the enclosure, are used to indicate the overall building airtightness characteristics and performance level. The steps required vary depending on building type and size, and the test standard being used, but generally are as follows:

1. Select Test Standard

The CAN/CGSB 149.10, ASTM E 779, or USACE Version 3 test standards can be used for airtightness testing.

2. Pre-Test Planning

Determine test boundary and calculate building areas and volume. Determine which openings need to be sealed, as well as the fan capacity and location, and coordinate building preparation.

3. Test Preparation

The building must be prepared before testing. This can often be the most labor-intensive step. The air barrier must be complete before testing can occur. Seal all openings as required, close all exterior doors and windows, and fill plumbing traps. Turn off combustion and ventilation equipment. On the day of the test, check that weather conditions are within the allowable range. Install fans, pressure taps, sensors, and controls, and ensure there is a “single-zone” condition for the test volume.

4. Airtightness Test

Use the test software and measure fan airflow and pressure across the building enclosure per the test standard. Regularly check the results for accuracy, and repeat for positive and negative pressure if required.

5. Fail - Repair / Diagnostics

If the results do not meet the design requirements, improve the air barrier to meet code and/or energy model requirements and retest if needed. Use diagnostics tools like a smoke tracer or thermography to identify air leakage locations.

6. Reset Building

Remove all temporary seals, turn the mechanical equipment back on.

7. Report

Report all test results as required by the test standard. The BCBC requires that as-tested building airtightness be included with the building drawings and specifications. Check with the local authority having jurisdiction if they require any specific reporting requirements.









Step Code Metrics

Overview of the Step Code performance requirements

The key performance metrics of the Step Code may be separated into three categories:

- airtightness,
- equipment and systems, and
- building enclosure.

The airtightness and building enclosure metrics direct the building design toward an enclosure-first approach, which is integral to minimizing heating demand. The equipment and systems metrics consider the total energy consumption of the building. The performance metrics for Part 9 and Part 3 buildings have some overlap, but there are also slight differences. This section provides more detail on the individual Part 9 and Part 3 metrics as well as area of conditioned space, which is used to calculate most of the metrics.

Building Type	Airtightness	Equipment and Systems	Building Enclosure
 Part 9		 OR  % < REF MEUI	 TEDI
 Part 3		 TEUI	 TEDI
	<p>Airtightness has been determined as the single most cost-effective way to reduce heating energy consumption, and thus testing and reporting is required at all steps and for all building types. Specific targets have been set for Steps 2-5 for Part 9 buildings. For Part 3 buildings there are no airtightness targets, however, the tested airtightness is required to be included in the as-built energy model to determine compliance with the TEDI target.</p>	<p>The metrics for equipment and systems are slightly different for Part 9 and Part 3 buildings. The Part 9 metrics, Mechanical Energy Use Intensity (MEUI) and % lower than Reference House (% < REF), include the energy consumption from HVAC systems and domestic hot water (DHW), pumps, and fans, but omit base loads such as plug loads and lighting. The Part 3 metric, Total Energy Use Intensity (TEUI), includes plug loads and lighting as well as all HVAC, DHW systems and other auxiliary systems such as elevators and miscellaneous equipment.</p>	<p>The building enclosure metric, Thermal Energy Demand Intensity (TEDI), is the same for Part 9 and Part 3 buildings. This metric directs the building design toward an enclosure-first approach, which is integral to minimizing heating demand. TEDI is a measure of the annual heating demand and considers the energy gains and losses through the enclosure, internal heat gains and heat recovery efficiencies.</p>



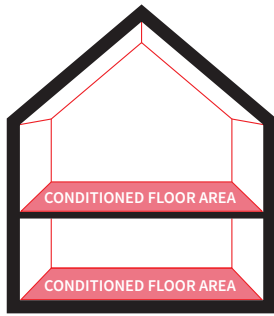

The area of conditioned space includes all floor areas within the thermal building enclosure.

Area of Conditioned Space | Part 9 and Part 3 Buildings

The Step Code metrics normalize (divide) the buildings annual energy use over the floor area of conditioned space. The area of conditioned space includes all floor areas within the thermal building enclosure. The International System of Units is used, thus area is measured in square metres (m²). It is good practice to use the floor area from the energy model for all metrics calculations.

$$\text{Step Code Metrics} = \frac{\text{Annual Energy Consumption}}{\text{Area of Conditioned Space}} = \frac{\text{kWh}}{\text{m}^2 \cdot \text{year}}$$



Airtightness | Part 9 and Part 3 Buildings

Airtightness is a metric used throughout the industry to measure how much air leaks in or out of a building enclosure, commonly referred to as “air leakage rate”. The requirements are slightly different for Part 9 and Part 3 buildings as described below.

Where airtightness is determined in accordance with the prescriptive testing standards with intentional openings for mechanical equipment left unsealed, the airtightness rate must be adjusted in the energy model calculations to account for air leakage through mechanical equipment.

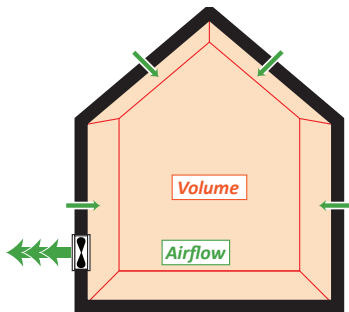

Part 9 buildings must meet performance targets prescribed by the Step Code.

Part 9 Buildings

For Part 9 buildings airtightness is measured in air changes per hour (ACH) and shall be tested to an induced test pressure of not less than 50 Pa and in accordance with Article BCBC 9.36.6.5., which lists the acceptable airtightness testing standards.

Step 1 Airtightness Compliance

While there are no prescriptive minimum Part 9 airtightness requirements for Step 1, there are two basic compliance pathways for target airtightness and how testing results are used, based on the energy modelling method used (see next page):

1. The EnerGuide Rating System (ERS) reference house uses 2.5 ACH₅₀ as its baseline reference air leakage rate. This target must be met, unless other offsetting energy performance improvements are achieved. The ERS building energy model must always include the as-built airtightness.
2. The 9.36.5 reference house uses 2.5 ACH₅₀ as its baseline reference air leakage rate. However, the 9.36.5 proposed house sets the assumed building air leakage rate at 4.5 ACH₅₀ for homes with enclosures built in accordance with Section 9.25., and 3.5 ACH₅₀ for homes with enclosures built in accordance with Subsection 9.25.3. and the prescriptive air barrier requirements of Articles 9.36.2.9. and 9.36.2.10. In either case the airtightness must still be tested and reported. Note that the as-built air leakage rate can be used for the building energy model if the energy performance targets of Step 1 are met.



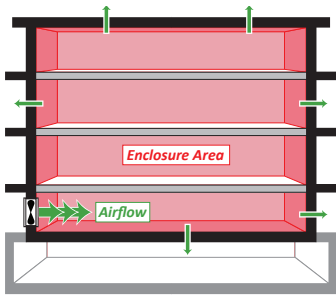

Part 3 building airtightness testing results must be used in the energy model to confirm Step Code compliance in Steps 2-4, and for reporting in Step 1.

Part 3 buildings

For Part 3 buildings, airtightness shall be tested to an induced test pressure of not less than 75 Pa and in accordance with Article BCBC 10.2.3.5, which lists two acceptable airtightness testing standards.

While no specific maximum air leakage rate is given for Part 3 buildings, these buildings must still meet the performance requirements for the enclosure air barrier. The measured airtightness value must be used in the as-built energy model.

Equipment and Systems

All three equipment and systems metrics address the energy used by the building over one year normalized per conditioned floor area (kWh/(m²·year)), however include slightly different components and energy modelling paths. The Part 9 metrics, % lower than Reference House (% < REF) and Mechanical Energy Use Intensity (MEUI), include the energy consumption from HVAC systems, including domestic hot water (DHW), pumps, and fans, but omit base loads such as plug loads and lighting. The Part 3 metric, Total Energy Use Intensity (TEUI), includes plug loads and lighting as well as all HVAC systems and other auxiliary systems such as elevators and miscellaneous equipment. For Part 9 buildings there are two metrics (two paths) that may be used for compliance, and for Part 3 buildings there is only one.

Part 9 Equipment and Systems Metrics

There are two equipment and systems metrics for Part 9 buildings. Buildings can be designed and energy modelled to meet either the % < REF metric OR the MEUI metric, with two exceptions; for Step 1 compliance the % < Ref metric must be used, and for Step 5 compliance the MEUI metric must be used.

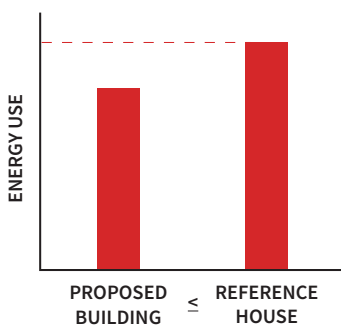

% Lower than Reference House (% < REF)

The % Lower than Reference House (% < REF) metric uses comparative analysis of the proposed buildings mechanical energy use intensity versus that of a reference building (reference house). The mechanical energy use of the reference building and the proposed building is determined by energy modelling following any one of three methods:

1. By using Natural Resource Canada's EnerGuide rating system (version 15 or newer) and HOT2000 software (version 11.5 or newer) which develops an automatically-generated reference house. The EnerGuide assumed electric base loads are to be excluded from the energy consumption for both the proposed building and the reference house.
2. By following BCBC Subsection 9.36.5.



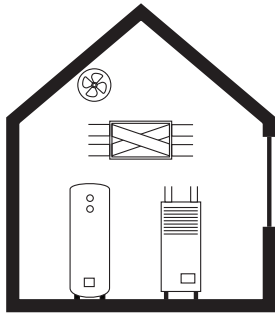

MEUI excludes electrical loads such as miscellaneous receptacles and lighting.

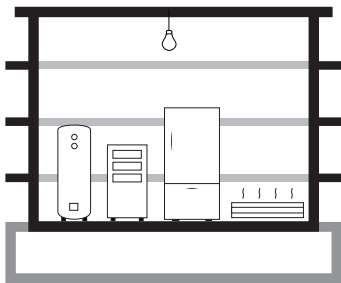

TEUI includes electrical loads such as miscellaneous receptacles and Lighting.

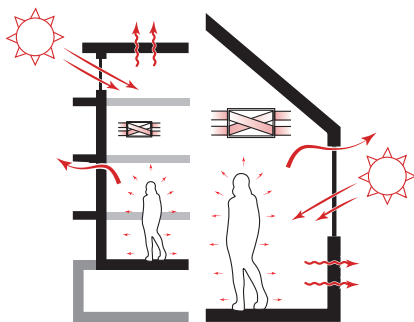

TEDI considers the same factors for Part 9 and Part 3 buildings.



Mechanical Energy Use Intensity (MEUI)

Mechanical Energy Use Intensity (MEUI) is the metric for mechanical and systems energy use over a year. It is estimated by using an energy model in accordance with BCBC Article 9.36.6.4., normalized per square metre of area of conditioned space, and expressed in kWh/(m²·year). The MEUI includes space heating and space cooling, fans, service water heating equipment, pumps, and auxiliary HVAC equipment.

The MEUI metric includes additional allowances for buildings with floor areas equal to or less than 210 m² (2357 ft²) as small houses would otherwise have difficulties meeting the targets. Additional allowances are also provided for buildings which include cooling systems to remove a barrier to provide cooling where it is necessary.

Part 3 Equipment and Systems Metric



Total Energy Use Intensity (TEUI)

Total Energy Use Intensity (TEUI) is the metric of total energy use over a year, estimated using an energy model in accordance with BCBC Article 10.2.3.4., normalized per square metre of area of conditioned space and expressed in kWh/(m²·year). Mechanical equipment included in the TEUI are space heating, space cooling, fans, service water heating equipment, pumps, auxiliary HVAC equipment, as well as miscellaneous receptacles and appliances, and lighting.

Auxiliary HVAC equipment generally includes cooling towers fans, humidifiers and other devices that do not directly fall under one of the other categories listed in Sentence 8.4.2.2.(1) of the NECB.

Building Enclosure Metric | Part 9 and Part 3 Buildings



Thermal Energy Demand Intensity (TEDI)

The Thermal Energy Demand Intensity (TEDI) metric addresses energy gains and losses through the building enclosure. TEDI limits the annual heating required by the building for space conditioning and for conditioning of ventilation air, estimated by using an energy model, normalized per square metre of area of conditioned space and expressed in kWh/(m²·year). TEDI considers thermal transmittance of the building enclosure components (including assemblies, windows, doors and skylights), solar heat gains through building enclosure components, air leakage through the air barrier system, internal heat gains from occupants and equipment, and heat recovery from exhaust ventilation.

Part 9 Buildings - Energy model in accordance with BCBC Article 9.36.6.4.

Part 3 Buildings - Energy model in accordance with BCBC Article 10.2.3.4



Additional Metrics







Greenhouse Gas Intensity (GHGI)

The Greenhouse Gas Intensity (GHGI) is the total greenhouse gas emissions associated with the use of all energy utilities on site. Although not in the Step Code, the City of Vancouver uses this additional metric for its rezoning requirements as well as a for the performance compliance path for new 4-6 storey construction in the 2018 VBBL. This metric is calculated using the energy consumption from the energy model, multiplied by the emission factors in the City of Vancouver Energy Modelling Guidelines for each respective fuel type. The metric is reported using kg of equivalent CO₂ emissions per square metre of area of conditioned space and expressed in kg CO₂e/(m²·year).



 Requirements For Part 9 Buildings Located In Climate Zone 4 (see [page 37](#))









	Airtightness  Air changes per hour at 50 Pa pressure differential	Equipment & Systems  OR  % < REF OR MEUI			Building Enclosure  TEDI (kWh/(m ² ·year))
STEP 1		0%			
STEP 2	≤ 3.0	10%	OR	see below	35
STEP 3	≤ 2.5	20%	OR	see below	30
STEP 4*	≤ 1.5	40%	OR	see below	20
STEP 5*	≤ 1.0			see below	15

 **MEUI Targets per Building Size and Whether the Building is Designed and Constructed with or without a Cooling System (kWh/(m²·year))**

	≤ 50 m ² (538 ft ²)	≤ 75 m ² (807 ft ²)	≤ 120 m ² (1292 ft ²)	≤ 165 m ² (1776 ft ²)	≤ 210 m ² (2357 ft ²)	> 210 m ² (2357 ft ²)
Buildings Designed and Constructed with No Cooling System						
STEP 2	135	120	90	75	65	60
STEP 3	120	100	75	63	53	50
STEP 4*	90	80	60	48	40	40
STEP 5*	65	55	40	30	25	25
Buildings Designed and Constructed with Cooling System						
STEP 2	170	148	108	85	73	65
STEP 3	155	128	93	73	60	55
STEP 4*	125	108	78	58	48	45
STEP 5*	100	83	58	40	33	30

* Solutions to the Upper Steps will be included in a later version of this guide.







 Requirements For Part 9 Buildings Located In Climate Zone 5 (see page 37)							
	Airtightness  Air changes per hour at 50 Pa pressure differential		Equipment & Systems  OR  % < REF MEUI			Building Enclosure  TEDI (kWh/(m ² ·year))	
STEP 1			0%				
STEP 2	≤ 3.0		10% OR see below			45	
STEP 3	≤ 2.5		20% OR see below			40	
STEP 4*	≤ 1.5		40% OR see below			30	
STEP 5*	≤ 1.0		 see below			20	
 MEUI Targets per Building Size and Whether the Building is Designed and Constructed with or without a Cooling System (kWh/(m²·year))							
	≤ 50 m ² (538 ft ²)	≤ 75 m ² (807 ft ²)	≤ 120 m ² (1292 ft ²)	≤ 165 m ² (1776 ft ²)	≤ 210 m ² (2357 ft ²)	> 210 m ² (2357 ft ²)	
Buildings Designed and Constructed with No Cooling System							
STEP 2	145	130	100	85	75	70	
STEP 3	135	115	90	78	68	65	
STEP 4*	100	90	70	58	50	50	
STEP 5*	70	60	45	35	30	30	
Buildings Designed and Constructed with Cooling System							
STEP 2	180	158	118	95	83	75	
STEP 3	170	143	108	88	75	70	
STEP 4*	135	118	88	68	58	55	
STEP 5*	105	88	63	45	38	35	

* Solutions to the Upper Steps will be included in a later version of this guide.



 Requirements For Part 9 Buildings Located In Climate Zone 6 (see [page 37](#))







	Airtightness  Air changes per hour at 50 Pa pressure differential	Equipment & Systems  OR  % < REF MEUI			Building Enclosure  TEDI (kWh/(m ² ·year))
STEP 1		0%			
STEP 2	≤ 3.0	10%	OR	see below	60
STEP 3	≤ 2.5	20%	OR	see below	50
STEP 4*	≤ 1.5	40%	OR	see below	40
STEP 5*	≤ 1.0			see below	25

 **MEUI Targets per Building Size and Whether the Building is Designed and Constructed with or without a Cooling System (kWh/(m²·year))**

	≤ 50 m ² (538 ft ²)	≤ 75 m ² (807 ft ²)	≤ 120 m ² (1292 ft ²)	≤ 165 m ² (1776 ft ²)	≤ 210 m ² (2357 ft ²)	> 210 m ² (2357 ft ²)
Buildings Designed and Constructed with No Cooling System						
STEP 2	160	145	115	100	90	85
STEP 3	145	125	100	88	78	75
STEP 4*	105	95	75	63	55	55
STEP 5*	80	70	55	45	40	40
Buildings Designed and Constructed with Cooling System						
STEP 2	195	173	133	110	98	90
STEP 3	180	153	118	98	85	80
STEP 4*	140	123	93	73	63	60
STEP 5*	115	98	73	55	48	45

* Solutions to the Upper Steps will be included in a later version of this guide.







 Requirements For Part 9 Buildings Located In Climate Zone 7A (see page 37)						
	Airtightness  Air changes per hour at 50 Pa pressure differential	Equipment & Systems  OR  % < REF MEUI			Building Enclosure  TEDI (kWh/(m ² ·year))	
STEP 1		0%				
STEP 2	≤ 3.0	10%	OR	see below		80
STEP 3	≤ 2.5	20%	OR	see below		70
STEP 4*	≤ 1.5	40%	OR	see below		55
STEP 5*	≤ 1.0			see below		35
 MEUI Targets per Building Size and Whether the Building is Designed and Constructed with or without a Cooling System (kWh/(m²·year))						
	≤ 50 m ² (538 ft ²)	≤ 75 m ² (807 ft ²)	≤ 120 m ² (1292 ft ²)	≤ 165 m ² (1776 ft ²)	≤ 210 m ² (2357 ft ²)	> 210 m ² (2357 ft ²)
Buildings Designed and Constructed with No Cooling System						
STEP 2	185	170	140	125	115	110
STEP 3	165	145	120	108	98	95
STEP 4*	120	110	90	78	70	70
STEP 5*	95	85	70	60	55	55
Buildings Designed and Constructed with Cooling System						
STEP 2	220	198	158	135	123	115
STEP 3	200	173	138	118	105	100
STEP 4*	155	138	108	88	78	75
STEP 5*	130	113	88	70	63	60

* Solutions to the Upper Steps will be included in a later version of this guide.



 Requirements For Part 9 Buildings Located In Climate Zone 7B (see [page 37](#))









	Airtightness  Air changes per hour at 50 Pa pressure differential	Equipment & Systems  OR  % < REF MEUI			Building Enclosure  TEDI (kWh/(m ² ·year))
STEP 1		0%			
STEP 2	≤ 3.0	10%	OR	see below	100
STEP 3	≤ 2.5	20%	OR	see below	90
STEP 4*	≤ 1.5	40%	OR	see below	65
STEP 5*	≤ 1.0			see below	50

 **MEUI Targets per Building Size and Whether the Building is Designed and Constructed with or without a Cooling System (kWh/(m²·year))**

	≤ 50 m ² (538 ft ²)	≤ 75 m ² (807 ft ²)	≤ 120 m ² (1292 ft ²)	≤ 165 m ² (1776 ft ²)	≤ 210 m ² (2357 ft ²)	> 210 m ² (2357 ft ²)
Buildings Designed and Constructed with No Cooling System						
STEP 2	205	190	160	145	135	130
STEP 3	185	165	140	128	118	115
STEP 4*	135	125	105	93	85	85
STEP 5*	105	95	80	70	65	65
Buildings Designed and Constructed with Cooling System						
STEP 2	240	218	178	155	143	135
STEP 3	220	193	158	138	125	120
STEP 4*	170	153	123	103	93	90
STEP 5*	140	123	98	80	73	70

* Solutions to the Upper Steps will be included in a later version of this guide.



 Requirements For Part 9 Buildings Located In Climate Zone 8 (see page 37)							
	Airtightness  Air changes per hour at 50 Pa pressure differential		Equipment & Systems  OR  % < REF MEUI			Building Enclosure  TEDI (kWh/(m ² ·year))	
STEP 1			0%				
STEP 2	≤ 3.0		10% OR see below			120	
STEP 3	≤ 2.5		20% OR see below			105	
STEP 4*	≤ 1.5		40% OR see below			80	
STEP 5*	≤ 1.0		 see below			60	
 MEUI Targets per Building Size and Whether the Building is Designed and Constructed with or without a Cooling System (kWh/(m²·year))							
	≤ 50 m ² (538 ft ²)	≤ 75 m ² (807 ft ²)	≤ 120 m ² (1292 ft ²)	≤ 165 m ² (1776 ft ²)	≤ 210 m ² (2357 ft ²)	> 210 m ² (2357 ft ²)	
Buildings Designed and Constructed with No Cooling System							
STEP 2	225	210	180	165	155	150	
STEP 3	200	180	155	143	133	130	
STEP 4*	150	140	120	108	100	100	
STEP 5*	115	105	90	80	75	75	
Buildings Designed and Constructed with Cooling System							
STEP 2	260	238	198	175	163	155	
STEP 3	235	208	173	153	140	135	
STEP 4*	185	168	138	118	108	105	
STEP 5*	150	133	108	90	83	80	

* Solutions to the Upper Steps will be included in a later version of this guide.







Part 3 Airtightness Testing

Part 3 buildings are required to perform airtightness testing and to use the measured air leakage rate in the energy model. There are currently no specific airtightness targets for Part 3 buildings, although better airtightness will facilitate the ability to meet the energy performance targets.



Requirements For Part 3 Residential Buildings Located In Climate Zone 4 (see [page 37](#))
(Based on BCBC Table 10.2.3.3.A)

	Equipment & Systems	Building Enclosure
	 TEUI (kWh/(m ² -year))	 TEDI (kWh/(m ² -year))
STEP 1	Conform to Part 8 of the NECB	
STEP 2	130	45
STEP 3	120	30
STEP 4*	100	15



* Solutions to the Upper Steps will be included in a later versions of this guide.





City of Vancouver Rezoning Targets (2017)



Performance Requirements for Part 3 Residential Low-rise Buildings (<7 Storeys)

	Equipment & Systems  TEUI (kWh/(m ² ·year))	Building Enclosure  TEDI (kWh/(m ² ·year))	Greenhouse Gas Intensity  GHGI CO ₂ e/(m ² ·year)	
Not connected to a City-recognized Low Carbon Energy System	100	15	5	CoV targets are aligned with Step 4 of the Step Code for Part 3 residential low-rise buildings
Connected to a City-recognized Low Carbon Energy System	110	25	5	



City of Vancouver VBBL 2018 (for non-rezoning projects)

Performance Requirements for Part 3 Residential 4-6 Storey Buildings

	Equipment & Systems  TEUI (kWh/(m ² ·year))	Building Enclosure  TEDI (kWh/(m ² ·year))	Greenhouse Gas Intensity  GHGI CO ₂ e/(m ² ·year)	
	110	25	5.5	



This page is intentionally left blank

04 Principles of High-Performance Buildings

In Short

All the parts of the house including its contents and occupants interact together to form an integrated system. This is imperative to understand when designing high-performance buildings.

High-Performance Buildings Have:

- › Low thermal transmittance
- › Low air leakage
- › Solar control
- › Low energy use and cost

Low Performance Buildings Have:

- › High thermal transmittance
- › High air leakage
- › No solar control
- › High energy use and cost

The various elements and components of the building enclosure serve as critical barriers, functioning to control the elements and separate the interior from the exterior environment.

Section Includes:

- Building as a System 25
- Design Strategies 29
- Building Enclosure Durability 35
- Thermal Comfort, Condensation and Hygiene 36

Building as a System

A building is made up of numerous parts, including the building enclosure, the structure, interior finishes, mechanical equipment, and electrical and lighting, which all interact with each other to form a system. The relationship between ventilation, thermal performance and space conditioning should be evaluated to ensure thermal comfort throughout the year. When designing high-performance buildings, an enclosure-first approach is commonly chosen. This entails a highly insulated and airtight building enclosure. This strategy reduces heat loss during the heating season and heat gain in the cooling season. Coupled with solar control, it reduces the demand on heating and cooling equipment. Heat Recovery Ventilators (HRVs) are typically incorporated into high-performance buildings to ensure healthy ventilation rates while recovering the heat from the air leaving the building.

The building enclosure, also called the building envelope, is itself a system of materials, components, and assemblies which together physically separate the interior environment of a building from the exterior. It is comprised of assemblies and components which in combination control air and heat flow through the building enclosure. For durability, safety, and occupant comfort and health, the assemblies and components must also control liquid water, water vapour, sound, fire, and smoke.

Building enclosure assemblies (roofs, walls, and floors) typically use a series of layers, each intended to serve one or more functions within the building enclosure. The insulation and air barrier materials are intended to provide the most direct control of energy flow through the building enclosure. Components (windows, doors and skylights) should be installed with the use of accessories, such as tapes and sealants, to provide continuous airtightness and protect from water ingress. The durability aspects of the building enclosure is discussed further in [Building Enclosure Durability on page 35](#).



Note on Ventilation

Mechanical ventilation is always required, even if the building uses natural ventilation through windows during the non-heating season. Mechanical ventilation may include dedicated exhaust fans, makeup air inlets at the heating equipment, or a dedicated HRV system.

Air Barrier and Ventilation Systems

The air barrier system resists uncontrolled air movement between the interior and exterior spaces. A major pathway for heat loss can be air leakage through the enclosure, where interior conditioned air escapes or exterior air infiltrates. Both airflow mechanisms can account for a significant portion of energy use in a home. Air leakage can also cause durability issues due to moisture in the assembly.

With increased airtightness comes an increased need for effective mechanical ventilation to keep the indoor environment healthy for the occupants. The interior air quality may be poor if the ventilation air is not well controlled. Heat recovery ventilators (HRVs) are recommended to be incorporated into high-performance buildings as they bring in air through filters to remove contaminants while recovering the energy from the exhaust air. Section 9.32. of the BCBC includes specific requirements for ventilation of Part 9 homes, including the use of HRVs. Part 3 buildings require a professional mechanical designer to design the building ventilation system in accordance with Section 6.3. of the BCBC.

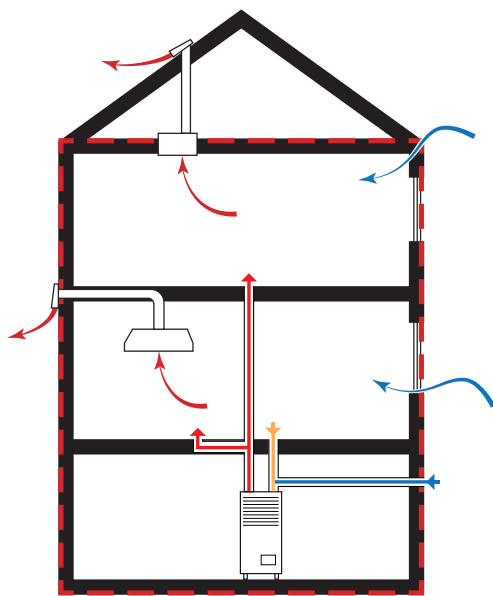

Low Performance Building

Some ventilation through fresh air intake
=
Low thermal performance

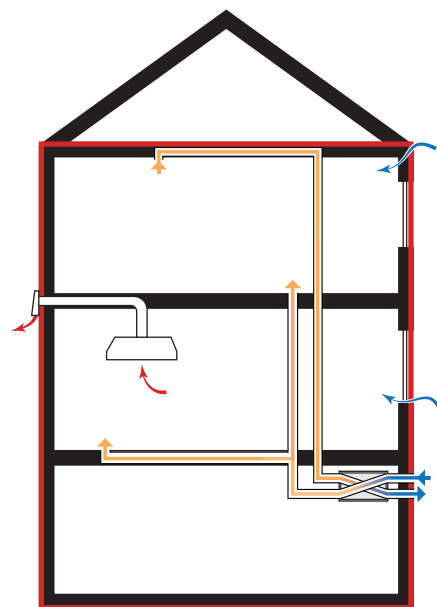

High-Performance Building

Airtight enclosure and mechanical
ventilation with or without heat recovery
=
High thermal performance



Thermal Performance and Mechanical Equipment & Systems

The building enclosure resists heat flow using materials with a low thermal conductivity (i.e. high thermal resistance). The measure of the resistance to heat flow in opaque assemblies is generally expressed in the metric units of **RSI** ($\text{m}^2\cdot\text{K}/\text{W}$) and the imperial measurement of **R-value** ($\text{ft}^2\cdot^\circ\text{F}\cdot\text{hr}/\text{Btu}$). The measure of heat loss through enclosure components like windows and doors is often expressed in the metric units of **USI** ($\text{W}/\text{m}^2\cdot\text{K}$) and the imperial measurement of **U-value** ($\text{Btu}/\text{ft}^2\cdot^\circ\text{F}\cdot\text{hr}$). The more insulation in the assembly, the higher the assembly R-value and the greater its resistance to heat flow. Conversely, the lower the U-value, the lower the heat loss through the component.

The mechanical system of a home includes heating and ventilation, and potentially cooling. They are particularly important in the context of energy efficiency. One of the main goals of the enclosure-first approach is to reduce energy loss through the enclosure and thus reduce space heating (and cooling) needs. The mechanical equipment itself can also be used to reduce the heating and cooling needs. As noted, HRVs are commonly incorporated into high-performance buildings.

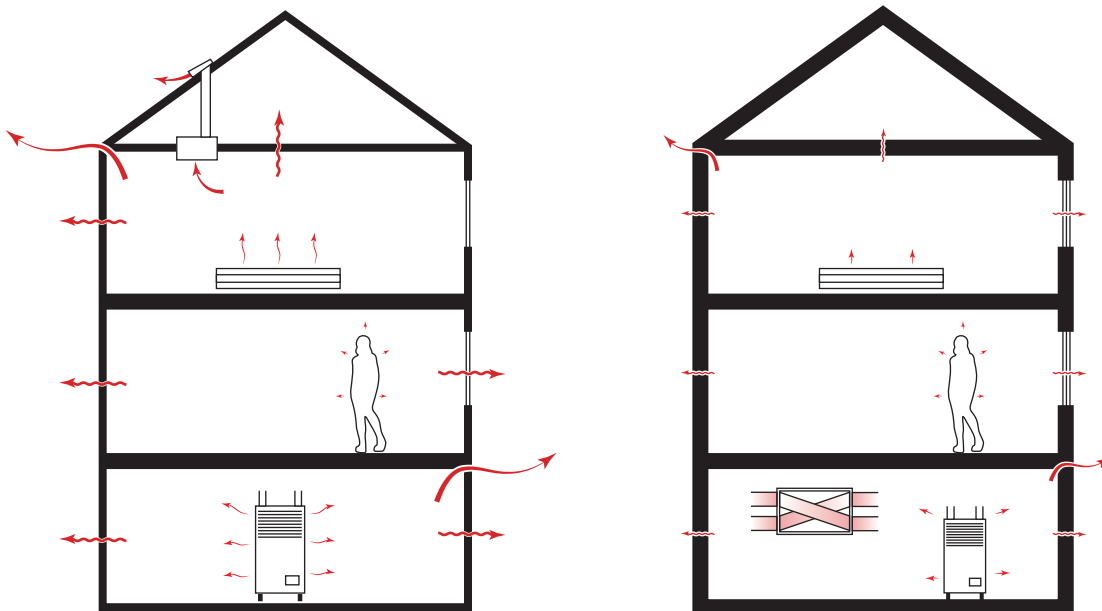

Low Performance Building

High thermal transmittance
=
Low thermal performance

High-Performance Building

Low thermal transmittance
=
High thermal performance



Solar Control

Solar control should be considered for windows and glazing exposed to direct or reflected sunlight to reduce potential overheating and cooling equipment needs. The potential for overheating varies by building, climate zone, and exposure. Various strategies to reduce overheating are discussed in [Design Strategies on page 29](#), which include glazing options and shading. The section also outlines the potential benefits of allowing sunlight to reach windows and glazing in the heating season.

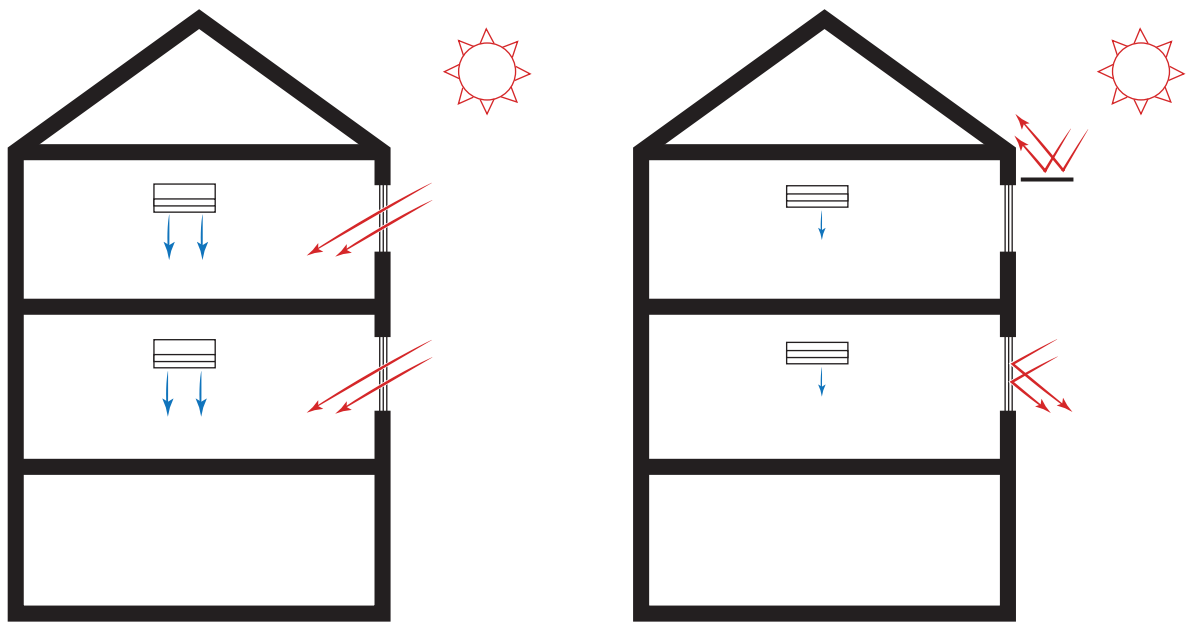

Low Performance Building

No solar control

=

Potentially overheating in summer, significant mechanical cooling may be required

High-Performance Building

Solar control

=

Reduces cooling requirement and reduces risk of overheating



Design Strategies

There are several design strategies which can be incorporated into the design of high-performance energy-efficient buildings, from early in the schematic design phase (through building form, solar exposure and solar control) to design development (building assemblies, components and details). The following is an overview of various design strategies which can be used to help reach the desired targets.

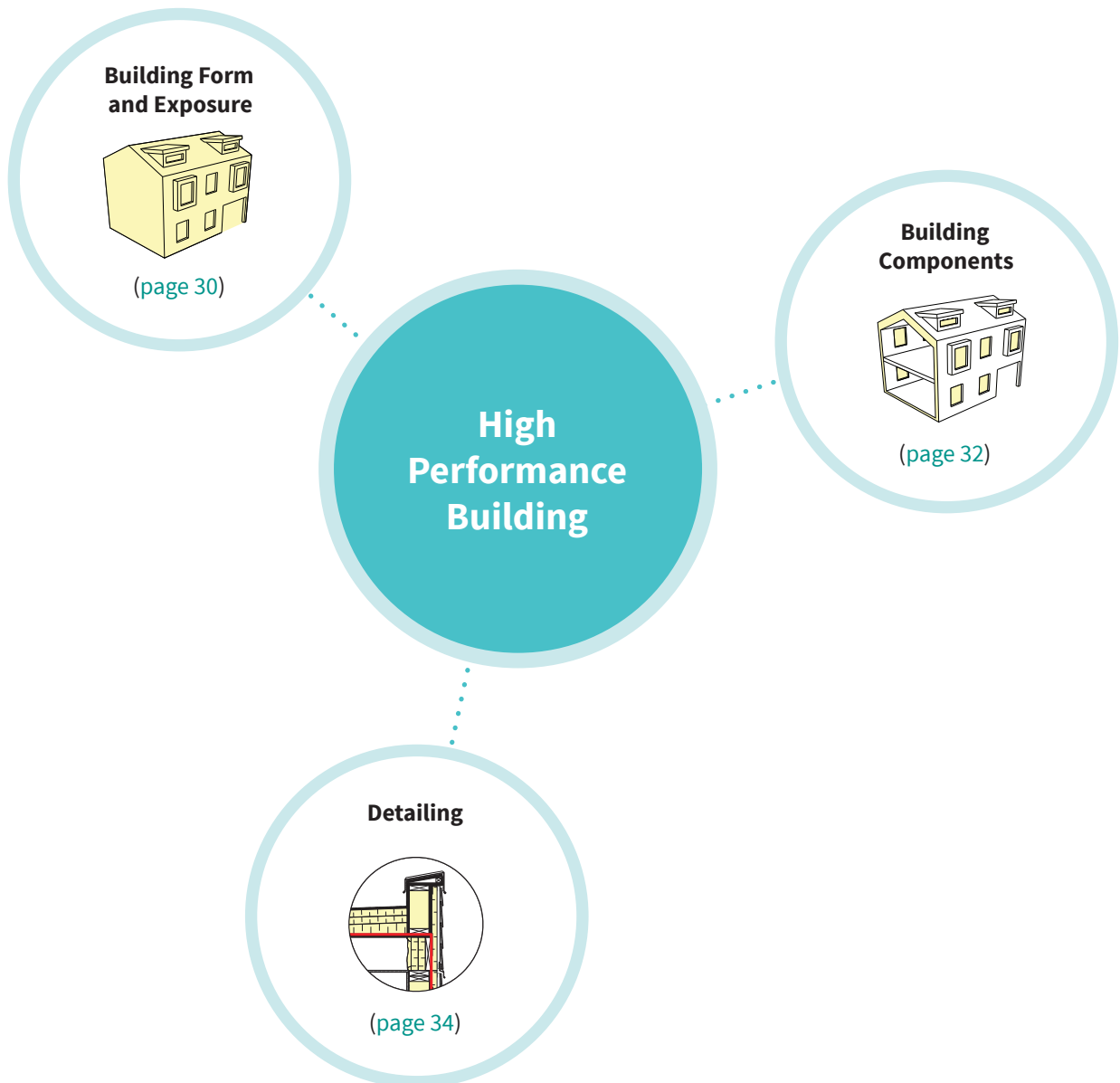

Building Form and Exposure

Form Factor

Form factor refers to a building’s overall shape, form and size. A building’s massing is central to the achievement of TEDI targets, in that the more complex a building shape, the greater the number of opportunities for heat loss through the enclosure. A building with several complex junctions and corners will lose far more heat through the enclosure than a building that has been designed as a simple, solid form.

Form factor can also be assessed in terms of a building’s vertical surface area to floor area ratio (VFAR). A lower VFAR indicates a lower overall potential for heat loss through the enclosure, as buildings’ vertical surfaces (e.g. walls) tend to have lower R-values than vertical surfaces (e.g. roofs). Higher VFAR values are often a function of the building’s floor plate size, as well as the level of articulation or complexity.

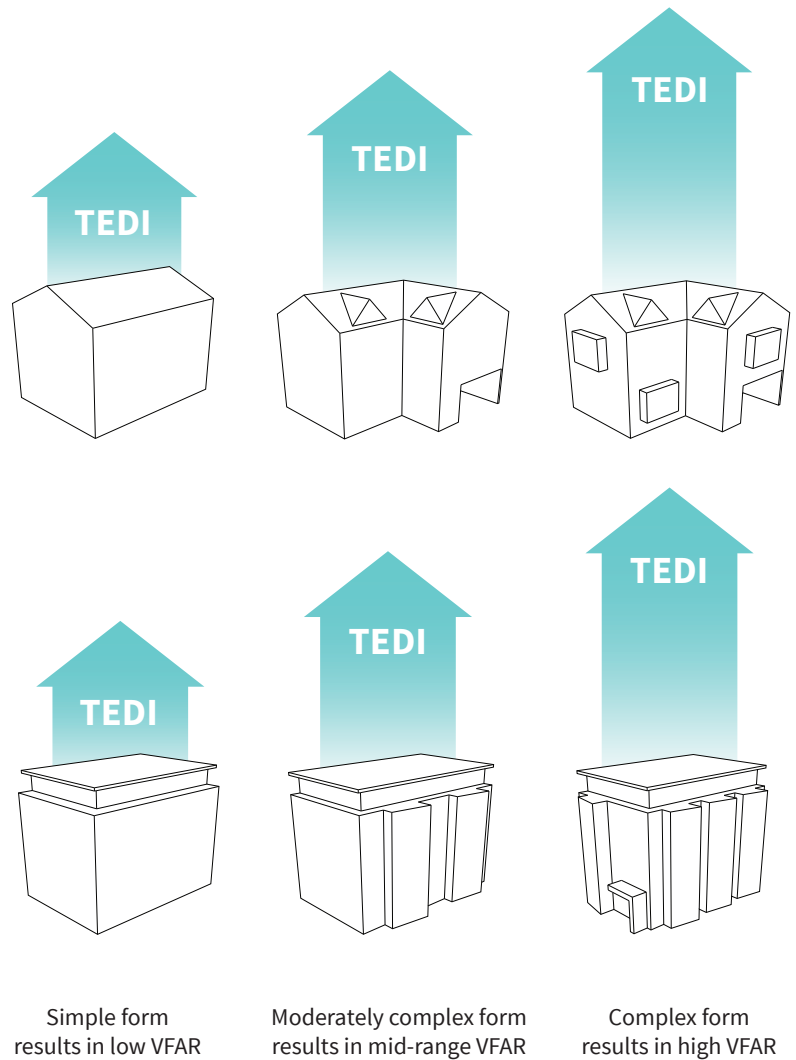

$$\text{Vertical Surface Area to Floor Area Ratio (VFAR)} = \frac{\text{Surface area of vertical enclosure}}{\text{Building floor area}}$$



Building Form and Exposure

Solar Orientation

Orientation refers to the alignment of a building's principal axis. Buildings that are oriented to maximize the potential for solar gains through glazing from the south can reduce heating demands. This strategy does not reduce heat losses, but makes use of passive heat gains which may help achieve the TEDI requirements. Building orientation can also be used to reduce lighting needs by taking advantage of natural light, which can help to achieve TEUI targets as well.

To maximize the potential for solar gains, the longest façade of a building should be oriented to face as close to due south as possible. Ideally, the south facing façade should be within 30 degrees in either direction (east or west) of due south. While many sites are constrained by existing lots and street grids, there are still opportunities to orient the upper floors of a building to the south.

Solar shading strategies should be incorporated into the design to avoid overheating in summer (see [page 33](#)).

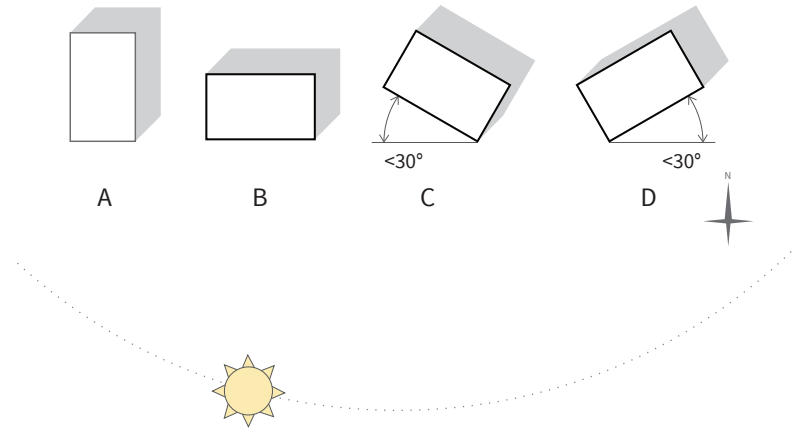

- A Non-optimal solar orientation for accessing solar gains since the building's long axis is not facing south
- B Optimal solar orientation for receiving passive solar gains since the building's long axis is facing south
- C+D Optimal solar orientation may still be achieved with the building's long axis facing within 30° of south

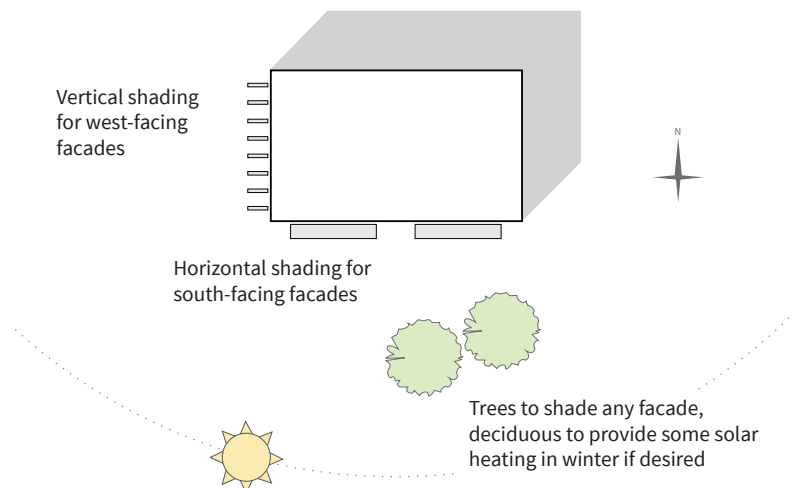

Refer to [Windows and Shading on page 33](#) for more guidance on shading strategies to avoid overheating



Building Components

Enclosure-First Approach

The enclosure-first approach reduces energy consumption and provides a comfortable indoor environment for the occupants. A key strategy in achieving high-performance buildings is the use of well-insulated assemblies. These assemblies use insulation with minimal thermal bridging to resist heat loss or gain and can lower the overall mechanical heating or cooling load. The enclosure components in a high-performance building like windows and doors are also thermally efficient to minimize heat loss or, if needed, heat gain.

The restriction of air movement by the air barrier system is one of the most important functions of the building enclosure. Air is a transport mechanism for water, vapour, heat energy, airborne contaminants, and even noise. Uncontrolled air leakage results in excessive heat loss that leads to discomfort and energy waste, and can lead to moisture issues within the building enclosure.

Besides improving the energy efficiency of the building, an enclosure-first approach can also contribute to better occupant comfort, since the building will allow less uncontrolled airflow and interior surfaces are warmer and a more uniform temperature (see [Thermal Comfort, Condensation and Hygiene on page 36](#)).

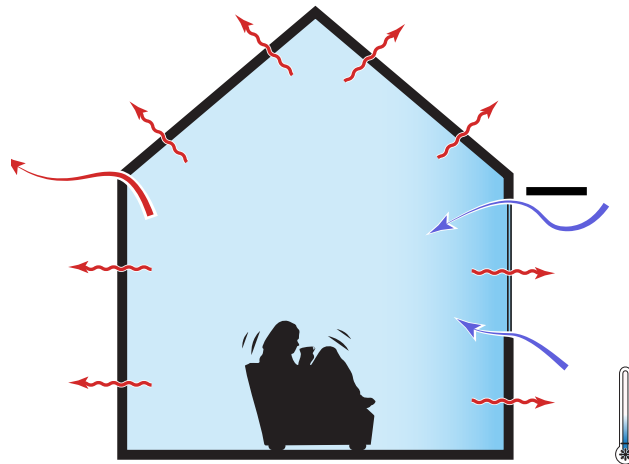

A building enclosure that is not thermally efficient and airtight will lead to excessive heating (and possibly cooling) loads.

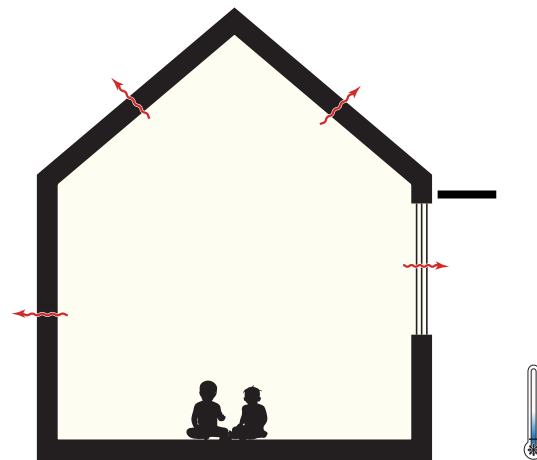

The enclosure-first approach in a high-performance building incorporates an airtight and thermally efficient building enclosure that allows thermal comfort in all seasons.



Building Components

Windows and Shading

Passive solar heating from solar radiation can be beneficial in the heating season if the building is oriented optimally. However, overheating in the summer can be a challenge if no measures are taken to limit solar heat gains during the non-heating season, especially late summer.

The solar angle (or elevation) varies seasonally, and is lower in the winter when passive solar heat gains are beneficial. The sun is higher in the sky in the summer when heat gains are detrimental. Building components like shading devices, overhangs, and vegetation can be used to limit solar radiation from the summer sun and allow solar radiation in the winter.

If no shading devices are used, glass with a low solar heat gain coefficient can serve to limit solar radiation. This approach to reducing summer heat gain also limits winter heat gain.

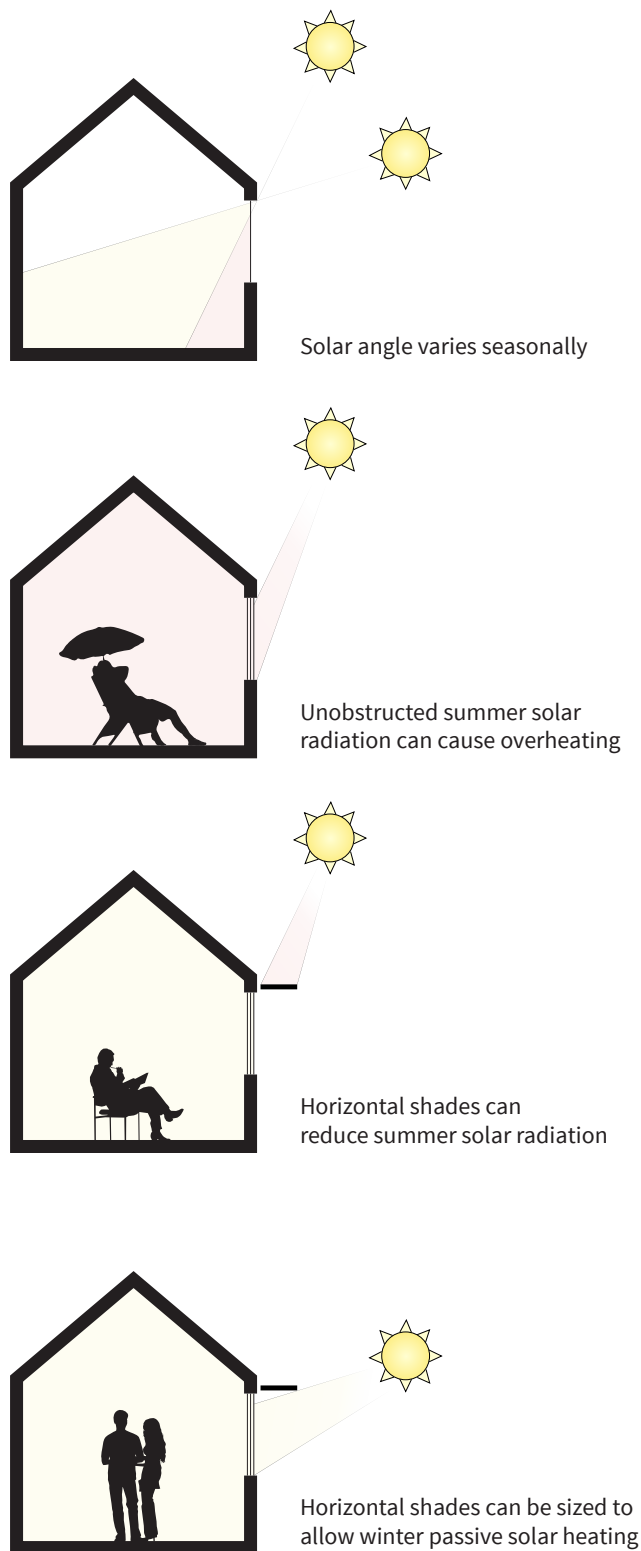

SHGC

The Solar Heat Gain Coefficient (SHGC) is the proportion of solar radiation transferred through the glass and framing of a product, and is a decimal fraction between 0.0 (totally opaque) and 1.0 (a hole in the wall). Higher SHGCs may help reach TEDI targets through passive gains, although care should be taken to minimize overheating. Builders should aim to optimize SHGC to help reach TEDI targets while using strategies such as exterior shading to maintain occupant thermal comfort.



Detailing

Continuity of the Air Barrier and Thermal Insulation

Careful consideration and attention to detail is required to ensure a continuous air barrier between assemblies, penetrations and building components. This is important as each is part of the air barrier system, which should provide a durable and continuous air barrier across the entire building enclosure.

The continuity of thermal insulation should also be considered while detailing. Conductive materials that penetrate the thermal insulation lead to heat loss, as well as potential durability issues. These thermal bridges should be avoided and/or reduced to a minimum.

While thermal bridging of building interfaces may not be directly accounted for in energy modelling software, it should be included as a reduction in the overall assembly R-value. For more guidance on accounting for assembly thermal bridging in energy models, refer to the City of Vancouver Energy Modelling Guidelines document (see [Additional Resources on page 147](#)), which is directly referenced in the Step Code.

See [Section 07 Airtightness on page 91](#) for more guidance on building airtightness and [Section 09 Details on page 115](#) for example details of typical important air barrier transition details for wood-frame buildings.

See also the *Illustrated Guide - Achieving Airtight Buildings* published by BC Housing (see [Additional Resources on page 147](#)).

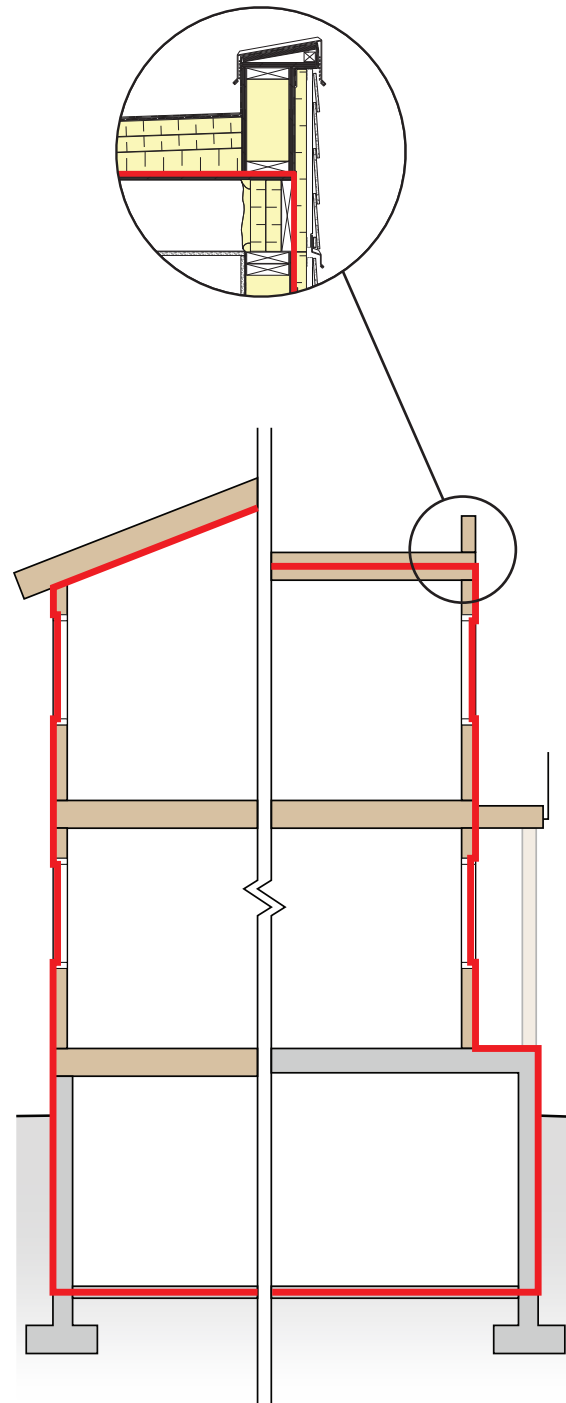

Building Enclosure Durability

While well-insulated enclosures are a key factor in reducing whole-building energy consumption, they can introduce risk factors with respect to durability if not carefully designed and constructed. Durability can be achieved by paying attention especially to moisture control (rain, airflow, and vapour flow).

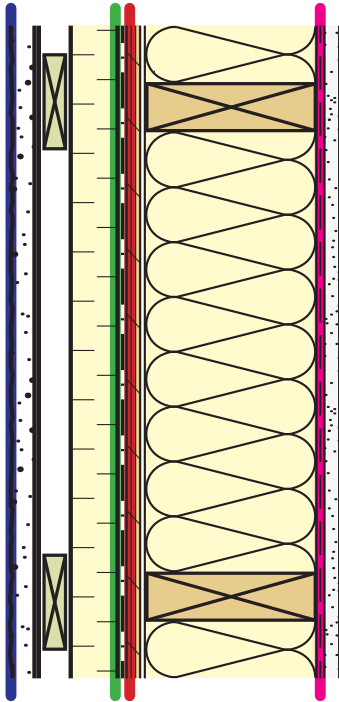

- Water shedding surface
- Water-resistive barrier
- Air barrier
- Thermal insulation
- Vapour retarder

1. Rain/Water Penetration

The basic principles of rain and water penetration control have been well understood for many years. The application of those principles in real buildings has been less than ideal far too often. Controlling exposure to rain and water is a two step process:

- Limit the amount of water that is able to come in contact with the building enclosure assemblies through the use of overhangs and drip edges.
- Use appropriate assemblies (e.g rainscreen walls) to control the water that does reach the building enclosure such that it does not penetrate through or into the enclosure to cause damage.

2. Airflow

Control of airflow is important to several aspects of building enclosure performance including:

- Pressure moderation as a part of water penetration control is highly dependent on the existence of an effective air barrier.
- An effective air barrier limits the amount of moisture that can be deposited within assemblies due to condensation.
- Unintentional airflow through the building enclosure can account for as much as 50% of the space heat loss.

3. Vapour Flow

While water penetration control is an important moisture control function, condensation moisture due to vapour flow can also lead to damage if not effectively controlled. Condensation involves changing water from the vapour form it takes when present in air, to a liquid form. It occurs on surfaces that are colder than the dew point temperature of the air they are exposed to. The variables that impact the potential for condensation include the temperature of surfaces, the air temperature, and the amount of vapour in the air (i.e. the dew point temperature). Controlling condensation can be achieved by:

- Minimizing vapour flow into/through assemblies by installing a vapour control layer such as a vapour retarder
- Reducing the amount of moisture in the indoor air
- Keeping surfaces warm, both interior surfaces and surfaces within building assemblies
- Controlling air movement into/through assemblies



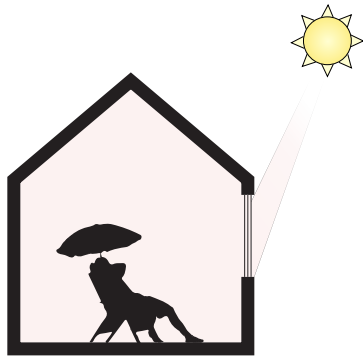

Unobstructed summer solar radiation can cause overheating.

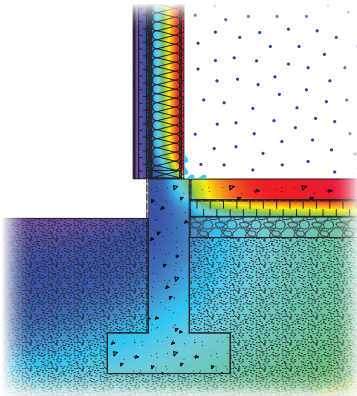

Excessive thermal bridging and ambient moisture can lead to condensation.

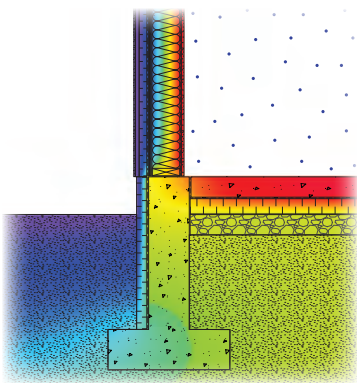

Correct enclosure configuration and adequate ventilation will reduce thermal bridging and ambient moisture levels.

Thermal Comfort, Condensation and Hygiene

Reducing space heating energy use is a primary function of the building enclosure. While heat flow through the building enclosure cannot be prevented, it can be controlled to reduce the total energy consumption and improve comfort due to higher and more even interior surface temperatures. This is achieved by constructing a thermally insulated and airtight building enclosure.

However, there are more factors influencing the thermal comfort, risk for condensation, and hygiene problems:

1. Overheating

Solar radiation delivers significant radiant heat energy to surfaces of the building enclosure. The glazing in windows can also allow a large portion of this energy to pass into the building. Heating of the enclosure and through the glazing can increase surface and ambient temperatures considerably and lead to the thermal comfort problems within the building. While this heat gain can help to offset heating loads in the building during cold seasons, it can also lead to overheating and increased cooling loads during warmer seasons. The control of solar radiation is a balance between these benefits and detriments. Energy modelling tools such those developed by NRCan and referenced by the CHBA Net Zero and R-2000 energy efficiency programs can be used to assess the risk of internal overheating of a building.

2. Thermal Bridging

Thermal bridging can result in cooler interior surfaces and greater potential for condensation and comfort issues, in addition to decreasing the effective R-value of the assembly. For example, exposed concrete at the foundation should be insulated to provide continuity, especially at the below-grade to above-grade transition.

3. Condensation

Regular excessive condensation at the building interior and interstitial surfaces (inside surface of exterior sheathing for example) due to high relative humidity or thermal bridging can also lead to fungal growth and decay. Avoiding condensation is an important part of building hygiene and occupant health and safety, as well as long-term durability.

4. Relative Humidity (RH)

In coastal climates, reducing the amount of moisture in the indoor air is a viable condensation control strategy during cold weather conditions. For example, it is quite possible for interior RH to reach 50% and above in a relatively airtight building with typical interior moisture generation sources. Ventilation can effectively dilute interior air with exterior air to bring the interior RH down to more comfortable levels and minimize condensation risk. In colder, drier climates, lack of ambient moisture may cause discomfort and may warrant a building humidification system, especially if forced-air heating is used.



05 Energy Performance Requirements

Section Includes:

- Climate Zones37
- Example Enclosure Performance Ranges39
- Mechanical Equipment Examples for Part 9 Buildings.46

Climate Zones

The BC Building Code defines the energy performance targets of the Step Code based on the building’s climate zone (CZ). The BC climate zones are defined by the average heating degree-days below 18° C (HDD). The BC Building Code states that the authority having jurisdiction (AHJ) can establish climatic values to define climate zones, typically based on information from Environment Canada, and building designers must consult the AHJ before making any assumptions about a building’s climate zone. Note that in some locations, there may be several climate zones due to variations in elevation.

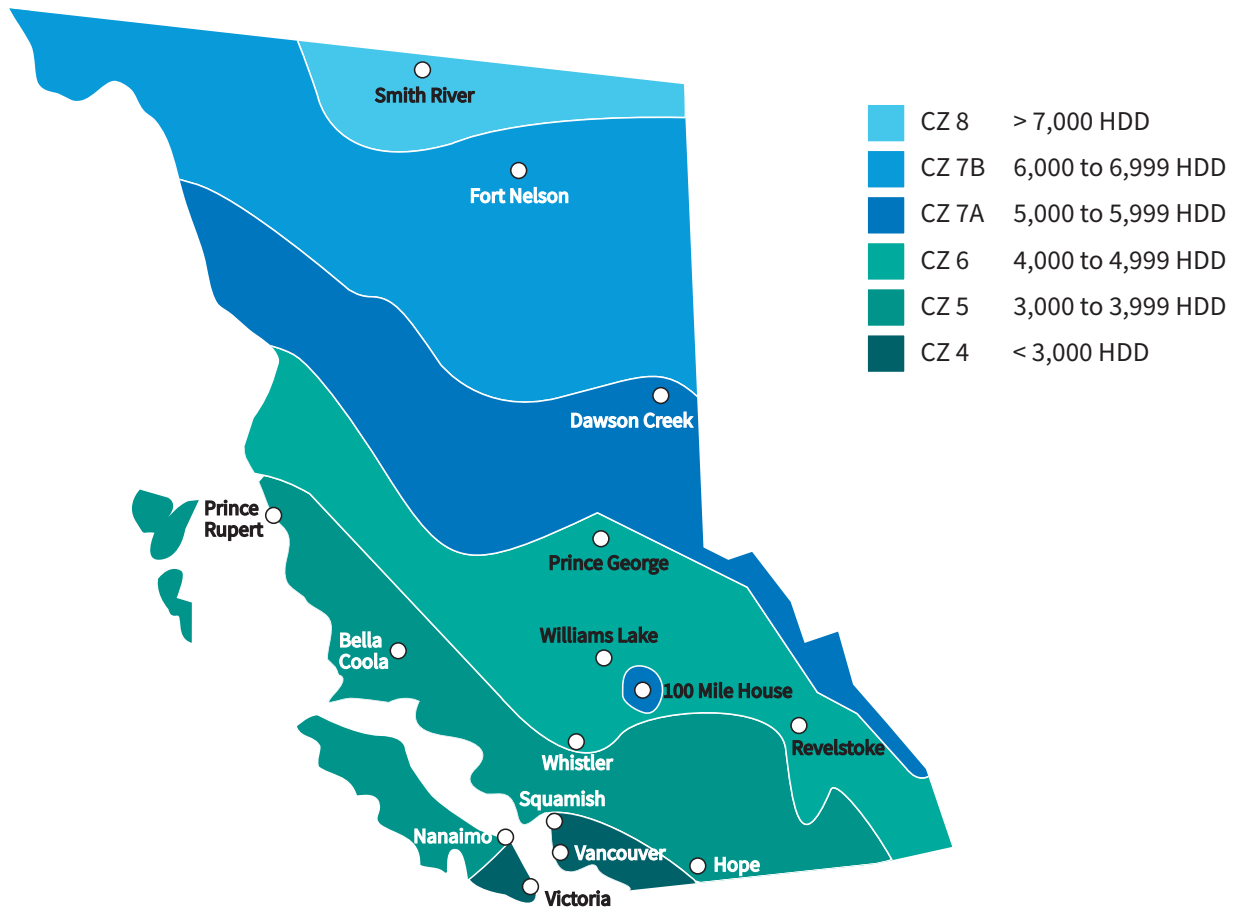

BC Climate Zone Per BCBC (* denotes locations with multiple climate zones)

CZ 4 < 3,000 HDD				
Abbotsford	Duncan	Langley	Richmond	Surrey
Agassiz	Delta	Mission	Sechelt	Vancouver
Burnaby*	Maple Ridge	New Westminster	Sidney	Victoria
Chilliwack	Jordan River	North Vancouver*	Sooke	West Vancouver
Crofton	Langford	Port Renfrew	Squamish	White Rock

CZ 5 3,000 to 3,999 HDD				
Alberni	Courtenay	Ladysmith	Osoyoos	Queen Charlotte City
Ashcroft	Crescent Valley	Lillooet	Parksville	Salmon Arm
Bamfield	Gold River	Lytton	Penticton	Sandspit
Bella Bella	Grand Forks	Masset	Port Alberni	Tahsis
Bella Coola	Hope	Merritt	Port Alice	Tofino
Burnaby (SFU)	Kamloops	Montrose	Port Hardy	Trail
Cache Creek	Kaslo	Nakusp	Port McNeill	Ucluelet
Campbell River	Kelowna	Nanaimo	Powell River	Vernon
Castlegar	Kitimat Plant	Nelson	Prince Rupert	Youbou
Comox	Kitimat Townsite	Ocean Falls	Qualicum Beach	

CZ 6 4,000 to 4,999 HDD				
Carmi	Fernie	McBride	Revelstoke	Williams Lake
Cranbrook	Golden	Prince George	Stewart	
Dog Creek	Greenwood	Princeton	Terrace	
Elko	Kimberley	Quesnel	Whistler	

CZ 7A 5,000 to 5,999 HDD	
100 Mile House	Glacier
Burns Lake	Mackenzie
Chetwynd	McLeod Lake
Dawson Creek	Smithers
Fort St. John	Taylor

CZ 7B 6,000 to 6,999 HDD
Beatton River
Dease Lake
Fort Nelson

CZ 8 > 7,000 HDD
Smith River

Note: Always confirm the climate zone of your project location with your local building official.





Enclosure Performance Ranges for Part 9 Buildings in Climate Zone 4

The graphic below outlines examples of building enclosure performance ranges which meet the Lower Steps in Climate Zone 4. The ranges are produced through energy modelling. Ranges for the Upper Steps will be presented in later editions of the Builder's Guide.



Note that a wide variety of enclosure assemblies may be used to comply with Step Code energy targets as long as performance targets are met.

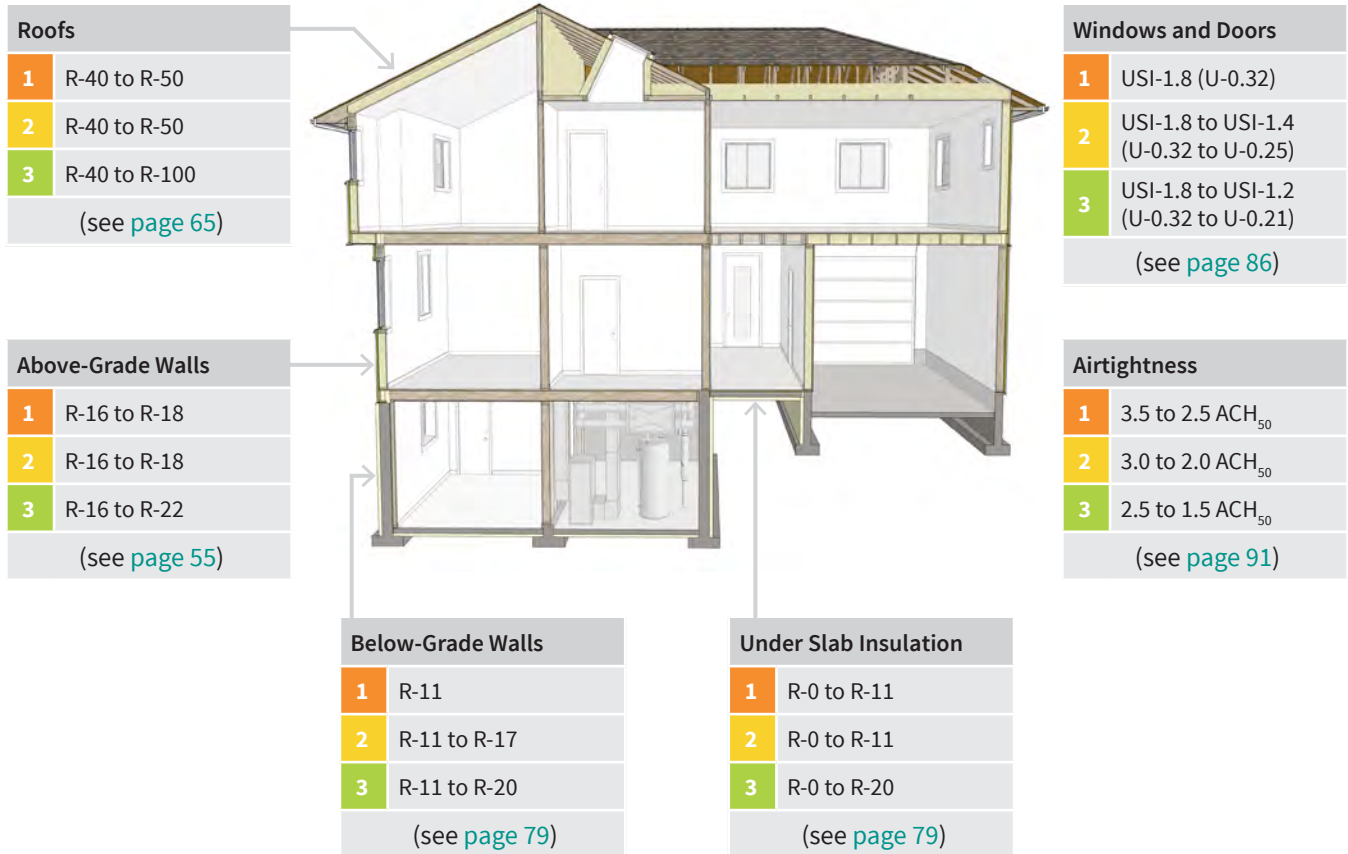

Metrics Research Report

The example performance ranges shown here are based on cost optimization of initial construction costs. R-values lower than current prescriptive code minimums are possible with the performance-based approach of the Step Code. For more information on the study of cost optimization for buildings aiming to meet the Step Code, refer to the *Energy Step Code 2018 Metrics Research Full Report* (Metrics Report, see [Additional Resources on page 147](#)).





Enclosure Performance Ranges for Part 9 Buildings in Climate Zone 5

The graphic below outlines examples of building enclosure performance ranges which meet the Lower Steps in Climate Zone 5. The ranges are produced through energy modelling. Ranges for the Upper Steps will be presented in later editions of the Builder's Guide.



Note that a wide variety of enclosure assemblies may be used to comply with Step Code energy targets as long as performance targets are met.

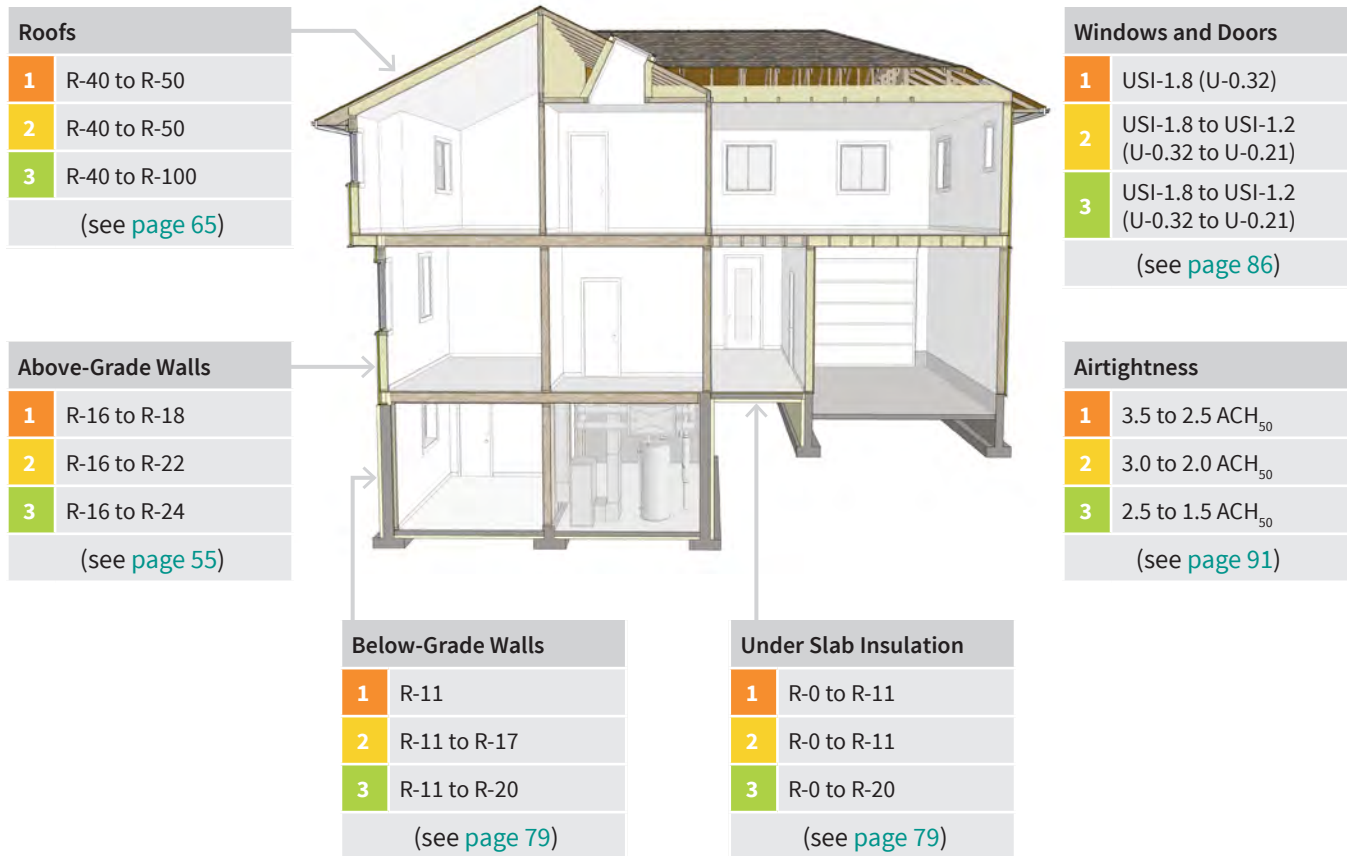

Metrics Research Report

The example performance ranges shown here are based on cost optimization of initial construction costs. R-values lower than current prescriptive code minimums are possible with the performance-based approach of the Step Code. For more information on the study of cost optimization for buildings aiming to meet the Step Code, refer to the *Energy Step Code 2018 Metrics Research Full Report* (see [Additional Resources on page 147](#)).





Enclosure Performance Ranges for Part 9 Buildings in Climate Zone 6

The graphic below outlines examples of building enclosure performance ranges which meet the Lower Steps in Climate Zone 6. The ranges are produced through energy modelling. Ranges for the Upper Steps will be presented in later editions of the Builder's Guide.

Note that a wide variety of enclosure assemblies may be used to comply with Step Code energy targets as long as performance targets are met.

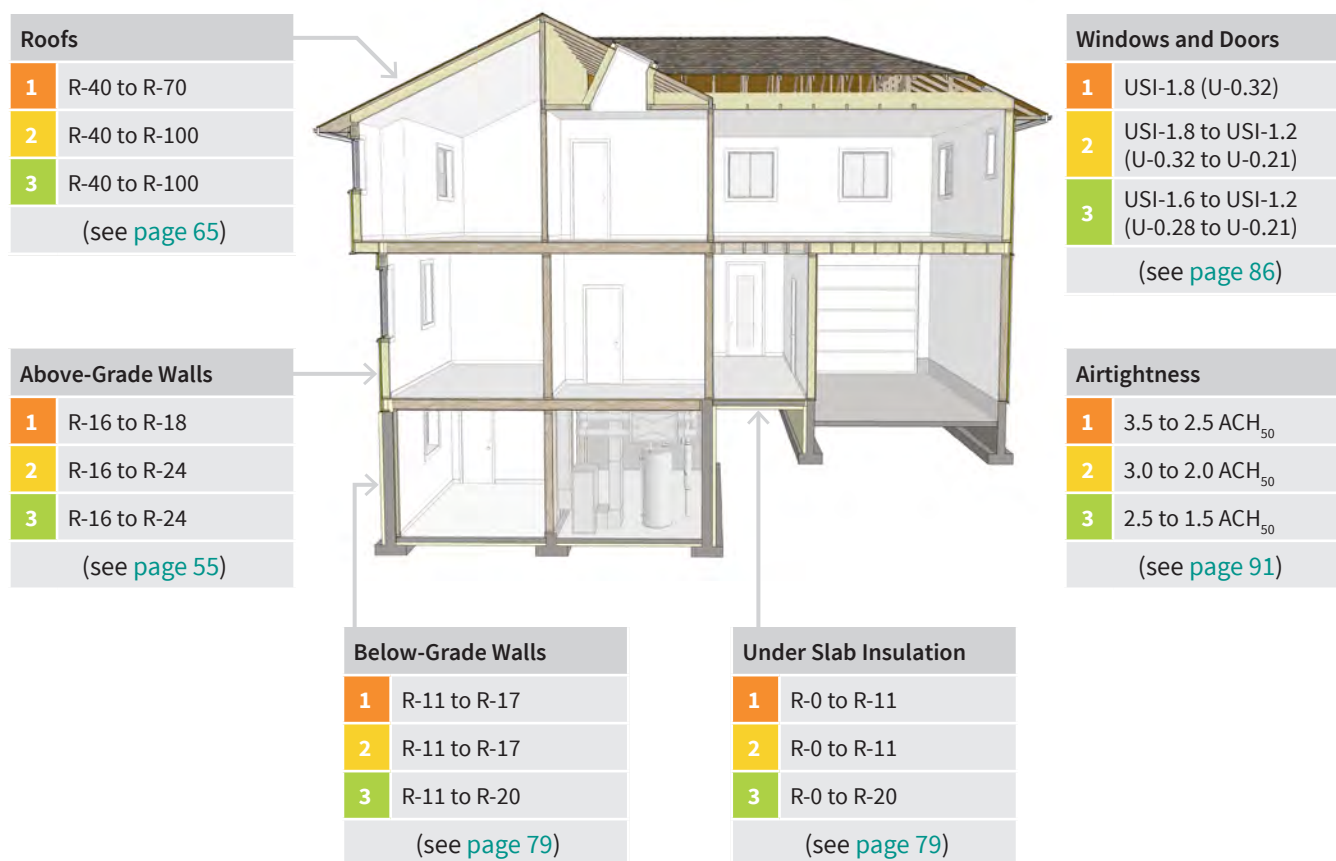

Metrics Research Report

The example performance ranges shown here are based on cost optimization of initial construction costs. R-values lower than current prescriptive code minimums are possible with the performance-based approach of the Step Code. For more information on the study of cost optimization for buildings aiming to meet the Step Code, refer to the *Energy Step Code 2018 Metrics Research Full Report* (see [Additional Resources on page 147](#)).





Enclosure Performance Ranges for Part 9 Buildings in Climate Zone 7A

The graphic below outlines examples of building enclosure performance ranges which meet the Lower Steps in Climate Zone 7A. The ranges are produced through energy modelling. Ranges for the Upper Steps will be presented in later editions of the Builder's Guide.



Note that a wide variety of enclosure assemblies may be used to comply with Step Code energy targets as long as performance targets are met.

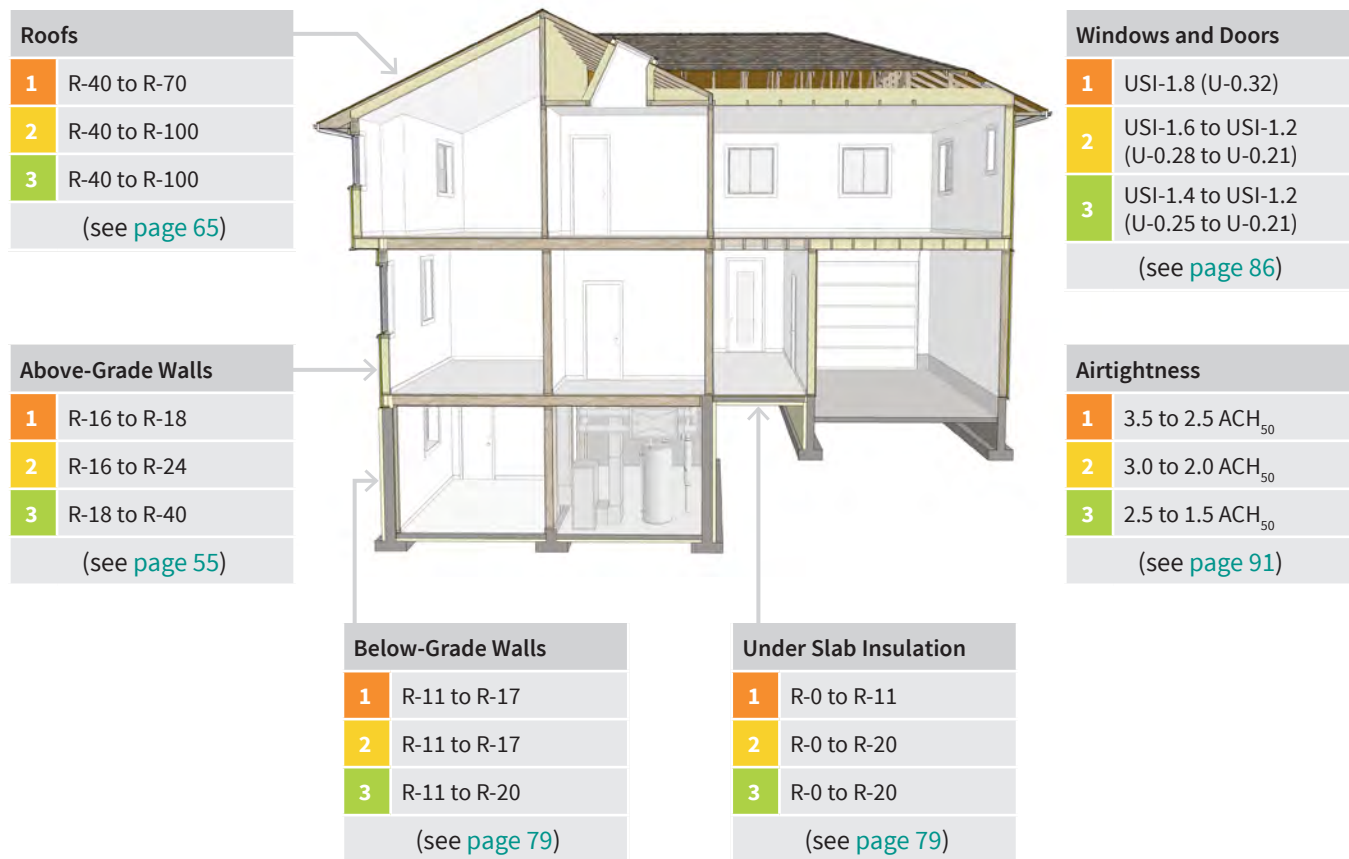

Metrics Research Report

The example performance ranges shown here are based on cost optimization of initial construction costs. R-values lower than current prescriptive code minimums are possible with the performance-based approach of the Step Code. For more information on the study of cost optimization for buildings aiming to meet the Step Code, refer to the *Energy Step Code 2018 Metrics Research Full Report* (see [Additional Resources on page 147](#)).





Enclosure Performance Ranges for Part 9 Buildings in Climate Zone 7B



The graphic below outlines examples of building enclosure performance ranges which meet the Lower Steps in Climate Zone 7B. The ranges are produced through energy modelling. Ranges for the Upper Steps will be presented in later editions of the Builder's Guide.

Note that a wide variety of enclosure assemblies may be used to comply with Step Code energy targets as long as performance targets are met.

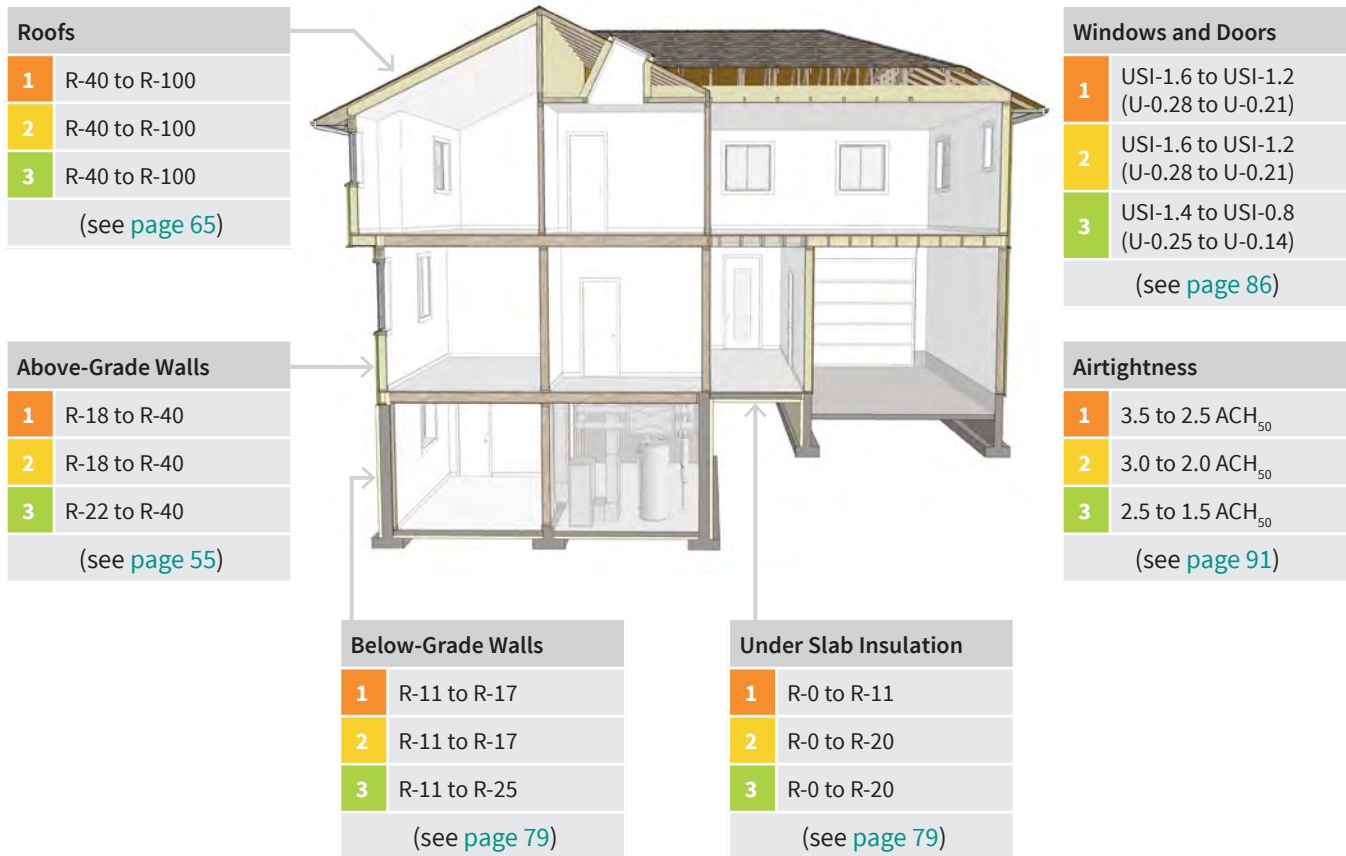

Metrics Research Report

The example performance ranges shown here are based on cost optimization of initial construction costs. R-values lower than current prescriptive code minimums are possible with the performance-based approach of the Step Code. For more information on the study of cost optimization for buildings aiming to meet the Step Code, refer to the *Energy Step Code 2018 Metrics Research Full Report* (see [Additional Resources on page 147](#)).





Enclosure Performance Ranges for Part 9 Buildings in Climate Zone 8



The graphic below outlines examples of building enclosure performance ranges which meet the Lower Steps in Climate Zone 8. The ranges are produced through energy modelling. Ranges for the Upper Steps will be presented in later editions of the Builder's Guide.

Note that a wide variety of enclosure assemblies may be used to comply with Step Code energy targets as long as performance targets are met.

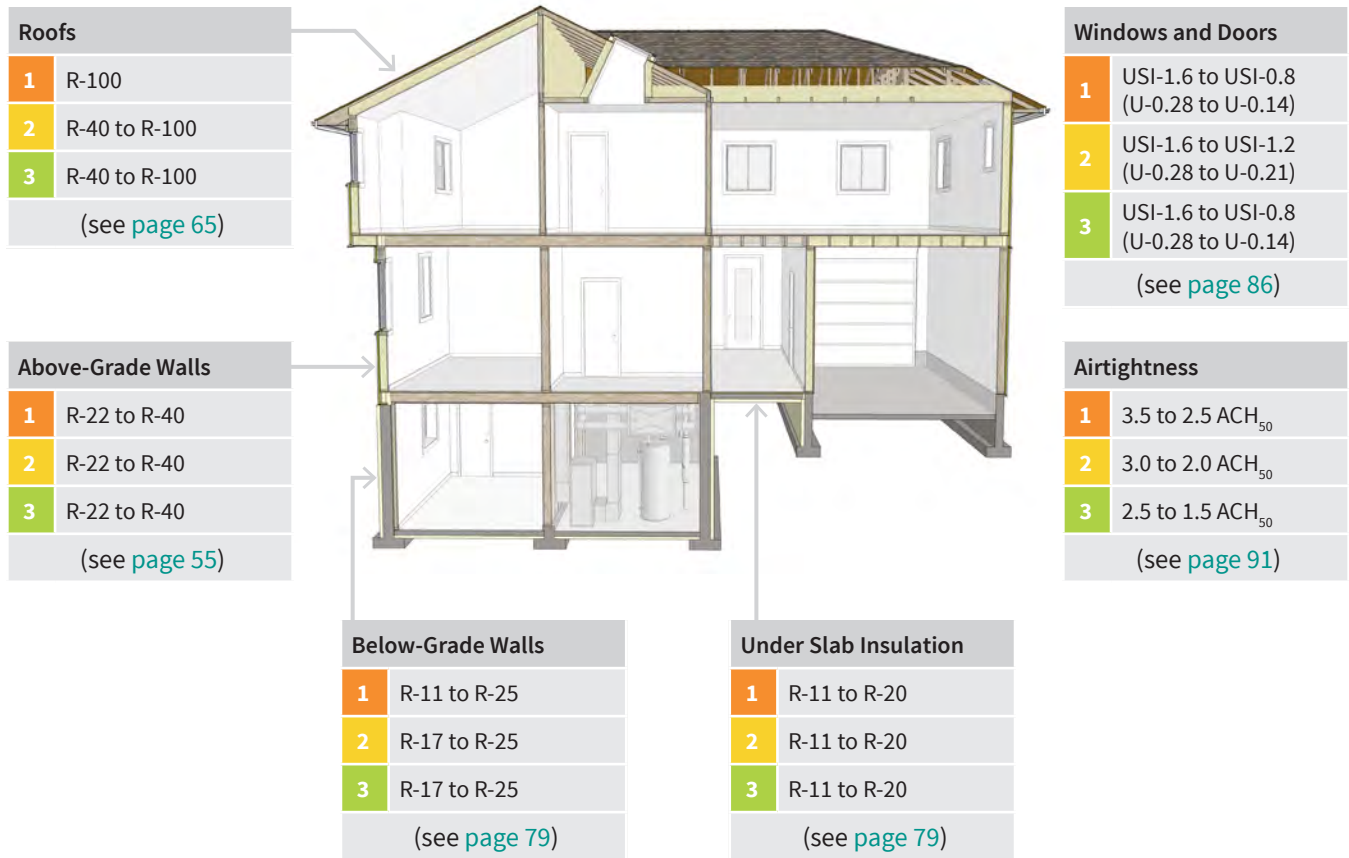

Metrics Research Report

The example performance ranges shown here are based on cost optimization of initial construction costs. R-values lower than current prescriptive code minimums are possible with the performance-based approach of the Step Code. For more information on the study of cost optimization for buildings aiming to meet the Step Code, refer to the *Energy Step Code 2018 Metrics Research Full Report* (see [Additional Resources on page 147](#)).





Enclosure Performance Ranges for Part 3 Buildings in Climate Zone 4

The graphic below outlines examples of building enclosure performance ranges which meet the Lower Steps in Climate Zone 4. The ranges are produced through energy modelling. Ranges for the Upper Steps will be presented in later editions of the Builder’s Guide.

Note that a wide variety of enclosure assemblies may be used to comply with Step Code energy targets as long as performance targets are met. Enclosure consultants should be retained when selecting assemblies for Part 3 buildings.

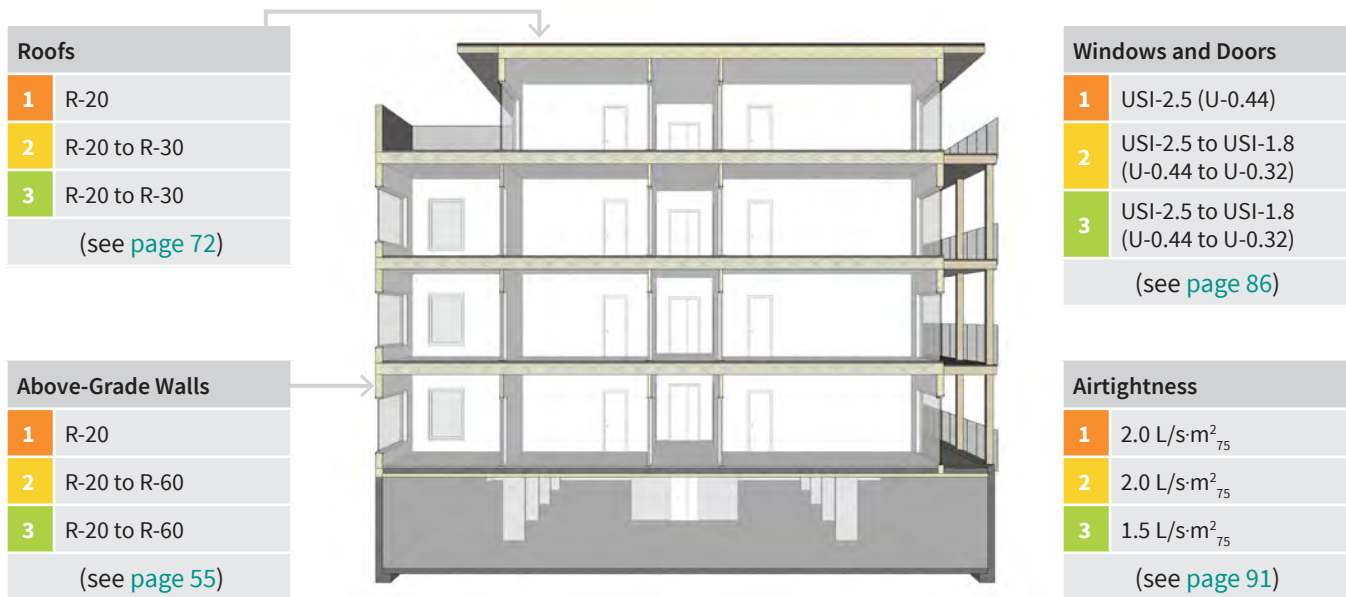

Metrics Research Report

The example performance ranges shown here are based on cost optimization of initial construction costs. R-values lower than current prescriptive code minimums are possible with the performance-based approach of the Step Code. For more information on the study of cost optimization for buildings aiming to meet the Step Code, refer to the *Energy Step Code 2018 Metrics Research Full Report* (see [Additional Resources on page 147](#)).



Mechanical Equipment Examples for Part 9 Buildings

Part 3 Mechanical Systems

A wide range of mechanical systems may be used to comply with Step Code energy targets. A selection of mechanical equipment options are shown for guidance (see [Section 08 Mechanical Equipment and Systems on page 107](#)), however there are many other systems which may be chosen. Mechanical designers should be consulted when selecting systems for Part 3 buildings.

The tables in this section show some common mechanical equipment likely to be used in Part 9 buildings aiming to meet the Step Code. The likeliness of each system type and efficiency level is given based on cost optimization for each step of the Step Code adapted from modelling work in the Metrics Study. The analysis used small, medium, and large single-family home archetypes. This section is not intended to restrict the use of any mechanical system or specific product. Part 9 buildings may use a wide variety of options, as long as the systems are modelled for compliance with Step Code metric targets.

Further information on various common mechanical equipment likely to be used in Part 9 buildings is included in [Section 08 Mechanical Equipment and Systems on page 107](#) of this guide. Section 08 also includes mechanical equipment for Part 3 buildings.



Operating Costs

While the examples in this section are based on cost optimization for lowest incremental capital cost, selection of mechanical equipment based on reduced operating costs for the end user may be worth considering. This cost optimization approach is referred to as net present value (NPV). For more information on the study of cost optimization for buildings aiming to meet the Step Code, refer to the *Energy Step Code 2018 Metrics Research Full Report* (see [Additional Resources on page 147](#)).





Mechanical Equipment Examples for Part 9 Single Family Homes in Climate Zone 4



The table below shows the relative likelihood of usage of common mechanical equipment in Part 9 single family homes to meet the Step Code in Climate Zone 4. The information was generated based on modelling work adapted from the Metrics Study, optimized for lowest incremental capital cost (ICC) as a financial metric. This section is not intended to restrict the use of any mechanical system or specific product. Part 9 buildings may use a wide variety of options, as long as the systems are modelled for compliance with Step Code metric targets.

Heating System (see page 109)				
	Gas furnace 92% AFUE	Gas furnace 96% AFUE	Electric baseboard	Air source heat pump
STEP 1	[Progress bar]		[Progress bar]	[Progress bar]
STEP 2	[Progress bar]	[Progress bar]	[Progress bar]	[Progress bar]
STEP 3	[Progress bar]	[Progress bar]	[Progress bar]	[Progress bar]

Heat Recovery Ventilators (see page 111)				
	No HRV	60% efficiency	70% efficiency	Above 70% efficiency
STEP 1	[Progress bar]	[Progress bar]	[Progress bar]	[Progress bar]
STEP 2	[Progress bar]	[Progress bar]	[Progress bar]	[Progress bar]
STEP 3	[Progress bar]	[Progress bar]	[Progress bar]	[Progress bar]

Domestic Hot Water (see page 113)				
	Gas storage	Electric storage	On-demand gas	Air source heat pump
STEP 1	[Progress bar]	[Progress bar]	[Progress bar]	[Progress bar]
STEP 2	[Progress bar]	[Progress bar]	[Progress bar]	[Progress bar]
STEP 3	[Progress bar]	[Progress bar]	[Progress bar]	[Progress bar]

Drain Water Heat Recovery (see page 113)				
	No DWHR	30% efficiency	42% efficiency	55% efficiency
STEP 1	[Progress bar]	[Progress bar]	[Progress bar]	[Progress bar]
STEP 2	[Progress bar]	[Progress bar]	[Progress bar]	[Progress bar]
STEP 3	[Progress bar]	[Progress bar]	[Progress bar]	[Progress bar]





Mechanical Equipment Examples for Part 9 Single Family Homes in Climate Zone 5



The table below shows the relative likelihood of usage of common mechanical equipment in Part 9 single family homes to meet the Step Code in Climate Zone 5. The information was generated based on modelling work adapted from the Metrics Study, optimized for lowest incremental capital cost (ICC) as a financial metric. This section is not intended to restrict the use of any mechanical system or specific product. Part 9 buildings may use a wide variety of options, as long as the systems are modelled for compliance with Step Code metric targets.

Heating System (see page 109)				
	Gas furnace 92% AFUE	Gas furnace 96% AFUE	Electric baseboard	Air source heat pump
STEP 1				
STEP 2				
STEP 3				

Heat Recovery Ventilators (see page 111)				
	No HRV	60% efficiency	70% efficiency	Above 70% efficiency
STEP 1				
STEP 2				
STEP 3				

Domestic Hot Water (see page 113)				
	Gas storage	Electric storage	On-demand gas	Air source heat pump
STEP 1				
STEP 2				
STEP 3				

Drain Water Heat Recovery (see page 113)				
	No DWHR	30% efficiency	42% efficiency	55% efficiency
STEP 1				
STEP 2				
STEP 3				





Mechanical Equipment Examples for Part 9 Single Family Homes in Climate Zone 6



The table below shows the relative likelihood of usage of common mechanical equipment in Part 9 single family homes to meet the Step Code in Climate Zone 6. The information was generated based on modelling work adapted from the Metrics Study, optimized for lowest incremental capital cost (ICC) as a financial metric. This section is not intended to restrict the use of any mechanical system or specific product. Part 9 buildings may use a wide variety of options, as long as the systems are modelled for compliance with Step Code metric targets.

Heating System (see page 109)				
	Gas furnace 92% AFUE	Gas furnace 96% AFUE	Electric baseboard	Air source heat pump
STEP 1				
STEP 2				
STEP 3				

Heat Recovery Ventilators (see page 111)				
	No HRV	60% efficiency	70% efficiency	Above 70% efficiency
STEP 1				
STEP 2				
STEP 3				

Domestic Hot Water (see page 113)				
	Gas storage	Electric storage	On-demand gas	Air source heat pump
STEP 1				
STEP 2				
STEP 3				

Drain Water Heat Recovery (see page 113)				
	No DWHR	30% efficiency	42% efficiency	55% efficiency
STEP 1				
STEP 2				
STEP 3				





Mechanical Equipment Examples for Part 9 Single Family Homes in Climate Zone 7A



The table below shows the relative likelihood of usage of common mechanical equipment in Part 9 single family homes to meet the Step Code in Climate Zone 7A. The information was generated based on modelling work adapted from the Metrics Study, optimized for lowest incremental capital cost (ICC) as a financial metric. This section is not intended to restrict the use of any mechanical system or specific product. Part 9 buildings may use a wide variety of options, as long as the systems are modelled for compliance with Step Code metric targets.

Heating System (see page 109)				
	Gas furnace 92% AFUE	Gas furnace 96% AFUE	Electric baseboard	Air source heat pump
STEP 1	Low	Low	High	High
STEP 2	High	Low	High	Low
STEP 3	High	High	High	Low

Heat Recovery Ventilators (see page 111)				
	No HRV	60% efficiency	70% efficiency	Above 70% efficiency
STEP 1	High	Low	High	High
STEP 2	High	High	High	High
STEP 3	High	High	High	High

Domestic Hot Water (see page 113)				
	Gas storage	Electric storage	On-demand gas	Air source heat pump
STEP 1	High	Low	High	High
STEP 2	High	High	High	High
STEP 3	High	High	High	High

Drain Water Heat Recovery (see page 113)				
	No DWHR	30% efficiency	42% efficiency	55% efficiency
STEP 1	High	Low	High	High
STEP 2	High	High	High	High
STEP 3	High	High	High	High



06 Assemblies

Section Includes:

- Overview 54
- Above-Grade Walls 55
 - Stud-Insulated Wall Assembly 56
 - Split-Insulated Wall with Thin Exterior Insulation 58
 - Split-Insulated Wall with Thick Exterior Insulation 60
 - Deep Stud-Insulated Wall with Service Cavity 62
 - Other Wall Types 64
- Sloped Roof Assemblies 65
 - Insulated Attic Sloped Roof 66
 - Joist-Insulated Sloped Roof 68
 - Exterior-Insulated Sloped Roof 70
- Low-Slope Roof Assemblies 72
 - Joist-Insulated Vented Roof 73
 - Exterior-Insulated Conventional Roof 75
 - Exterior-Insulated Inverted (Protected Membrane) Roof 77
 - Split-Insulated Roof 78
- Below-Grade Walls and Slab 79
 - Exterior-Insulated Concrete Wall 80
 - Interior-Insulated Concrete Wall 81
 - Insulating Concrete Forms (ICF) Wall 82
 - Exterior-Insulated Concrete Slab 84
- Windows and Doors 86
 - Energy Performance of Windows and Doors 87
 - Insulating Glazing Unit Components 88



Overview

Framing Factors

For all effective R-values provided in this guide, unless otherwise noted, the calculations use a framing factor corresponding with standard framing practices for 16" spaced members, according to Table A-9.36.s.4.(1)A.

In larger buildings, framing factors can be 30% or higher in some areas. More accurate framing factors for assemblies can be determined based on the structural requirements of the building, and should include stud packs, built-up beams, and framing for seismic components.

This section outlines the key design and construction considerations for various assembly types that are likely to be used in buildings intending to meet Step Code.

Effective Thermal Resistance

The thermal resistance of opaque building assemblies is indicated using imperial effective R-value [$\text{ft}^2 \cdot \text{hr} / \text{Btu}$] or metric RSI-value [$\text{m}^2 \cdot \text{K} / \text{W}$]. All R-values in this guide are provided in imperial units. The higher the R-value, the better the thermal performance.

$$\text{RSI } 1.0 [\text{m}^2 \cdot \text{K} / \text{W}] = \text{R-5.678} [\text{ft}^2 \cdot \text{hr} / \text{Btu}]$$

The effective R-value of most standard wood-frame assemblies can be calculated using the Isothermal Planes method, where the R-value of each layer is added together. The R-value of assemblies which include multiple paths of heat flow, such as insulated stud walls, should be calculated using the Parallel Paths method. Both methods are described in detail in Section 9.36.2 of the BC Building Code. Refer to the documents listed in [Additional Resources on page 147](#) for more information on calculating the effective R-value of building enclosure assemblies. The Step Code energy performance requirements do not specify the required assembly effective thermal performance, so the assemblies included in this section include a range of thermal performance values that may be used across the various steps.

Example Effective Thermal Resistance Calculation for a Split-Insulated Wall Assembly

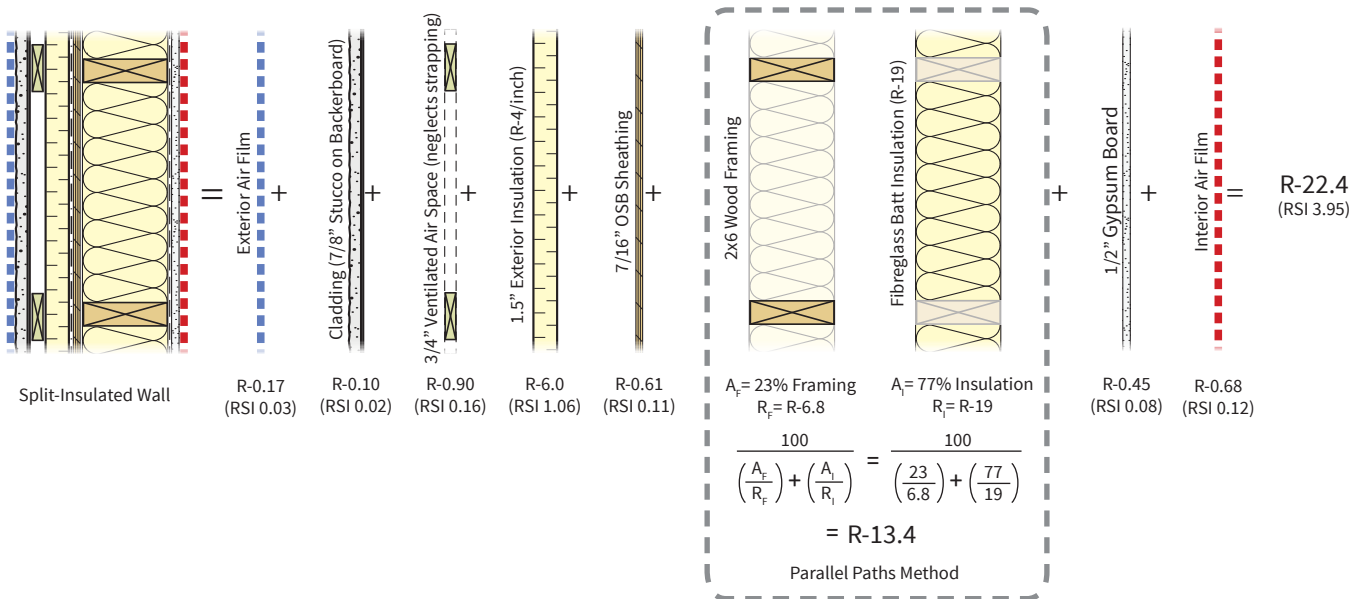

Above-Grade Walls

This section provides information about four different above-grade wood-frame wall assemblies that can be used to achieve various thermal performance targets. The below graph shows the potential effective R-value ranges for each wall type. Refer to the specific assembly section for more information. See also the *Illustrated Guide - R22+ Effective Walls in Residential Construction in British Columbia* for more information (see [Additional Resources on page 147](#)).

R-value Ranges for Wall Assemblies Covered in This Guide

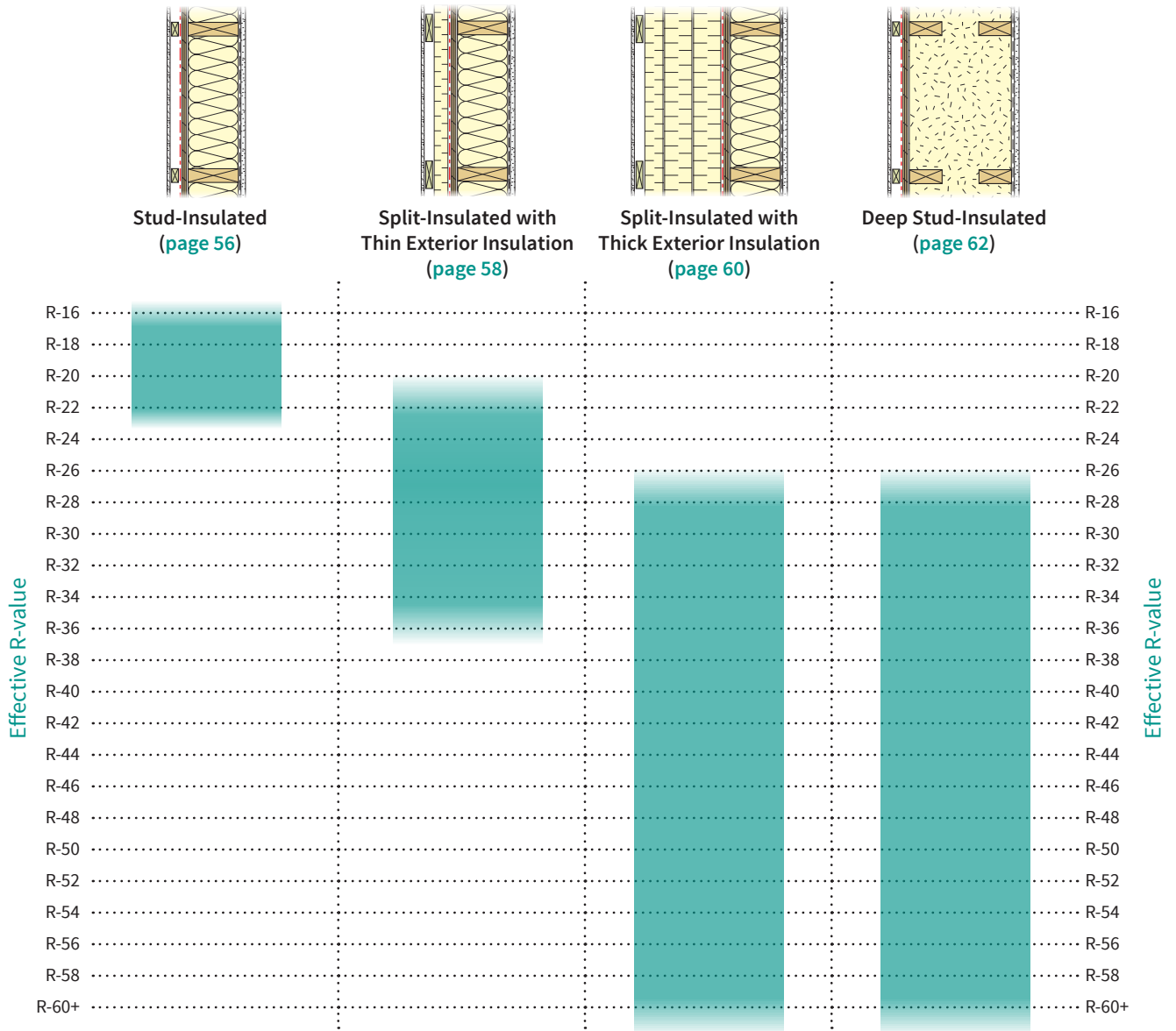

Stud-Insulated Wall Assembly

This above-grade wall assembly consists of an insulated 2x6 or 2x8 wood-frame wall. Effective R-values of the assembly are achieved by using insulation in the stud space.

Air Barrier

This assembly can accommodate several air barrier strategies. However, often the most straightforward one to use is the exterior sheathing membrane. If the sheathing membrane is to form the air barrier, it must be taped and sealed to ensure continuity. Structural support of the sheathing membrane is provided by the strapping and sheathing on either side. Alternatively, a sealed sheathing approach can be used, or potentially an airtight drywall approach or airtight polyethylene, though ensuring continuity of the latter approaches can be difficult. Continuity of the air barrier at transitions and penetrations is critical to its performance. See [Section 07 Airtightness on page 91](#) for further guidance.

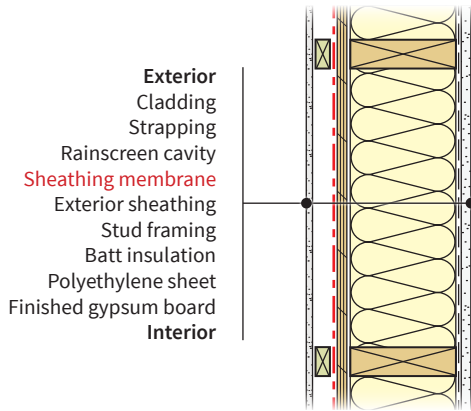

Insulation

The stud space can be insulated using a variety of different insulation types, including batts (i.e. mineral wool or fibreglass), blown-in fibrous insulation (i.e. cellulose or fibreglass), or spray foam. The effective R-value of the stud-insulated wall is somewhat limited by the thermal bridging through wood framing members. In larger buildings with higher framing factors the R-value is further reduced.

Effective R-values | Stud-Insulated Wall

		R-value/inch of Stud Insulation			
		R-3.4	R-4.0	R-5.0	R-6.0
Wall Framing	2x6	16.2	17.3	18.9	20.2
	2x8	20.4	21.8	24.0	25.7

A 23% framing factor is assumed which is consistent with standard 16" o.c. framing practices in Part 9 construction.



Stud-Insulated Wall Assembly Details Wayfinder

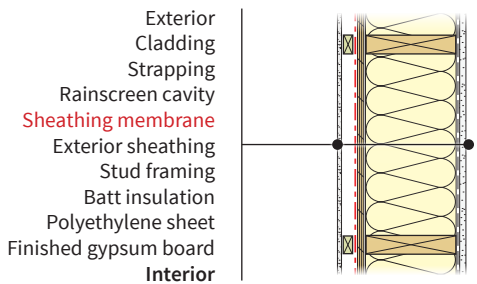
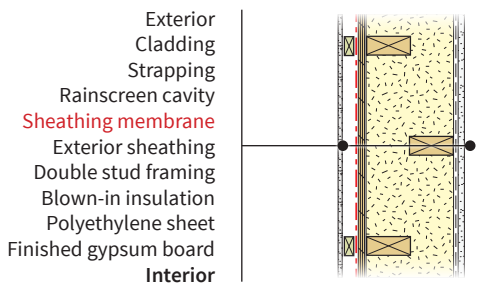
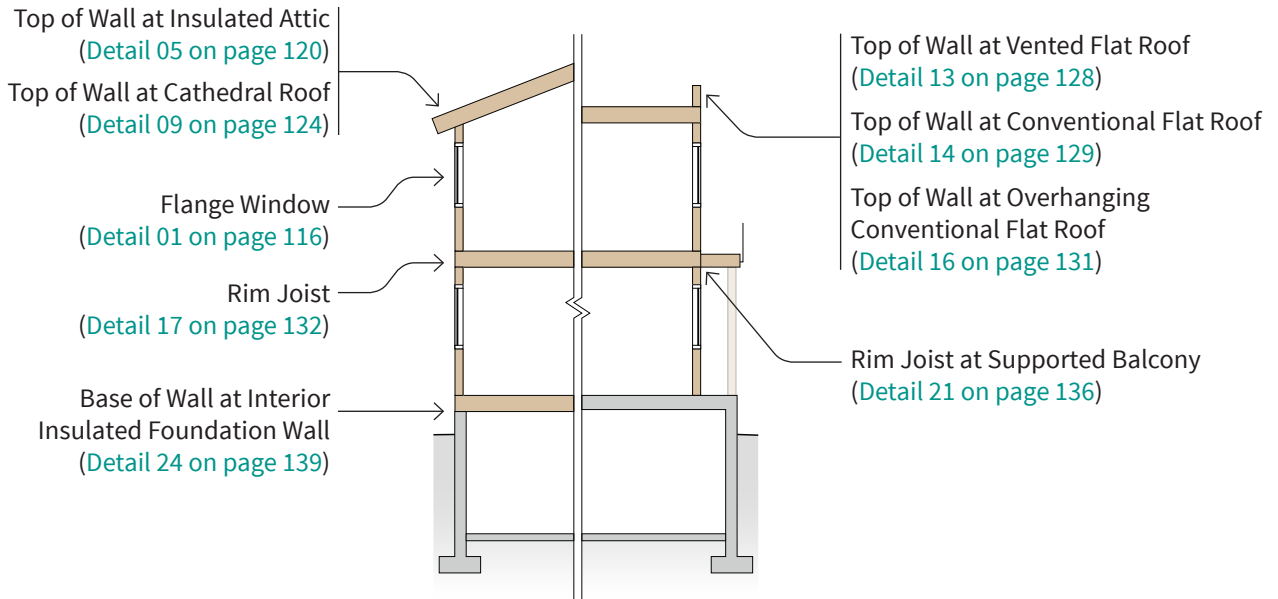

Other Arrangements

Other framing arrangements include double studs and offset double studs, and deeper stud framing up to 2x10 members. In double stud walls, the reduced amount of framing and the gap between framing members can improve the wall effective R-value compared to standard framing. Deeper wall assemblies with standard framing provide some improvement to the effective R-value, though the increased depth using standard framing has diminishing returns. Refer to the *Illustrated Guide - R22+ Effective Walls in Residential Construction in British Columbia* for more information on double stud and deeper stud-insulated wall assemblies (see [Additional Resources on page 147](#)).



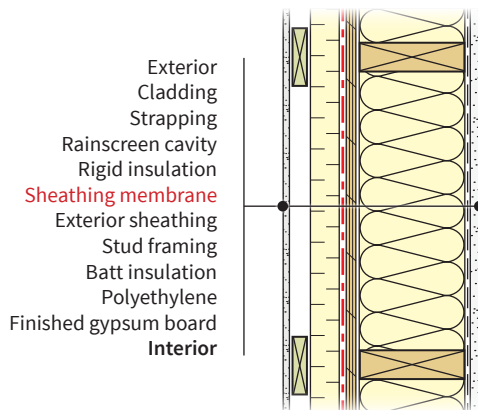

Key Considerations

The method of cladding attachment is important to limit thermal bridging through the exterior insulation while adequately supporting the exterior cladding.

The vapour permeability of the sheathing membrane and exterior insulation should be carefully considered so as not to create a risk of condensation within the assembly, or to reduce the ability of the assembly to dry in the event that incidental wetting occurs. In BC's climate zones, a vapour permeable exterior insulation in combination with an interior vapour barrier typically provides a lower risk wall assembly than does an assembly using impermeable exterior insulation.

Split-Insulated Wall with Thin Exterior Insulation

This above-grade wall assembly consists of rigid or semi-rigid insulation placed on the exterior of a conventional above-grade insulated wood-frame wall assembly. High effective R-values are achieved by using continuous insulation outside of the structural framing and low-conductivity cladding attachments, in combination with insulation in the stud space. In most cases, cladding can be supported by strapping fastened with screws through rigid insulation. It is also possible to use low-conductivity cladding attachment systems. The exterior insulation product used in this arrangement should not be sensitive to moisture as it will be exposed to periodic wetting. In cold climates, insulation placed on the exterior of the stud wall increases the temperature of the moisture-sensitive wood sheathing and framing and consequently often improves the durability of the assembly by reducing the risk of condensation and associated moisture damage.

Air Barrier

This assembly can accommodate several air barrier strategies. However, often the most straightforward one to use is the exterior sheathing membrane. If the sheathing membrane is to form the air barrier, it must be taped and sealed to ensure continuity. Structural support of the sheathing membrane is provided by the insulation and sheathing on either side of it. Alternatively, a sealed sheathing approach can be used, or potentially an airtight drywall approach or airtight polyethylene, though ensuring continuity of the latter approaches can be arduous. Continuity of the air barrier at transitions and penetrations is critical to its performance. See for further guidance.

Insulation

The stud space can be insulated using a variety of different insulation types, including batts (i.e. mineral wool or fiberglass), blown-in fibrous insulation (i.e. cellulose or fiberglass), or spray foam.

Various types of exterior insulation can potentially be used in split insulation wall assemblies, including permeable insulations such as semi-rigid or rigid mineral wool, or semi-rigid fiberglass, and relatively impermeable insulations such as extruded polystyrene (XPS), expanded polystyrene (EPS), polyisocyanurate (polyiso), and closed-cell spray polyurethane foam. While each of these insulation materials can provide adequate thermal resistance, the permeability of the materials is of particular importance with respect to the drying capacity of the wall assembly. In general, vapour permeable exterior insulation typically provides a lower risk than impermeable exterior insulation.



Effective R-values | Split-Insulated Wall with Thin Exterior Insulation

	2x4 Framed Wall (R-12 Batts)		2x6 Framed Wall (R-19 Batts)		
	R-value/inch of Exterior Insulation		R-value/inch of Exterior Insulation		
	R-4 / inch	R-5 / inch	R-4 / inch	R-5 / inch	
0.0	11.3	11.3	16.2	16.2	0.0
0.5	13.3	13.8	18.2	18.7	0.5
1.0	15.3	16.3	20.2	21.2	1.0
1.5	17.3	18.8	22.2	23.7	1.5
2.0	19.3	21.3	24.2	26.2	2.0
2.5	21.3	23.8	26.2	28.7	2.5
3.0	23.3	26.3	28.2	31.2	3.0
3.5	25.3	28.8	30.2	33.7	3.5
4.0	27.3	31.3	32.2	36.2	4.0

A 23% framing factor is assumed which is consistent with standard 16" o.c. stud framing practices in Part 9 construction.

Thermal bridging through exterior insulation is not accounted for but may be worth considering depending on the attachment strategy used. Refer to the *Illustrated Guide - R22+ Effective Walls in Residential Construction in British Columbia* for more information.

Split-Insulated Wall Assembly Details Wayfinder

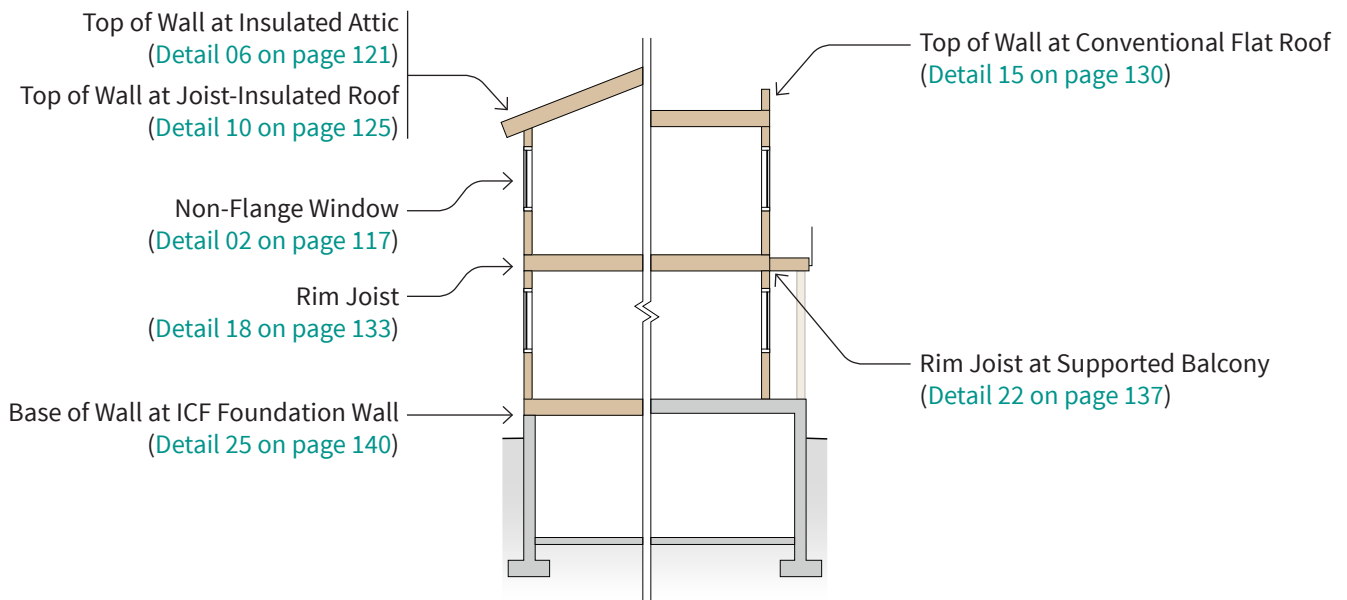

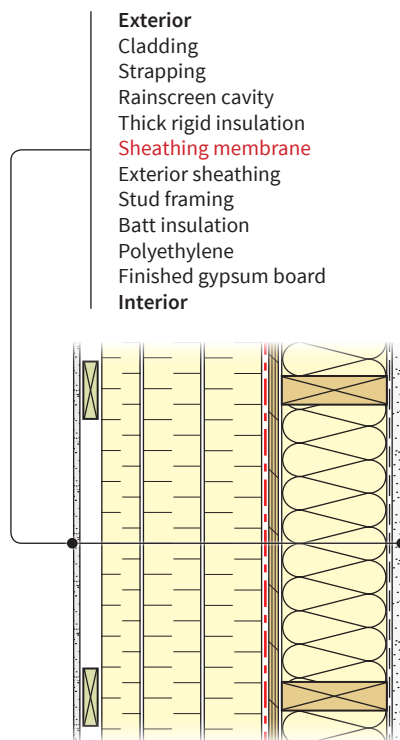

Split-Insulated Wall with Thick Exterior Insulation

This above-grade wall assembly consists of multiple layers of rigid or semi-rigid insulation placed on the exterior of a conventional above-grade insulated wood-frame wall assembly. High effective R-values of the assembly are achieved by using thick continuous insulation outside of the structural framing and low-conductivity cladding attachments, in combination with insulation in the stud space. In most cases, cladding can be supported by strapping fastened with screws through rigid insulation. It is also possible to use low-conductivity cladding attachment systems. Where possible, the thermal bridging through the exterior insulation by the attachment components should be considered. The exterior insulation product used in this arrangement should not be sensitive to moisture as it will be exposed to periodic wetting. In cold climates, insulation placed on the exterior of the stud wall increases the temperature of the moisture-sensitive wood sheathing and framing and consequently often improves the durability of the assembly by reducing the risk of condensation and associated moisture damage.

Air Barrier

This assembly can accommodate several air barrier strategies. However, often the most straightforward one to use is the exterior sheathing membrane. If the sheathing membrane is to form the air barrier, it must be taped and sealed to ensure continuity. Structural support of the sheathing membrane is provided by the insulation and sheathing on either side of it. Alternatively, a sealed sheathing approach can be used, or potentially an airtight drywall approach or airtight polyethylene, though ensuring continuity of the latter approaches can be arduous. Continuity of the air barrier at transitions and penetrations is critical to its performance. See [Section 07 Airtightness on page 91](#) for further guidance.

Insulation

The stud space can be insulated using a variety of different insulation types, including batts (i.e. mineral wool or fiberglass), blown-in fibrous insulation (i.e. cellulose or fiberglass), or spray foam.

Various types of exterior insulation can be used in split insulation wall assemblies, including permeable insulations such as semi-rigid or rigid mineral wool, or semi-rigid fiberglass, and relatively impermeable insulations such as extruded polystyrene (XPS), expanded polystyrene (EPS), polyisocyanurate (polyiso), and closed-cell spray polyurethane foam. The layers of exterior insulation should be offset from one another to create a more continuous layer and limit potential bypasses in joints and gaps in the insulation. The permeability of the materials is of particular importance with respect to the drying capacity of the wall assembly.

Key Considerations

The method of cladding attachment is important to limit thermal bridging through the exterior insulation while adequately supporting the exterior cladding.

The vapour permeability of the sheathing membrane and exterior insulation should be carefully considered so as not to create a risk of condensation within the assembly, or to reduce the ability of the assembly to dry in the event that incidental wetting occurs. In BC's climate zones, a vapour permeable exterior insulation in combination with an interior vapour barrier typically provides a lower risk wall assembly than does an assembly using impermeable exterior insulation.



Effective R-values | Split-Insulated Wall with Thick Exterior Insulation

	2x4 Framed Wall (R-12 Batts)		2x6 Framed Wall (R-19 Batts)		
	R-value/inch of Exterior Insulation		R-value/inch of Exterior Insulation		
	R-4 / inch	R-5 / inch	R-4 / inch	R-5 / inch	
4.0	27.3	31.3	32.3	32.2	4.0
4.5	29.3	33.8	34.2	38.7	4.5
5.0	31.3	36.3	36.2	41.2	5.0
5.5	33.3	38.8	38.2	43.7	5.5
6.0	35.3	41.3	40.2	46.2	6.0
6.5	37.3	43.8	42.2	48.7	6.5
7.0	39.3	46.3	44.2	51.2	7.0
7.5	41.3	48.8	46.2	53.7	7.5
8.0	43.3	51.3	48.2	56.2	8.0
9.0	47.3	56.3	52.2	61.2	9.0
10.0	51.3	61.3	56.2	66.2	10.0
11.0	55.3	66.3	60.2	71.2	11.0
12.0	59.3	71.3	64.2	76.2	12.0

A 23% framing factor is assumed which is consistent with standard 16" o.c. stud framing practices in Part 9 construction.

Thermal bridging through exterior insulation is not accounted for but may be worth considering depending on the attachment strategy used. Refer to the *Illustrated Guide - R22+ Effective Walls in Residential Construction in British Columbia* for more information.

Split-Insulated Wall Assembly Details Wayfinder

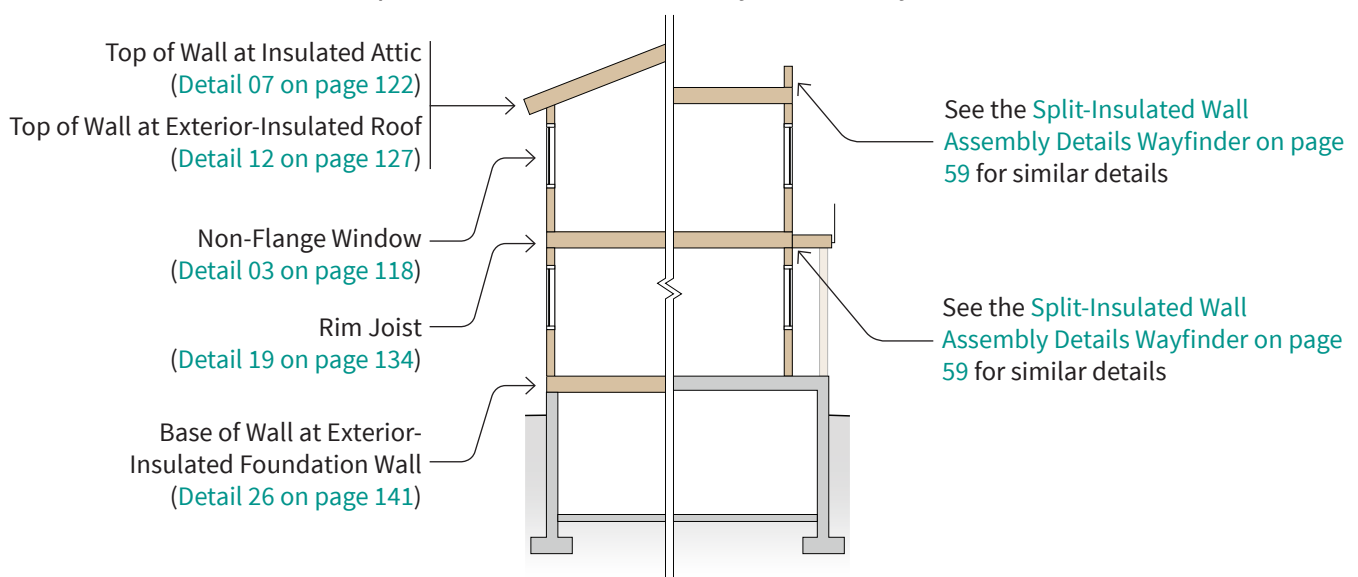

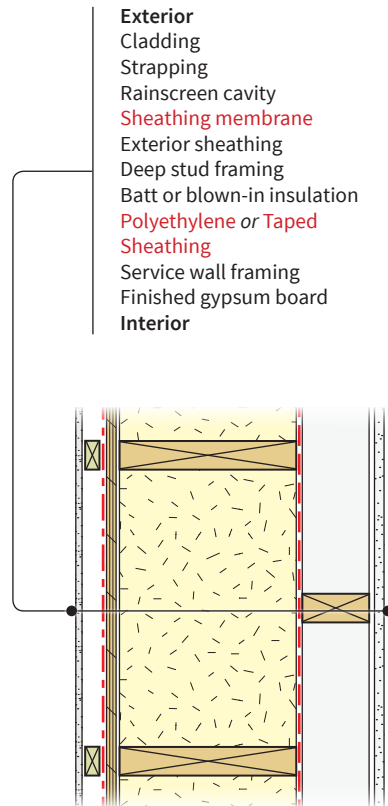

Deep Stud-Insulated Wall with Service Cavity

This above-grade wall assembly consists of a deeper stud cavity created using either deep studs (2x10, 2x12) or engineered wood I-joists and an additional 2x4 service wall constructed on the interior to allow for running of electrical, plumbing, and HVAC services without penetrating the interior air barrier. High effective R-values of the assembly are achieved by filling the increased cavity depth with either batt insulation, blown-in fibrous insulation, or spray foam insulation. There is often no exterior insulation installed in this assembly, so cladding can be attached directly to the wall through vertical strapping and using standard rainscreen detailing. In cold climates, the additional depth of insulation installed on the interior side of the exterior sheathing can slightly decrease the sheathing temperature and consequently increase the risk of condensation. As a result, continuity of the air barrier and installation of an interior vapour barrier are critical to the performance of this assembly, as is the quality of the insulation installation to reduce airflow within the assembly (i.e. convective looping).

Air Barrier

The exterior vapour permeable sheathing membrane or sealed sheathing should be detailed as the primary air barrier for this assembly. In addition to the exterior air barrier, a secondary interior air barrier such as polyethylene sheet or sealed sheathing should be installed between the service wall and deep stud wall and improve the overall assembly airtightness. This double air barrier approach reduces the risk of air movement and condensation within the wall cavity, which increases the durability and thermal performance of the assembly. Note that the interior air barrier transition at the floor line requires careful attention to achieve continuity of the interior air barrier. See [Section 07 Airtightness on page 91](#) for further guidance.

Insulation

The stud space can be insulated using a variety of different insulation types including batt (i.e. mineral wool or fibreglass), blown-in fibrous insulation (i.e. cellulose), or open-cell spray foam. With fibrous fill insulations, higher density blown products with integral binders can be used to prevent settlement within the deep wall cavity. A cost-effective combination of open-cell spray foam and fibrous fill could also be considered to improve airtightness of the assembly and also reduce convective looping within the insulation between the studs. The service wall stud space can either be left empty, or it can be insulated to increase the assembly R-value.

Key Considerations

The quality of the insulation installation is critical to limiting convective looping within the increased wall assembly depth. Such looping can reduce the effectiveness of the insulation and also contribute to moisture accumulation within the assembly.

Continuity of the air barrier and installation of an interior vapour barrier are fundamental to the performance of this assembly, as the slightly decreased exterior sheathing temperature (as compared to standard construction) increases the risk of condensation and related damage.



Effective R-values | Deep Stud-Insulated Wall

Wall Framing	Uninsulated 2x4 Framed Wall			2x4 R-12 Insulated Service Wall		
	R-3.4 / inch	R-4 / inch	R-5 / inch	R-3.4 / inch	R-4 / inch	R-5 / inch
2x6	17.2	18.3	19.9	24.7	25.8	27.4
2x8	21.4	22.9	25.0	28.9	30.4	32.5
2x10	26.3	28.1	30.9	33.8	35.6	38.4
2x12	31.1	33.3	36.6	38.6	40.8	44.1
9.5" I-Joist	26.9	28.8	31.6	34.4	36.2	39.1
11.9" I-Joist	32.7	35.1	38.6	40.2	42.6	46.1
14" I-Joist	37.9	40.7	44.8	45.4	48.2	52.3
16" I-Joist	42.7	45.8	50.6	50.2	53.3	58.1

A 23% framing factor is assumed which is consistent with standard 16" o.c. stud framing practices in Part 9 construction.

Deep Stud-Insulated Wall Assembly Details Wayfinder

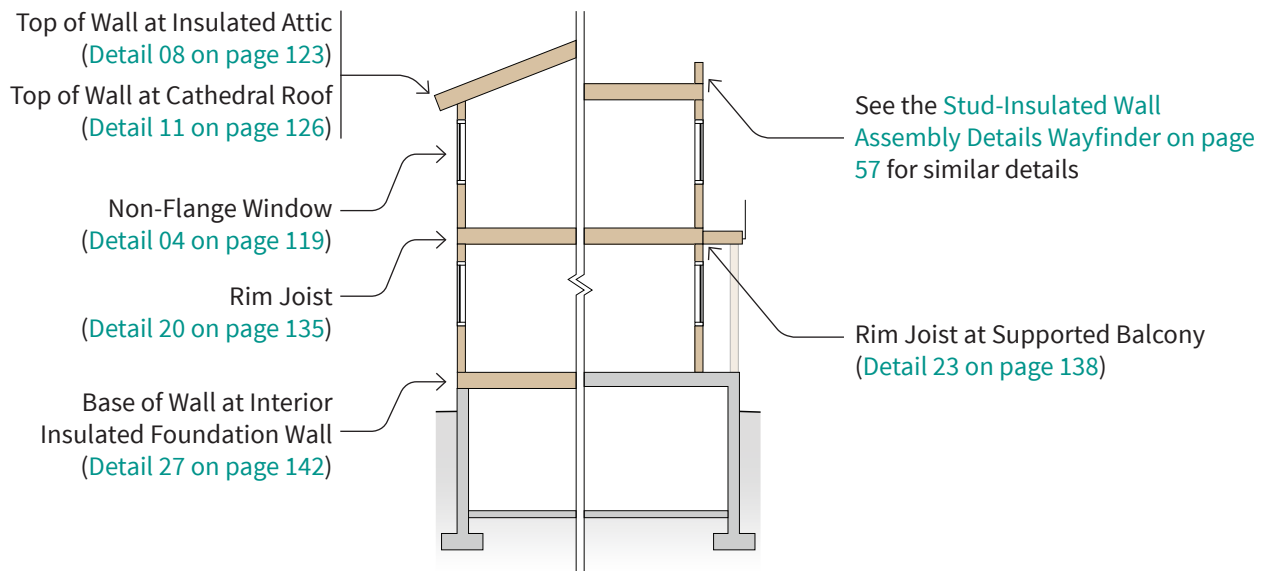

Other Wall Types

Many other wall assembly types exist that can be used as part of an enclosure assembly to meet any of the steps in the Step Code. The key design and construction guidance from this guide is applicable to these various alternative wall assemblies, although it does not cover them in detail.

Exterior-Insulated

This above-grade wall assembly consists of rigid or semi-rigid insulation placed on the exterior of a conventional above-grade, uninsulated wood-frame wall assembly. High effective R-values are achieved by using continuous insulation outside of the structural framing in combination with thermally efficient cladding attachments. In most cases cladding can be supported by strapping fastened with screws through rigid insulation. It is also possible to use low-conductivity cladding attachment systems. The exterior insulation product used in this arrangement should not be sensitive to moisture as it will be exposed some periodic wetting.

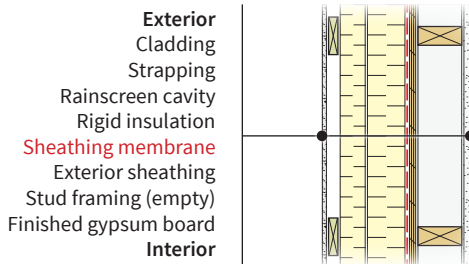

Insulating Concrete Form (ICF)

This wall assembly consists of Insulating Concrete Forms (ICFs) which are manufactured interlocking modular concrete formwork made of rigid expanded polystyrene (EPS) insulation. Once assembled, these forms are filled with concrete and remain in place to provide insulation. High effective R-values of the assembly are achieved by the combination of the interior and exterior form layers. Interior finishes can be installed either directly onto the foam using built-in flanges in the ICF (channels in the ICF foam can be used to provide a space for services), or with an interior stud wall.

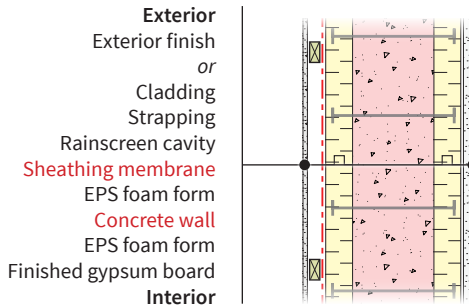

Framed Split Insulation

This assembly consists of conventionally framed wood walls with continuous vertical framing, such as I-joist framing, fastened to the outside of the sheathing and then filled with blown-in insulation. The continuous wood members that penetrate the exterior insulation must be considered in the calculation of the wall effective R-value in a manner similar to that used for stud walls (i.e. parallel paths). Due to the reduction of the insulation performance by the continuous framing, additional insulation thickness is required for this assembly to achieve the same thermal performance as an exterior-insulated assembly.

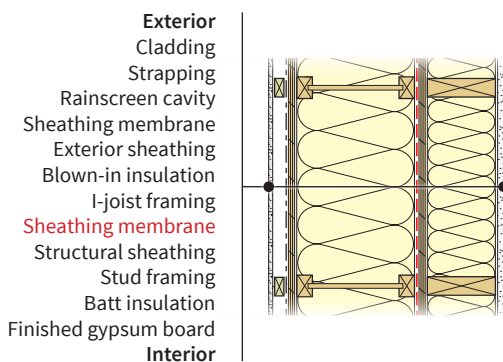

Sloped Roof Assemblies

This section provides information about three different sloped roof assemblies that can be used to achieve various thermal performance targets. The below graph shows the potential effective R-value ranges for each roof type. Refer to the specific assembly section for more information. See also [Additional Resources on page 147](#).

R-value Ranges for Sloped Roof Assemblies Covered in This Guide

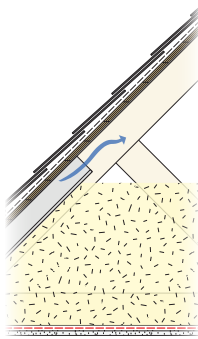

Insulated Attic Sloped Roof
(page 66)

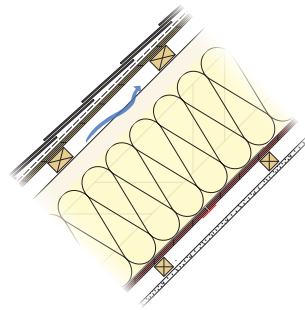

Joist-Insulated Sloped Roof
(page 68)

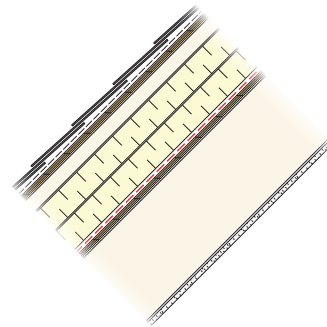

Exterior-Insulated Sloped Roof
(page 70)

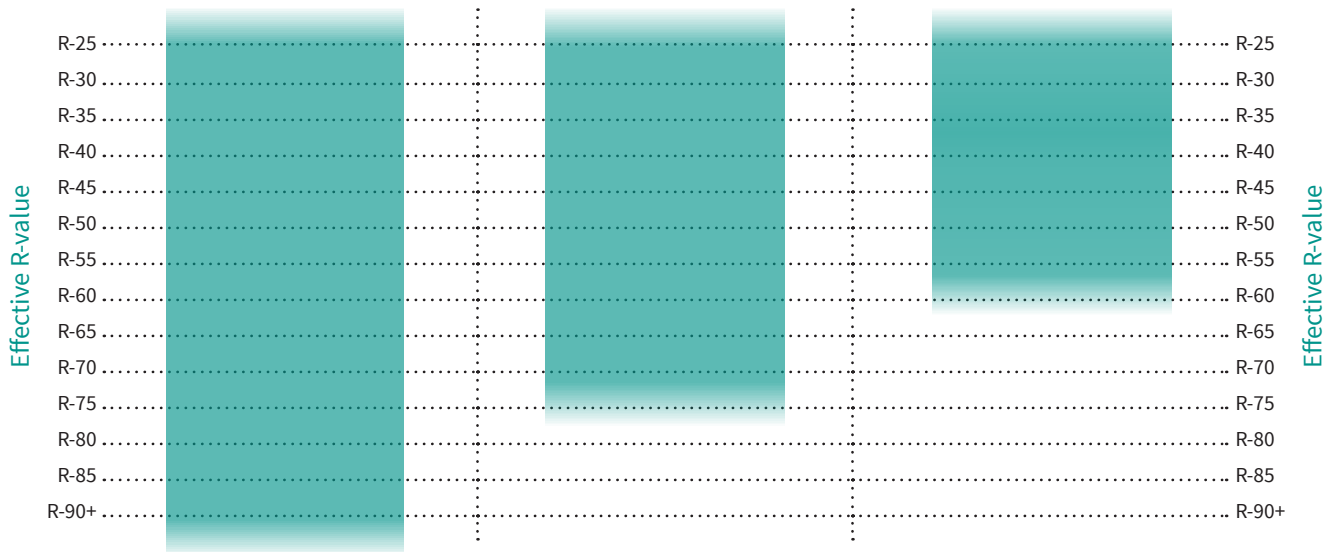

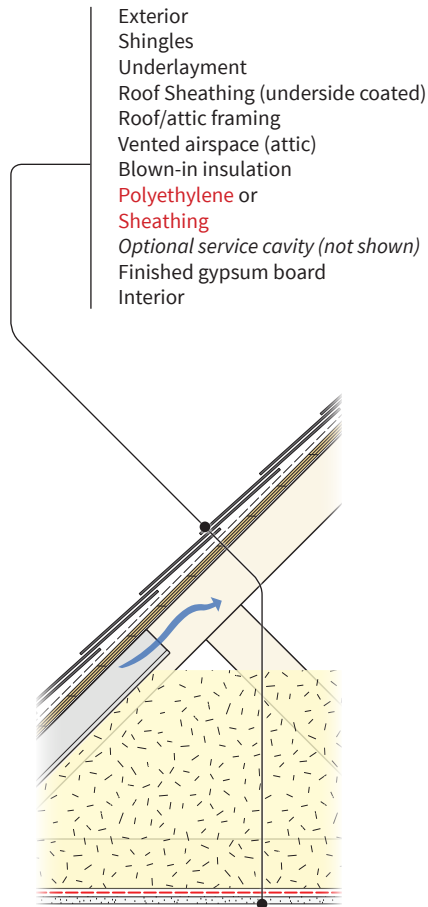

Key Considerations

Besides good roof detailing and watertightness, the performance of the assembly depends on a combination of adequate attic venting and airtightness of the ceiling.

Where the roof sheathing is at risk of condensation and fungal growth due to night sky radiation, an anti-fungal surface coating may be useful to reduce this risk. For additional information on this, see the *Attic Ventilation and Moisture Research Study* published by BC Housing.

A service cavity at the ceiling will reduce the number of penetrations in the ceiling air barrier and improve its airtightness.

Insulated Attic Sloped Roof

This sloped roof assembly consists of framed roof trusses with exterior sheathing at the top side and the ceiling finish below, with the addition of an optional service cavity constructed on the interior of the ceiling finish (not shown) to allow for running of electrical, plumbing, and HVAC services without penetrating the ceiling air barrier. Penetrations in the air barrier can be sealed from inside the attic if needed. High effective R-values of the assembly are achieved by installing insulation above the ceiling and around the bottom chords of the roof trusses. The depth of the insulation can be adjusted to meet the roof R-value requirements, and is only limited by the depth of the roof trusses, with allowance for ventilation. This roof is often the most feasible where R-values above R-80 are required. Continuity of the air barrier and installation of an interior vapour barrier are critical to the performance of this assembly. Note that vented roof assemblies may be at risk of condensation and resulting fungal growth due to night sky radiation at the underside of the roof sheathing, regardless of ceiling airtightness or ventilation levels (see Key Considerations).

Air Barrier

The interior polyethylene sheet or sheathing placed above the ceiling gypsum board (and ceiling service space if present) should be detailed as airtight to provide the air barrier for this assembly. This interior air barrier will prevent the flow of air into the attic space from the interior. The ceiling service cavity can be formed with framing lumber attached to the underside of the attic framing. This strategy is recommended where good ceiling airtightness is required to meet more stringent building airtightness targets. Note that the air barrier transition at the tops of the interfacing walls requires careful attention to achieve continuity of the interior air barrier. See [Section 07 Airtightness on page 91](#) and [Section 09 Details on page 115](#) for further guidance.

Insulation

The joist space can be insulated using a variety of different insulation types including batt (i.e. mineral wool or fibreglass), blown-in fibrous insulation (i.e. cellulose), or spray foam. With fibrous fill insulations, blown products with integral binders can be used to prevent settlement within the attic. A cost-effective combination of closed-cell spray foam and fibrous fill could also be considered in a flash-and-fill application. In this application the spray foam serves as the air barrier.

At the roof perimeter, the roof slope may limit the thickness of the insulation. A raised heel truss should be used where possible in order to maintain insulation thickness. For more guidance on calculating the effective R-value for attics with tapered insulation at the perimeter, see the *Guide for Designing Energy-Efficient Building Enclosures* (see [Additional Resources on page 147](#)).



Effective R-values | Insulated Attic Sloped Roof (2x4 Truss Framing)

Insulation Depth	Without Service Cavity		With 1.5" Service Cavity	
	R-3.4 / inch	R-4 / inch	R-3.4 / inch	R-4 / inch
8"	26.7	30.7	27.6	31.6
10"	33.5	38.7	34.4	39.6
12"	40.3	46.7	41.2	47.6
14"	47.1	54.7	48.0	55.6
16"	53.9	62.7	54.8	63.6
18"	60.7	70.7	61.6	71.6
20"	67.5	78.7	68.4	79.6
24"	81.1	94.7	82.0	95.6
30"	102	119	102	120

A 10% framing factor is assumed for the lower 3.5" of insulation based on raised heel truss framing at 16" o.c.

Components above the vented attic space are not included in the effective R-value calculation.

Insulated Attic Sloped Roof Assembly Details Wayfinder

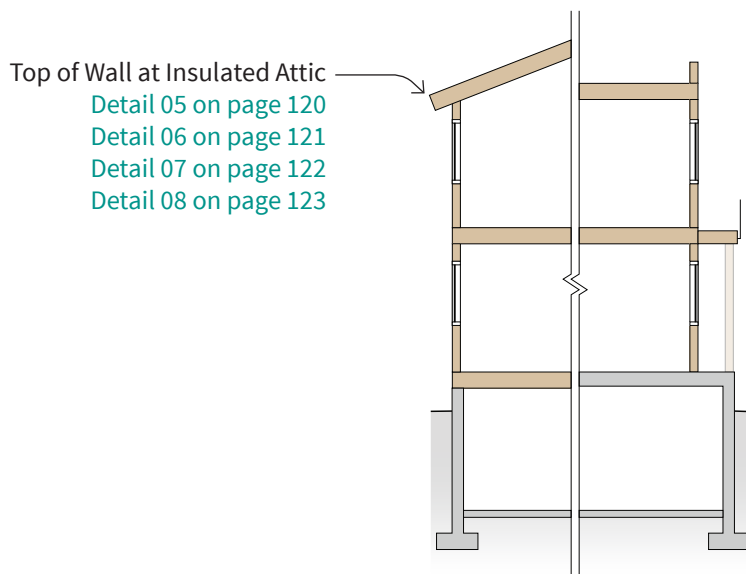

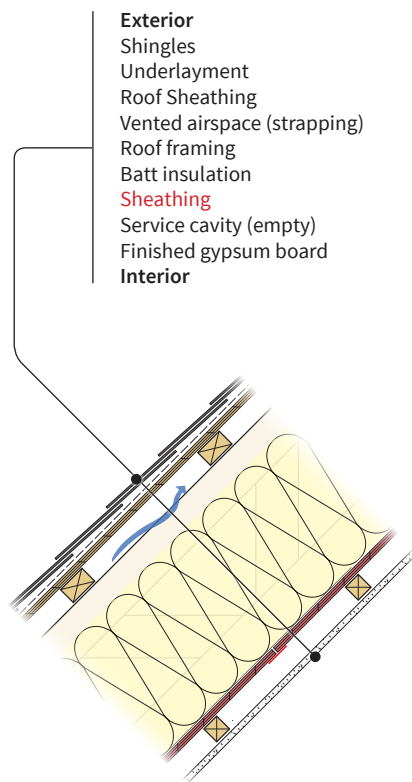

Joist-Insulated Sloped Roof

This sloped roof assembly consists of roof joist framing with exterior sheathing at the top side and the ceiling finish below. A service cavity can be constructed above the ceiling finish to allow for running of electrical, plumbing, and HVAC services without penetrating the ceiling air barrier. Penetrations in the air barrier are sealed at the interior side of the sheathing. High effective R-values of the assembly are achieved by installing insulation in the joist space. The depth of the insulation is limited by the depth of the roof joists, with allowance for ventilation. Engineered trusses can be used to create a deep joist space. Continuity of the air barrier and allowance for adequate ventilation at the top side of the insulation are critical to the performance of this assembly.

Air Barrier

The interior sheathing above the ceiling service space should be detailed as airtight to provide the air barrier for this assembly. This interior air barrier will prevent the flow of air into the roof joist space from the interior. The ceiling service cavity can be formed with dimensional framing lumber. Note that the air barrier transition at the tops of the interfacing walls requires careful attention to achieve continuity of the interior air barrier. See [Section 07 Airtightness on page 91](#) and [Section 09 Details on page 115](#) for further guidance.

Insulation

The joist space can be insulated using a variety of different insulation types including batt (i.e. mineral wool or fibreglass), blown-in fibrous insulation (i.e. cellulose), or spray foam.

The insulation should be held back from the interior surface of the roof sheathing to allow for adequate venting. Cross strapping above the joists provide for ventilation pathways across the top of the insulation in all directions. In some cases, closed-cell spray foam may be installed directly against the interior side of the roof sheathing, with no allowance for ventilation. In these cases, the roof assembly should be carefully designed and constructed to limit the potential for moisture accumulation. For more guidance on using unvented roof assemblies, see the Building Enclosure Design Guide (see [Additional Resources on page 147](#)).

Key Considerations

Besides good roof detailing and watertightness, the performance of the assembly depends on a combination of adequate roof venting and airtightness of the ceiling.

A service cavity at the ceiling will reduce the number of penetrations in the ceiling air barrier and improve its airtightness.



Effective R-values | Joist-Insulated Sloped Roof

Joist Framing	Without Service Cavity		With 1.5" Service Cavity	
	R-3.4 / inch	R-4 / inch	R-3.4 / inch	R-4 / inch
2x8	18.6	20.6	19.5	21.5
2x10	24.1	26.8	25.0	27.7
2x12	29.6	33.0	30.5	33.9
9.5" I-Joist	25.9	29.0	25.9	29.0
11.9" I-Joist	32.7	36.8	32.7	36.8
14" I-Joist	38.8	43.7	38.8	43.7
16" I-Joist	44.6	50.2	44.6	50.2
20" Truss	56.2	63.3	56.2	63.3
24" Truss	67.7	76.3	67.7	76.3

Framing factor is assumed to be 13% for standard joist framing at 16" o.c. and 10% for I-joists and truss framing at 16" o.c.

Components above the vented roof space are not included in the effective R-value calculation.

Insulation depth assumes at least 1" vent space in joist cavity (more is often required and can be achieved with cross strapping)

Joist-Insulated Sloped Roof Assembly Details Wayfinder

Top of Wall at Joist-Insulated Roof
[Detail 09 on page 124](#)
[Detail 10 on page 125](#)
[Detail 11 on page 126](#)

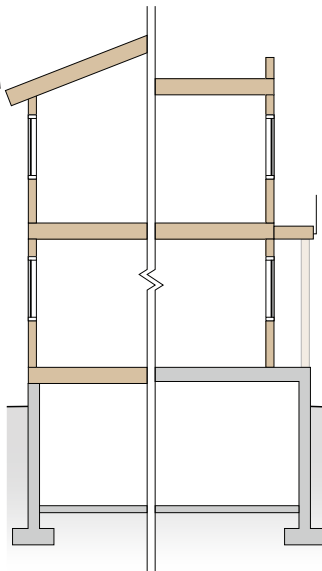

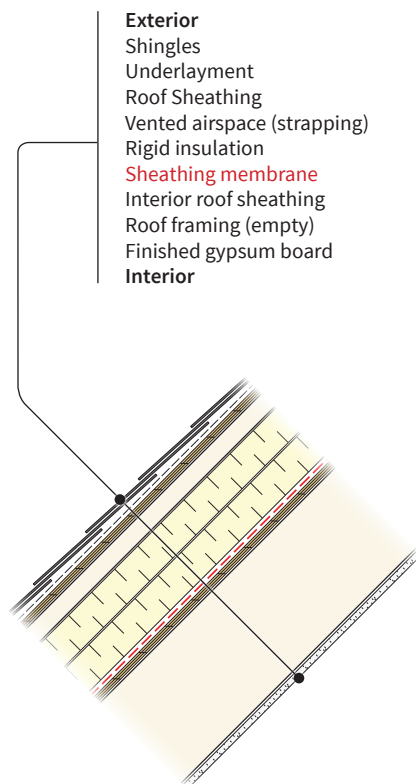

Exterior-Insulated Sloped Roof

This sloped roof assembly consists of rigid insulation placed on the exterior of uninsulated sloped roof framing. High effective R-values of the assembly are achieved by using continuous insulation outside of the structural framing in combination with thermally efficient roof strapping attachments. In most cases roofing and roof sheathing can be supported by strapping fastened with screws through rigid insulation. It is also possible to use low-conductivity roofing attachment systems. The exterior insulation product used in this arrangement should not be sensitive to moisture as it may be exposed to some periodic wetting. The roofing underlayment membrane acts as the water-resistive barrier, while the waterproof membrane is a secondary barrier to leakage to the interior. This second line of protection for rain penetration control makes this assembly very robust.

Air Barrier

The most straightforward air barrier approach for this assembly is to use the self-adhered sheathing membrane over the interior roof sheathing. This membrane can also serve as a secondary barrier to leakage to the interior, especially if metal roofing is used, and can allow incidental moisture to drain to the roof perimeter. It should therefore be detailed both as airtight and as watertight. Continuity of the air barrier at transitions and penetrations is critical to its performance. The air barrier in this assembly is placed above the framing, so penetrations in the ceiling finish do not affect the airtightness. However, service penetrations that must extend through the entire assembly must be made airtight at the sheathing membrane prior to installing the exterior insulation and roofing components. See [Section 07 Airtightness on page 91](#) and [Section 09 Details on page 115](#) for further guidance.

Insulation

Various types of exterior insulation can potentially be used in this assembly including permeable insulations such as semi-rigid or rigid mineral wool, or semi-rigid fiberglass, and relatively impermeable insulations such as extruded polystyrene (XPS), expanded polystyrene (EPS), polyisocyanurate (polyiso), and closed-cell spray polyurethane foam. The insulation type used should be chosen with consideration for the expected heat exposure and thermal cycling the roof will experience, as some foam insulations have been observed to move and shrink in these assemblies. More thermally stable insulation, such as rigid mineral wool, may be more appropriate in some applications.

Insulation placed on the exterior of the roof sheathing increases the temperature of the moisture-sensitive wood sheathing and framing and consequently often improves the durability of the assembly by reducing the risk of condensation and associated moisture damage.

Key Considerations

Detailing to ensure continuity and adequate drainage of both the roofing underlayment and the waterproof membrane at the interfaces and penetrations is a significant factor in the overall performance and durability of the assembly.

Where multiple insulation layers are used, each layer should be offset vertically and horizontally to provide a continuous thermal insulation layer.



Effective R-values | Exterior-Insulated Sloped Roof (Empty Roof Framing Cavity)

Thickness of Exterior Insulation (inches)	R-value of Exterior Insulation	
	R-4 / inch	R-5 / inch
6.0	26.9	32.9
6.5	28.9	35.4
7.0	30.9	37.9
7.5	32.9	40.4
8.0	34.9	42.9
9.0	38.9	47.9
10.0	42.9	52.9
11.0	46.9	57.9
12.0	50.9	62.9

Thermal bridging through the exterior insulation is not accounted for.

Exterior-Insulated Sloped Roof Assembly Details Wayfinder

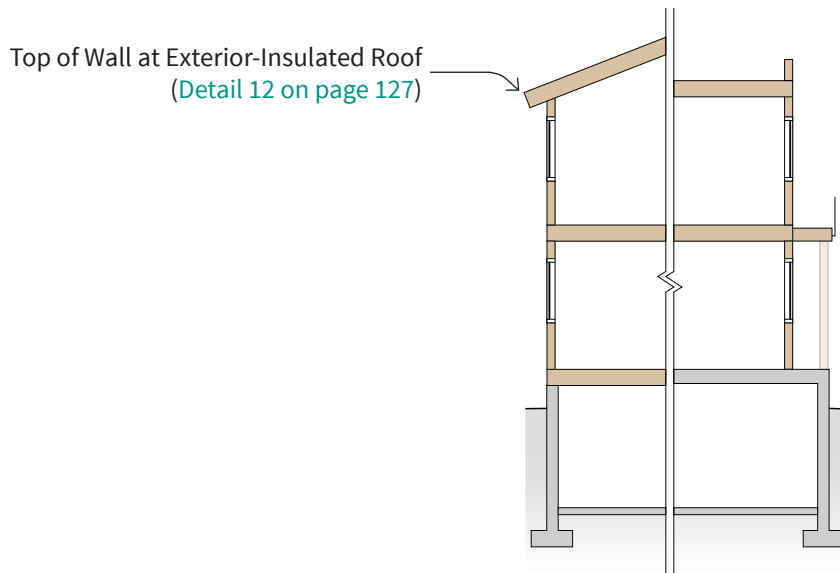

Low-Slope Roof Assemblies

This section provides information about three different low-slope roof assemblies less than 3:12 (i.e. 'flat') that can be used to achieve various thermal performance targets. The below graph shows the potential effective R-value ranges for each roof type. Refer to the specific assembly section for more information. See also [Additional Resources on page 147](#).

R-value Ranges for Flat Roof Assemblies Covered in This Guide

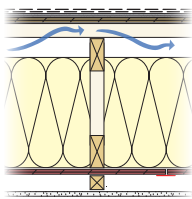

Joist-Insulated Vented Roof
(page 73)

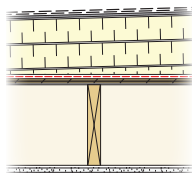

Exterior-Insulated Conventional Roof
(page 75)

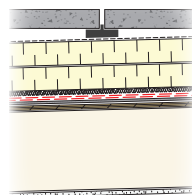

Exterior-Insulated Inverted Roof
(page 77)

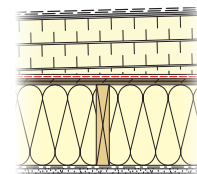

Split-Insulated Roof
(page 78)

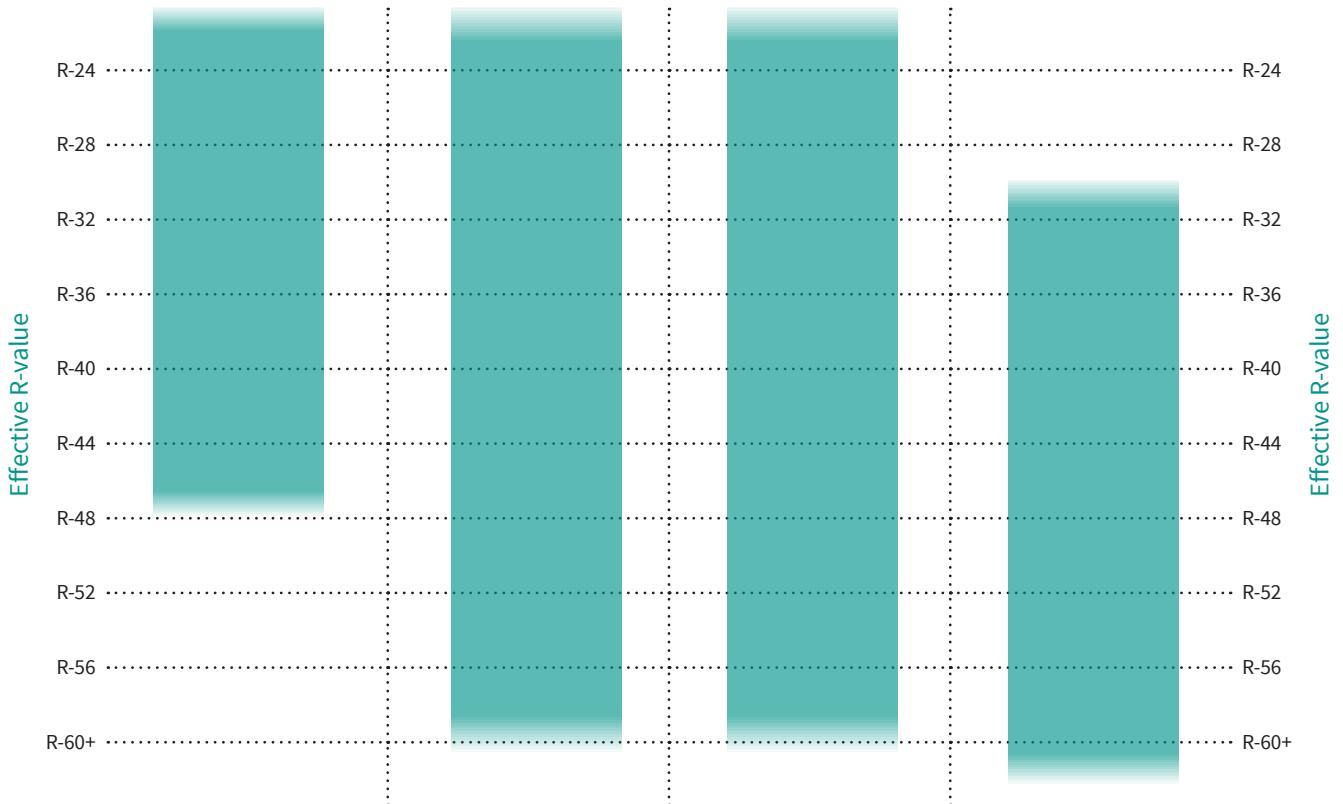

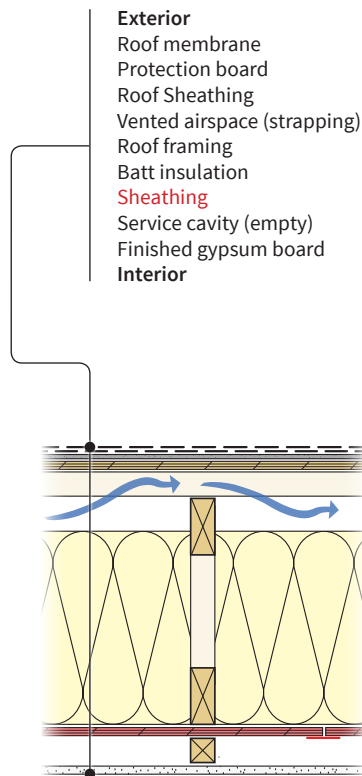

Joist-Insulated Vented Roof

This flat roof assembly consists of a waterproof roof membrane over the exterior sheathing, insulation in the roof joist space, and a service cavity constructed beneath the air barrier and above the ceiling finish to allow for running of electrical, plumbing, and HVAC services. Penetrations in the air barrier are sealed at the interior side of the sheathing. High effective R-values of the assembly are achieved by installing insulation in the joist space. The depth of the insulation is limited by the depth of the roof joists, with allowance for ventilation. Engineered trusses can be used to create a deep joist space. Continuity of the air barrier and waterproof roofing membrane, installation of an interior vapour barrier, and allowance for adequate ventilation at the top side of the insulation are critical to the performance of this assembly.

Air Barrier

The interior sheathing above the ceiling service space should be detailed as airtight to provide the air barrier for this assembly. This interior air barrier will prevent the flow of air into the roof space from the interior. The ceiling service cavity can be formed with dimensional framing lumber. Note that the air barrier transition at the tops of the interfacing walls requires careful attention to achieve continuity of the interior air barrier. See [Section 07 Airtightness on page 91](#) and [Section 09 Details on page 115](#) for further guidance.

Insulation

The attic space can be insulated using a variety of different insulation types including batt (i.e. mineral wool or fibreglass), blown-in fibrous insulation (i.e. cellulose), or spray foam.

The insulation should be held back from the interior surface of the roof sheathing to allow for adequate venting. Cross strapping above the joists provide for ventilation pathways across the top of the insulation in all directions. In some cases, closed-cell spray foam may be installed directly against the interior side of the roof sheathing, with no allowance for ventilation. In these cases, the roof assembly should be carefully designed and constructed to limit the potentiality for moisture accumulation. For more guidance on using unvented roof assemblies, see the Building Enclosure Design Guide (see [Additional Resources on page 147](#)).

Key Considerations

Draining the roof is fundamental to its durable performance and, therefore, the location and sizing of drains, and a positive slope to the drains, are critical design features.

A service cavity at the ceiling will reduce the number of penetrations in the ceiling air barrier and improve its airtightness.

This assembly is at a higher risk of performance issues over the service life of the roof, due to difficulty in achieving adequate venting, sensitivity to interior air leakage, and an assembly configuration where water can be trapped inside undetected. Therefore, its use must be carefully considered.



Effective R-values | Joist-Insulated Vented Roof

Joist Framing	Without Service Cavity		With 1.5" Service Cavity	
	R-3.4 / inch	R-4 / inch	R-3.4 / inch	R-4 / inch
2x8	18.6	20.6	19.5	21.5
2x10	24.1	26.8	25.0	27.7
2x12	29.6	33.0	30.5	33.9
9.5" I-Joist	25.9	29.0	25.9	29.0
11.9" I-Joist	32.7	36.8	32.7	36.8
14" I-Joist	38.8	43.7	38.8	43.7
16" I-Joist	44.6	50.2	44.6	50.2
20" Truss	56.2	63.3	56.2	63.3
24" Truss	67.7	76.3	67.7	76.3

Framing factor is assumed to be 13% for standard joist framing at 16" o.c. and 10% for I-joists and truss framing at 16" o.c.

Components above the vented roof space are not included in the effective R-value calculation.

Insulation depth assumes at least 1" vent space in joist cavity (more is often required and can be achieved with cross strapping)

Joist-Insulated Vented Roof Assembly Details Wayfinder

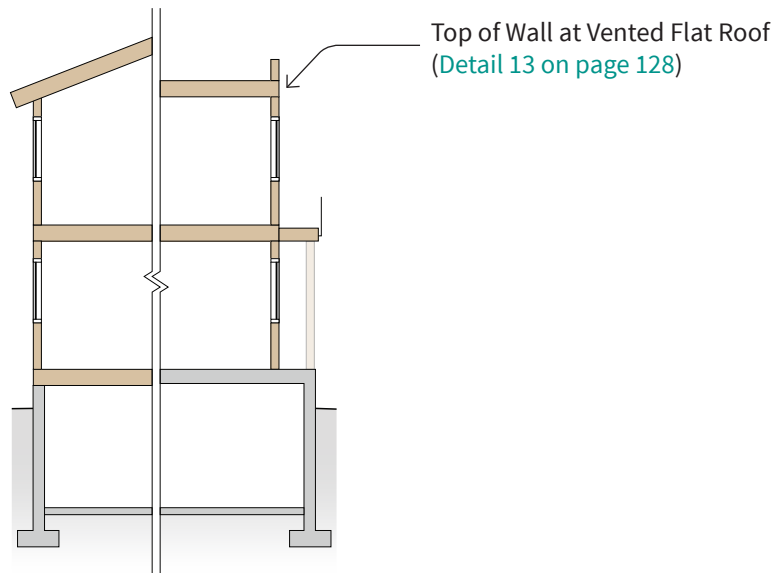

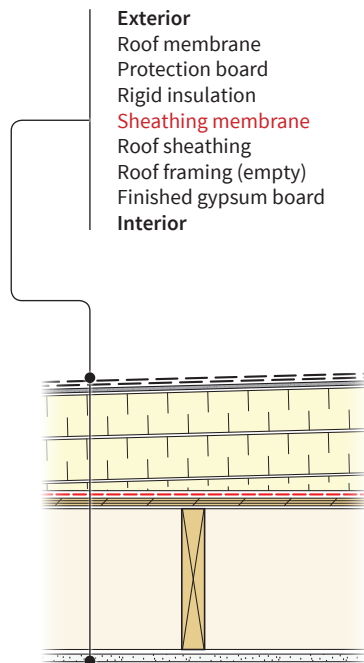

Exterior-Insulated Conventional Roof

This flat roof assembly consists of rigid insulation placed on the exterior of uninsulated roof framing. High effective R-values of the assembly are achieved by using continuous insulation outside of the structural framing in combination with thermally efficient attachments. In most cases, the roofing substrate (such as protection board) can be fastened directly through the rigid insulation into the roof sheathing and framed assembly. The waterproof roofing membrane above the insulation controls all exterior moisture. The sheathing membrane over the roof sheathing is used as the air barrier. Ventilation of this assembly is not necessary as the rigid insulation and roof membrane components are not considered moisture-sensitive.

Air Barrier

The most straightforward air barrier approach for this assembly is to use a self-adhered sheathing membrane over the roof sheathing. Continuity of the air barrier at transitions and penetrations is critical to its performance. This membrane may also be used as temporary roofing during construction, and should therefore be detailed as watertight. The waterproof roofing membrane above the insulation acts as the water-resistive barrier. The sheathing and framing are protected and able to readily dry, so there is reduced risk of moisture problems with this assembly. See [Section 07 Airtightness on page 91](#) and [Section 09 Details on page 115](#) for further guidance.

Insulation

Various types of rigid insulation can potentially be used in this assembly including rigid mineral wool, extruded polystyrene (XPS), expanded polystyrene (EPS), and polyisocyanurate (polyiso). The insulation type used should be chosen with consideration for the expected heat exposure and thermal cycling the roof will experience, as some foam insulations have been observed to move and shrink in these assemblies. More thermally stable insulation, such as rigid mineral wool, may be more appropriate in some applications.

Insulation placed on the exterior of the roof sheathing increases the temperature of the moisture-sensitive wood sheathing and framing and consequently often improves the durability of the assembly by reducing the risk of condensation and associated moisture damage.

If the insulation includes tapered layers to provide roof slope, the roof effective R-value calculation should account for the variation in insulation thickness, or only account for the minimum insulation thickness. For guidance on calculating the R-value of tapered insulation, see the Guide for Designing Energy-Efficient Building Enclosures (see [Additional Resources on page 147](#)).

Key Considerations

An expanded polystyrene (EPS) sloping package installed with the roof insulation as shown is often the simplest way to achieve the required sloping.

Detailing to ensure continuity of the waterproof membrane at the interfaces and penetrations is a significant factor in the overall performance and durability of the assembly.

Multiple insulation layers should be offset to provide a continuous thermal insulation layer. This roof relies on the secure attachment of the rigid insulation for the adequate wind uplift resistance of all assembly components. Insulation attachment methods include roofing adhesives and/or pin fasteners through the insulation to the roof framing.



Effective R-values | Exterior-Insulated Conventional Roof (Empty Roof Framing Cavity)

Thickness of Exterior Insulation (inches)	R-value of Insulation		
	R-4 / inch	R-5 / inch	R-5.6 / inch
6.0	26.9	32.9	36.5
6.5	28.9	35.4	39.3
7.0	30.9	37.9	42.1
7.5	32.9	40.4	44.9
8.0	34.9	42.9	47.7
9.0	38.9	47.9	53.3
10.0	42.9	52.9	58.9
11.0	46.9	57.9	64.5
12.0	50.9	62.9	70.1

Thermal bridging through the exterior insulation is not accounted for.

R-value of an insulation sloping package is not accounted for.

Exterior-Insulated Conventional Roof Assembly Details Wayfinder

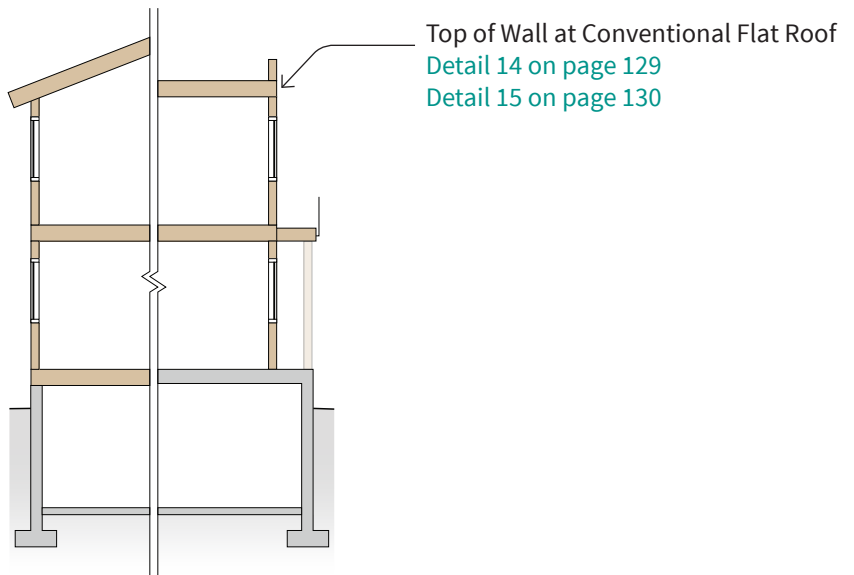

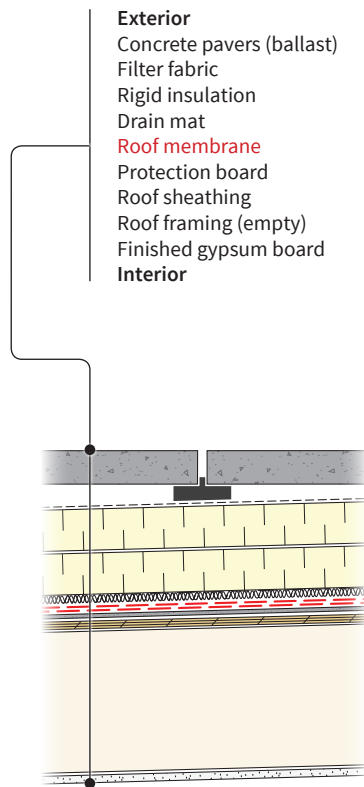

Exterior-Insulated Inverted (Protected Membrane) Roof

This flat roof assembly consists of rigid insulation placed on the exterior of the waterproof roofing membrane and uninsulated roof framing. High effective R-values of the assembly are achieved by using continuous insulation outside of the structural framing. In most cases the insulation can be held in place with the roof ballast or pavers, and does not require fasteners. This roof type is also used in green roofs. The exterior insulation product used in this arrangement should not be sensitive to moisture as it will be exposed to regular wetting. The waterproof roofing membrane beneath the insulation controls all exterior moisture and is used as the air barrier. The drain mat beneath the insulation provides an unobstructed pathway for water that reaches the roofing membrane to reach the roof drains.

Air Barrier

The most straightforward air barrier approach for this assembly is to use the waterproof roofing membrane as the air barrier, since it must be watertight anyways. Continuity of the air barrier at transitions and penetrations is critical to its performance, especially since these penetrations must also resist moisture entry. The sheathing and framing are protected and able to readily dry, so there is reduced risk of moisture problems with this assembly. See [Section 07 Airtightness on page 91](#) for further guidance.

Insulation

It is important that the selected insulation product is extremely moisture tolerant as it will be exposed to significant wetting in this roofing application. The insulation must be secured in place with a ballast such as gravel, pavers, or a green roof system. The ballast must be sufficiently heavy to withstand both the wind uplift, as well as the potential buoyancy forces from water that may accumulate on the roof. This can require significant weight and may not be feasible with insulation levels above R-40, depending on the insulation product used.

Insulation placed on the exterior of the roof sheathing increases the temperature of the moisture-sensitive wood sheathing and framing and consequently often improves the durability of the assembly by reducing the risk of condensation and associated moisture damage.

The thermal performance of the exterior-insulated inverted (protected membrane) roof assembly is similar to the interior insulated conventional assembly (see [page 75](#)), with some improvements since there is minimal thermal bridging through the insulation.

Key Considerations

The waterproof membrane in this assembly is protected from loading – including thermal cycling, ultraviolet light and pedestrian traffic – and therefore can have a longer service life than membranes placed in more exposed environments. Note that the assembly is difficult to maintain and repair, especially on green roofs, because access to the membrane requires removal of the ballast and insulation.

Detailing to ensure continuity and adequate drainage of the waterproof membrane at the interfaces and penetrations is a significant factor in the overall performance and durability of the assembly.



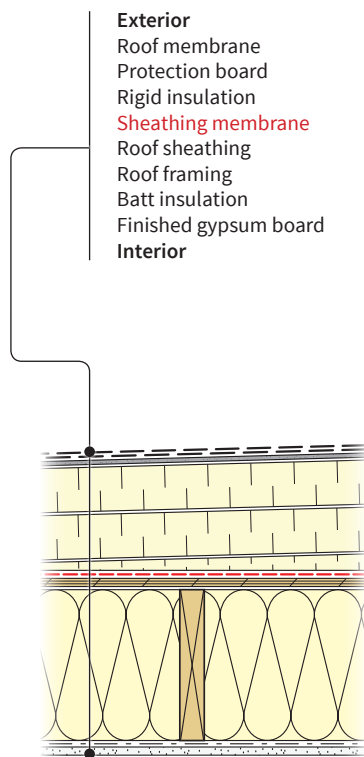

Key Considerations

The split-insulated roof assembly must be carefully designed to ensure the interior insulation does not result in condensation risk at the roof sheathing. Where possible, split-insulated roofs should be designed using hygrothermal design software that considers the climate and interior conditions that the assembly will be exposed to.

Multiple insulation layers should be offset to provide a continuous thermal insulation layer. This roof relies on the secure attachment of the rigid insulation for the adequate wind uplift resistance of all assembly components. Insulation attachment methods include roofing adhesives and/or pin fasteners through the insulation to the roof framing.

Split-Insulated Roof

This flat roof assembly consists of rigid insulation placed on the exterior of insulated roof framing. High effective R-values of the assembly are achieved by using continuous insulation outside of the structural framing in combination with thermally efficient attachments, and supplemented by insulation in the framing cavity. In most cases the roofing substrate such as protection board can be fastened directly through the rigid insulation into the roof sheathing and framed assembly. The waterproof roofing membrane above the insulation controls all exterior moisture. The sheathing membrane over the roof sheathing is used as the air barrier and vapour retarder. This split-insulated approach must be carefully designed to ensure the interior insulation does not result in condensation risk at the roof sheathing.

Air Barrier

The most straightforward air barrier approach for this assembly is to use the self-adhered sheathing membrane over the roof sheathing. Continuity of the air barrier at transitions and penetrations is critical to its performance. This membrane may also be used as temporary roofing during construction, and should therefore also be detailed as watertight. See [Section 07 Airtightness on page 91](#) and [Section 09 Details on page 115](#) for further guidance.

Insulation

Various types of rigid insulation can potentially be used above the sheathing in this assembly including rigid mineral wool, extruded polystyrene (XPS), expanded polystyrene (EPS), and polyisocyanurate (polyiso). Insulation placed at the interior can be batt (i.e. mineral wool or fibreglass), blown-in fibrous insulation (i.e. cellulose), or spray foam. The ratio of interior-to-exterior insulation R-value in this assembly must be carefully considered to avoid risking condensation at the underside of the roof sheathing. Split-insulated roofs should be designed using hygrothermal design software or calculations that consider the climate zone and interior conditions that the assembly will be exposed to. As a starting point, the assembly should have at least 50% of the total nominal insulation R-value placed at the exterior of the roof sheathing.

Interior vapour control is also important in this assembly in order to prevent excessive ambient moisture from reaching the sheathing, without trapping moisture that may enter the assembly. A relatively more permeable interior vapour barrier such as a smart vapour retarder or vapour retarder paint could be used.

The thermal performance of the split-insulated roof assembly is a combination of the joist insulation (see [page 73](#)) and the continuous exterior insulation (see [page 75](#) and [page 77](#)).



Below-Grade Walls and Slab

This section provides information about three different below-grade concrete wall assemblies and a concrete slab assembly that can be used to achieve various thermal performance targets. The below graph shows the potential effective R-value ranges for each assembly. See also [Additional Resources on page 147](#).

R-value Ranges for Below-Grade Assemblies Covered in This Guide

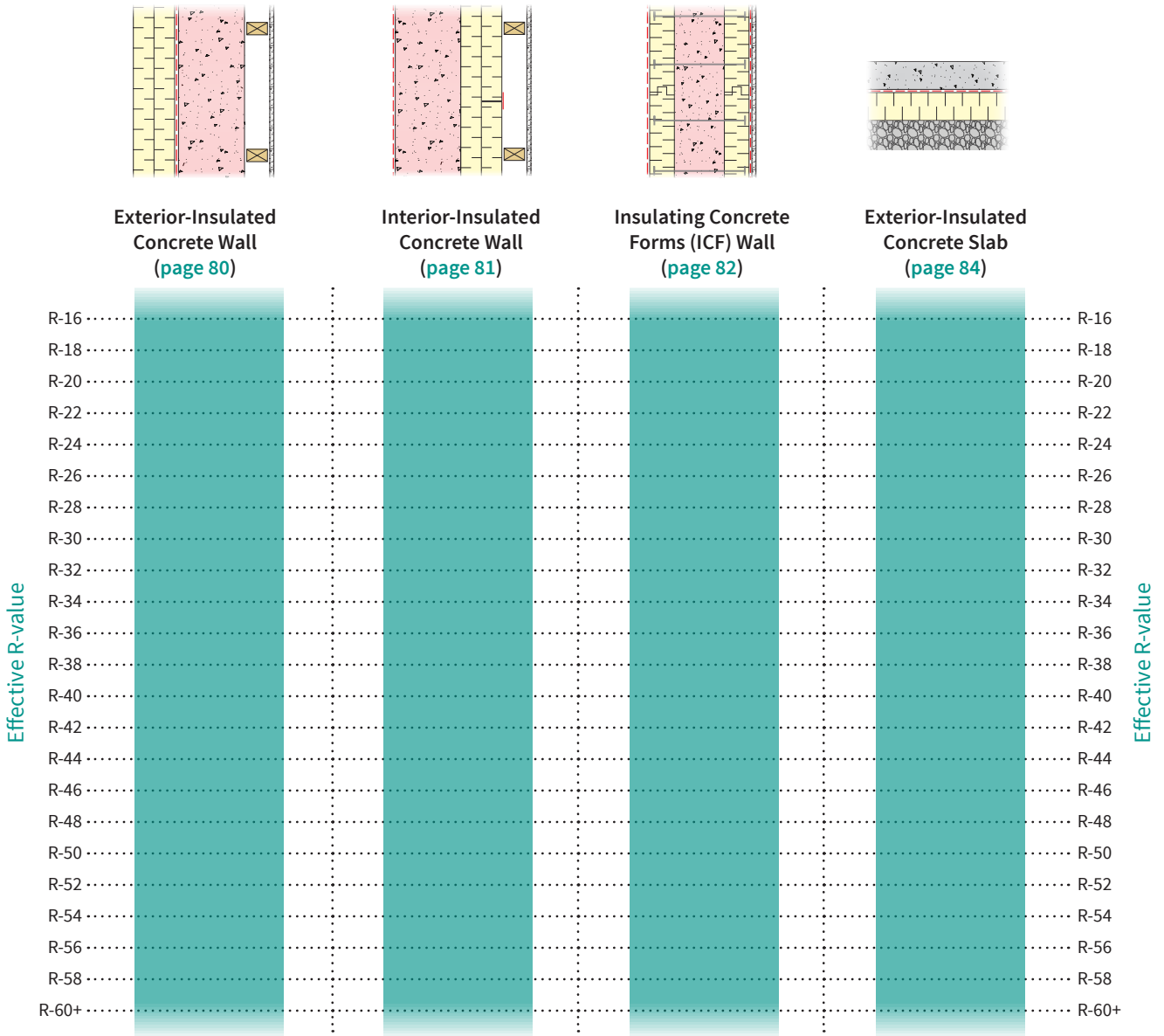

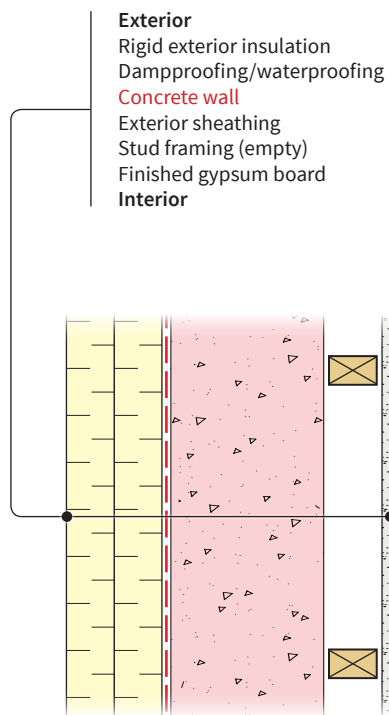

Exterior-Insulated Concrete Wall

This below-grade wall assembly consists of rigid insulation placed on the exterior of the concrete foundation wall. A wood stud wall is often constructed on the interior of the concrete wall to provide room for electrical and plumbing services. High effective R-values of the assembly are achieved by using continuous insulation outside of the concrete structure. The insulation product used in this arrangement should be highly moisture tolerant and suitable for below-grade applications. In cold climates, insulation placed on the exterior of the wall increases the temperature of the concrete and consequently often reduces the risk of condensation and associated damage to moisture-sensitive interior wall components and finishes. Drainage is provided at the exterior of the insulation to eliminate hydrostatic pressure on the wall assembly and reduce the risk of water ingress.

Air Barrier

The concrete wall is the most airtight element in this assembly and is usually the most straightforward to make continuous with adjacent building enclosure assemblies such as the concrete floor slab (or air barrier below the slab) and above-grade walls. See [Section 07 Airtightness on page 91](#) and [Section 09 Details on page 115](#) for further guidance.

Insulation

Various types of insulation can be used including extruded polystyrene, high density expanded polystyrene and rigid mineral wool. It is important that the selected insulation product is extremely moisture tolerant as it can potentially be exposed to significant wetting in this below-grade application.

The exterior insulation in this assembly will maintain the concrete structure at closer to indoor temperatures, consequently typically reducing the risk of condensation and associated damage.

Key Considerations

Drainage to deflect water away from the foundation wall is important to the long-term performance of this wall assembly with respect to water penetration.

Detailing of the wall to ensure continuity of the water-resistive barrier, air barrier, vapour barrier, and insulation at the below-grade to above-grade wall transition is important to the overall performance.

The exterior of foundation walls can be difficult and expensive to access post-construction. It is prudent to design these assemblies conservatively with respect to water penetration and to use durable materials.



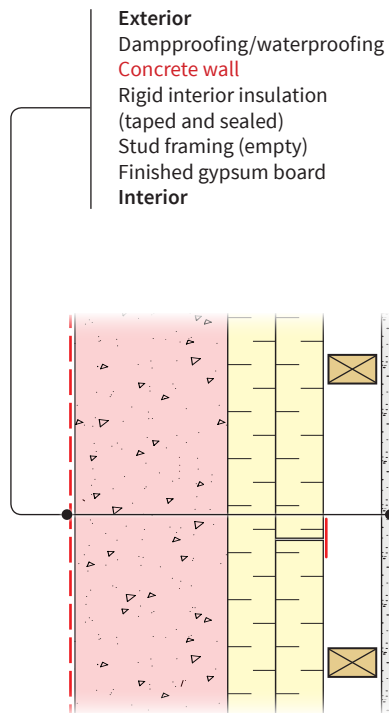

Interior-Insulated Concrete Wall

This below-grade wall assembly consists of rigid or spray-in-place air-impermeable moisture tolerant insulation placed on the interior of the concrete foundation wall. High effective R-values of the assembly are achieved by using continuous insulation placed directly against the concrete foundation wall behind the interior stud framed service wall. Placement of insulation on the interior of the concrete foundation wall results in cooler concrete interior surface temperatures and consequently an increased risk of condensation and associated damaged. A robust interior air barrier should be installed to limit this risk. Note that batt insulation alone in the interior stud cavity is not a recommended approach for below-grade wall assemblies.

Air Barrier

The concrete wall is the most airtight element in this assembly and is usually the most straightforward element to make continuous with adjacent assemblies such as the concrete floor slab (or air barrier below the slab) and above-grade walls. However, with interior insulation approaches it is also important that an interior airtight layer be maintained to limit the potential for interior air to flow past the insulation and come in contact with the interior surface of the colder concrete foundation wall. This is often achieved through sealing of joints between insulation boards or by using spray foam products.

Insulation

Extruded polystyrene (XPS), high density expanded polystyrene (EPS) and closed-cell spray polyurethane foam insulation are typically most appropriate for this application because they are both insensitive to potential moisture within the concrete and are relatively air and vapour impermeable. Air permeable insulation products are not generally recommended unless other measures are considered, such as installing airtight polyethylene or drywall.

Key Considerations

Drainage to deflect water away from the foundation wall is important to the long-term performance of this wall assembly with respect to water penetration.

Detailing of the wall to ensure continuity of the water-resistive barrier, air barrier, vapour barrier, and insulation at the below-grade to above-grade wall transition is important to the overall performance.

An interior air barrier should be maintained to limit the potential for interior air to flow past the insulation and come in contact with the cold concrete foundation wall.



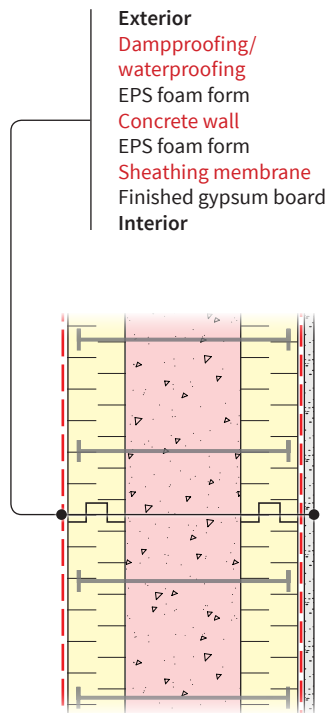

Insulating Concrete Forms (ICF) Wall

This wall assembly consists of Insulating Concrete Forms (ICFs), which are manufactured interlocking modular concrete forms made of rigid expanded polystyrene (EPS) insulation. Once assembled, these forms are filled with concrete and remain in place to provide insulation. High effective R-values of the assembly are achieved by the combination of the interior and exterior form layers, with additional layers added as needed. In below-grade applications, a dampproofing or waterproofing material should be applied to the exterior form insulation. Interior finishes can be installed either directly onto the foam using built-in flanges in the ICF (channels in the ICF foam can be used to provide a space for services), or with an interior stud wall. Refer to the manufacturers data for more information on ICF construction.

Air Barrier

The concrete wall is the most airtight element in this assembly but because it is cast into permanent foam formwork, a dedicated air barrier membrane might need to be installed unless the concrete is exposed directly. The expanded polystyrene form modules are not considered airtight due to all the joints. An interior air barrier membrane such as a self-adhered membrane or polyethylene is the most straightforward element to make continuous with adjacent assemblies such as the concrete floor slab (or air barrier below the slab) and above-grade walls. See [Section 07 Airtightness on page 91](#) and [Section 09 Details on page 115](#) for further guidance.

Insulation

The expanded polystyrene foam modules act as the insulation layers in this assembly. If additional insulation is desired beyond what is provided in the thickness of the manufactured components, additional foam insulation layers could be added to the exterior or interior. Various types of insulation can be used including extruded polystyrene (XPS), semi rigid mineral wool and high density expanded polystyrene (EPS).

Key Considerations

Drainage to deflect water away from the foundation wall is important to the long-term performance of this wall assembly with respect to water penetration.

Detailing of the wall to ensure continuity of the water-resistive barrier, air barrier, vapour barrier, and insulation at the below-grade to above-grade wall transition is important to the overall performance.

The exterior of foundation walls can be difficult and expensive to access post-construction. Therefore, it is prudent to design these assemblies conservatively with respect to water penetration and to use durable materials.



**Effective R-values | Exterior / Interior / ICF Insulated
8" Concrete Wall Assemblies
(With Framed Service Wall)**

	R-value of Insulation		
	R-4 / inch	R-5 / inch	R-6 / inch
2.0	10.6	12.6	14.6
3.0	14.6	17.6	20.6
4.0	18.6	22.6	26.6
5.0	22.6	27.6	32.6
6.0	26.6	32.6	38.6
7.0	30.6	37.6	44.6
8.0	34.6	42.6	50.6
9.0	38.6	47.6	56.6
10.0	42.6	52.6	62.6
11.0	46.6	57.6	68.6
12.0	50.6	62.6	74.6

Thickness of Total Insulation (inches)

Below-Grade Wall Assembly Details Wayfinder

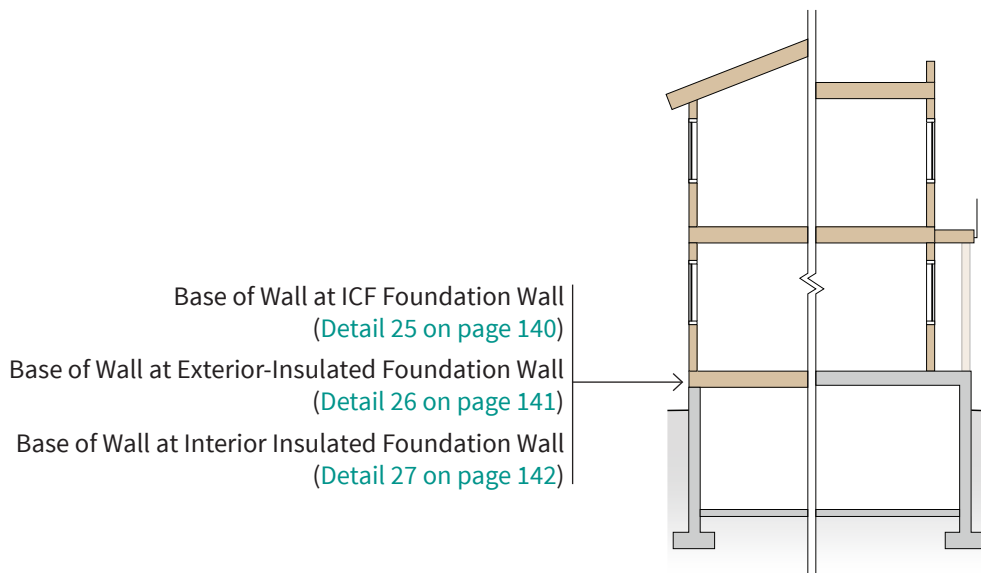

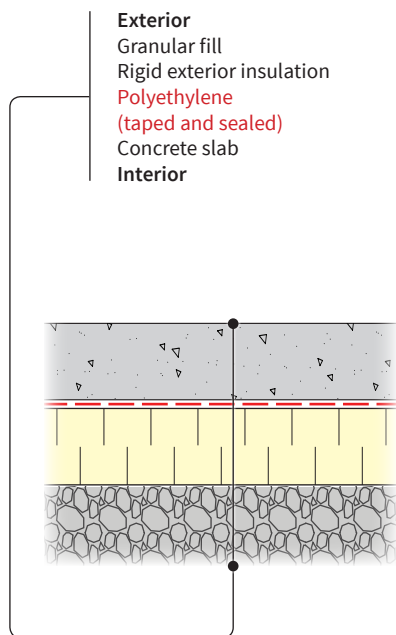

Exterior-Insulated Concrete Slab

This below-grade slab assembly consists of rigid insulation placed beneath the polyethylene air barrier and concrete slab. High effective R-values of the assembly are achieved by using continuous insulation outside of the concrete slab. The insulation product used in this arrangement should be highly moisture-tolerant and suitable for below-grade applications. In cold climates, insulation placed on the exterior of the slab increases the temperature of the concrete and consequently often reduces the risk of condensation and associated damage to moisture-sensitive interior floor components and finishes. A capillary break is provided between the slab assembly and the ground by a layer of coarse clean granular fill to eliminate hydrostatic pressure on the floor assembly and reduce the risk of water ingress.

Air Barrier

The polyethylene sheet beneath the concrete slab is the air barrier in this assembly and is usually the most straightforward to make continuous with adjacent building enclosure assemblies such as the concrete wall. The polyethylene sheet should be taped and sealed at all laps and penetrations. Besides providing a robust air barrier, the polyethylene functions as the vapour barrier, and as part of the soil gas mitigation system where required. A high-density polyethylene (HDPE) sheet is recommended as it should be robust enough to remain continuous even with foot traffic while exposed before the concrete slab is placed. See [Section 07 Airtightness on page 91](#) and [Section 09 Details on page 115](#) for further guidance.

Insulation

Various types of insulation can be used including extruded polystyrene, high-density expanded polystyrene, rigid mineral wool and closed-cell spray foam. It is important that the selected insulation product is extremely moisture-tolerant as it can potentially be exposed to significant wetting in this below-grade application.

The exterior insulation in this assembly will maintain the concrete slab at closer-to-indoor temperatures, typically reducing the risk of condensation and associated damage.

Key Considerations

The exposed insulation and air barrier membrane are susceptible to damage during construction and should be carefully monitored and protected until they can be permanently covered.

A major factor in the long-term performance of the floor assembly for moisture penetration control is the use of a properly installed and well-maintained below-grade drainage system.



Effective R-values | Exterior-Insulated 4” Concrete Slab Assemblies

	R-value of Insulation		
	R-4 / inch	R-5 / inch	R-6 / inch
2.0	9.1	11.1	13.1
3.0	13.1	16.1	19.1
4.0	17.1	21.1	25.1
5.0	21.1	26.1	31.1
6.0	25.1	31.1	37.1
7.0	29.1	36.1	43.1
8.0	33.1	41.1	49.1
9.0	37.1	46.1	55.1
10.0	41.1	51.1	61.1
11.0	45.1	56.1	67.1
12.0	49.1	61.1	73.1

Thickness of Exterior Insulation (inches)

Below-Grade Slab Assembly Details Wayfinder

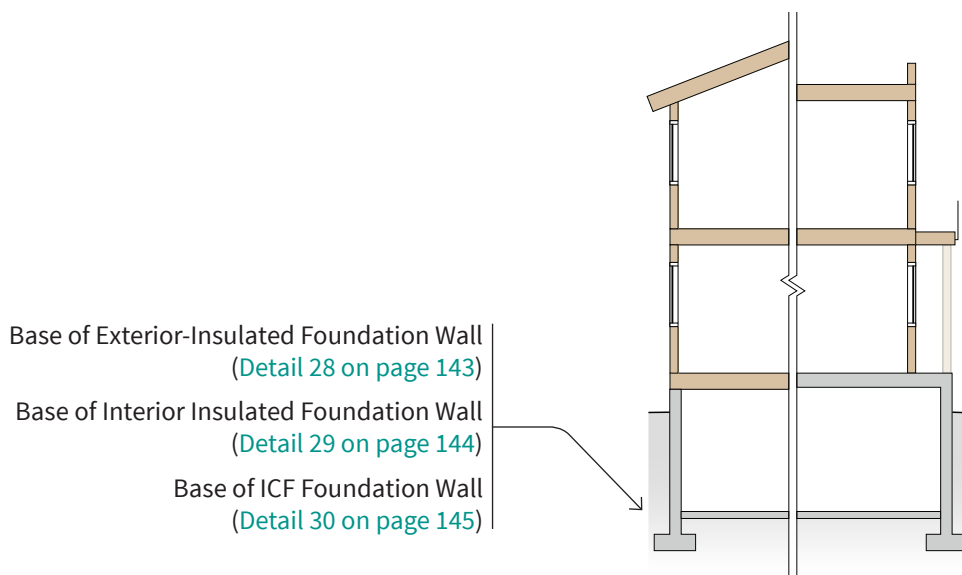

Window-to-Wall Ratio

Besides the selection of windows and doors for thermal performance and airtightness, the overall energy performance of the building is also impacted by the amount of glazing. In general, the fewer the openings the better.

Windows and Doors

This section provides information about the various fenestration product types, including frame options and glass arrangements, that can be used to achieve various thermal performance targets. The graph below shows the potential U-value ranges for different high-performance windows, though options for window types go well beyond what is shown. See also [Additional Resources on page 147](#).

R-value Ranges for Window Options

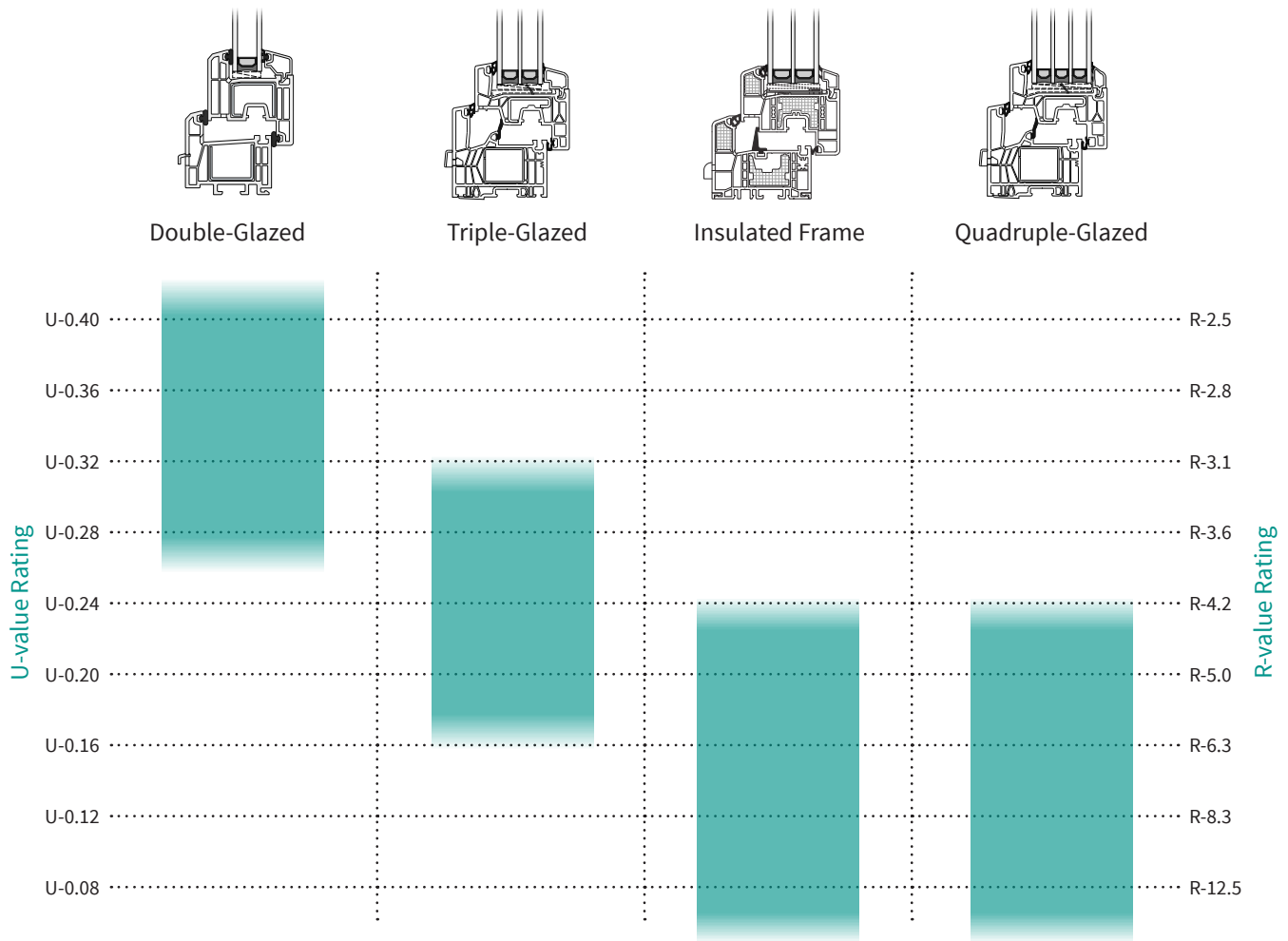

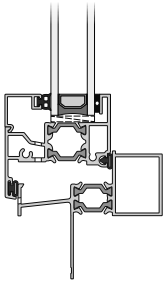

Thermally broken
aluminium frame windows

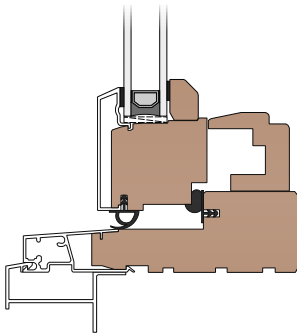

Wood-frame
(with aluminium cladding)

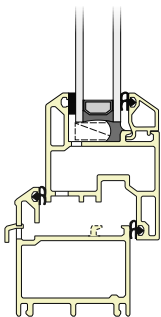

Fibreglass frame

Energy Performance of Windows and Doors

Window and door energy performance properties are determined according to standards developed by the Canadian Standards Association (CSA) or the U.S.-based National Fenestration Rating Council (NFRC). Thermal testing consists of controlled laboratory experiments for calibration of finite two-dimensional computer simulation models. There are three primary properties that describe the energy performance of fenestration products: the U-value (inverse of R-value), Solar Heat Gain Coefficient (SHGC), and air leakage.

U-value (also called U-factor) is a measure of the overall rate of heat transfer through the entire fenestration product. The rate of heat transfer varies through the frame, the glass edge and the centre of glass; the U-value represents the overall rate of heat transfer through all of these components. The U-value is expressed in either imperial units (Btu/h·ft²·F) or metric units (W/m²·K). Lower U-values are always desirable as they represent less heat transfer. **Solar Heat Gain Coefficient** is the proportion of incident solar radiation transferred through the glass and framing of a product. **Air leakage** is a measure of the rate of airflow through a fenestration system.

The energy performance for various fenestration types and glazing configurations will vary between manufacturers and products, and should be determined using specific product data for each window. However, general guidance for selecting windows is given below.

Window Frame Material

Window and glazed door frames are typically constructed of aluminium, steel, vinyl (rigid PVC), wood or fibreglass. Aluminium and steel frames are usually not appropriate for projects requiring thermally efficient windows as they are very conductive, unless thermally broken with low-conductivity thermal breaks. Frames constructed of wood, PVC and fibreglass all have similar low-conductivity properties, and therefore, perform well from a thermal efficiency standpoint. Further improvements can be made in these frames by filling the voids and air spaces within the frames with rigid insulation. Further insulated wood, PVC or fibreglass frames are typically used in very high-performance windows which may be necessary in buildings aiming to meet the Upper Steps of the Step Code.

Airtightness

The product airtightness is tested under laboratory conditions and reported as an air leakage rate. The primary air leakage pathway in most fenestration products is around the perimeter of operable portions of the frame, where it interfaces with gaskets. Good airtight windows and doors uses at least two and often three gaskets to provide airtightness across multiple surfaces of the frame. Note that slider windows generally have lower airtightness than casement windows.



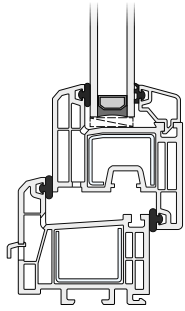

Double-glazed vinyl
(dual gaskets)

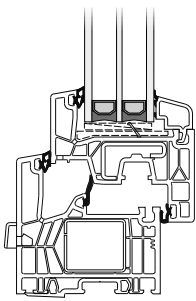

Triple-glazed vinyl
(triple gaskets)

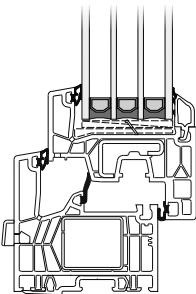

Quadruple-glazed vinyl
(triple gaskets)

Insulating Glass Unit (IGU)

IGUs are available with two (double-glazed), three (triple-glazed), or even four (quadruple-glazed) panes of glass separated by an air space using spacer bars. While the glass layer generally provides good thermal resistance, the air space between panes can have a big impact on overall thermal performance. IGUs can be manufactured with a gas fill between the panes of glass to improve their thermal performance. Using an inert gas like Argon instead of atmospheric air inside the IGU will reduce heat transfer between the glass panes. Argon-filled IGUs with one or multiple low-e coatings are often used in high-performance windows.

IGUs can also be manufactured with spacer bars made from lower-conductivity materials like stainless steel, instead of the more commonly used aluminium. This can also help to significantly improve the IGU thermal performance.

Solar Heat Gain and Low-e Coatings

Low-emissivity (low-e) coatings are used on the glass to reduce radiative heat transfer across the sealed insulating glass unit. Low-e coatings consist of a layer of metal only a few microns thick that are spectrally selective but visually clear, in order to minimize the amount of ultraviolet and infrared light that can pass through the glass. The low-e coating improves the thermal performance of the IGU, and impacts the SHGC for controlling solar heat gain. The selection of the type and placement of the low-e coating must be balanced with the desire to allow passive solar heat gain in during the cold periods, as well as the appearance of the window and the resulting light it lets in. This selection should be made with input from the energy modeller, and must be taken into account in the building energy model.

In high-performance buildings, the windows can be used to allow solar heat gain during the winter, without leading to overheating in warmer periods. However, in larger, multi-unit buildings, it is generally not possible to use orientation-specific design to take advantage of passive solar heat gain. In most cases it is beneficial to use low-e coatings that will achieve medium to low SHGC (0.40–0.20) for occupant comfort or to reduce the need for cooling.

Insulating Glazing Unit Components

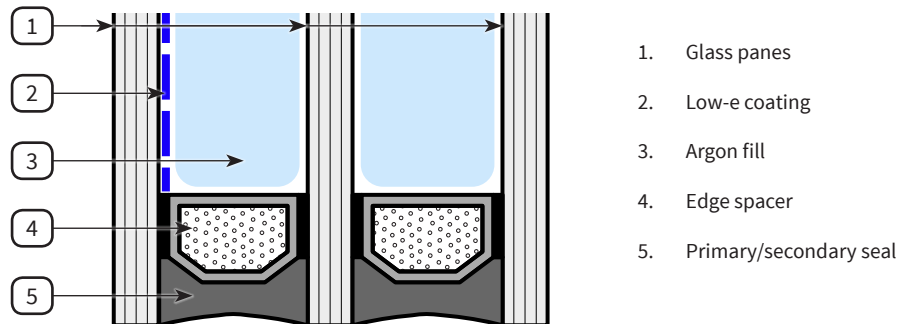

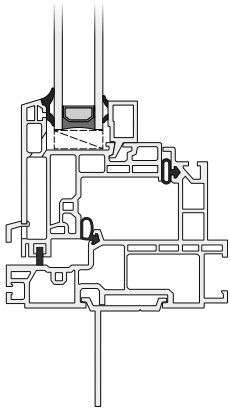

Flange window

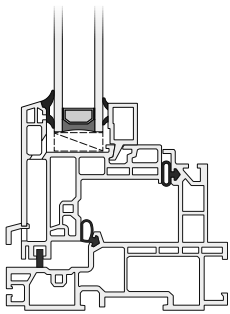

Non-Flange window

Flange vs. Non-Flange

The installation method for all fenestration types should include an interior air seal with backer rod and sealant, even if the window includes a flange for structural attachment to the wall. While this flange can be taped at the top and side edges to improve water-shedding characteristics, it should not be used as the air seal.

Window Installation Method

Beyond the energy performance of the window itself, the installation arrangement in the wall has the biggest impact on the in-service window thermal performance. While thermal bridging at the window perimeter may not be directly accounted for in energy modelling software, it should be included as a reduction in the overall assembly R-value. For more guidance on accounting for assembly thermal bridging in energy models, refer to the City of Vancouver Energy Modelling Guidelines document (see [Additional Resources on page 147](#)), which is directly referenced in the Step Code. Only the Passive House Planning Package (PHPP) software has built-in metrics for accounting for thermal bridging due to the window installation method.

The in-service thermal performance of the window can be improved by insulating at jamb and head between the window frame and the rough opening using moisture-tolerant batt insulation. If thicker exterior insulation is used, consider over-insulating the outside edge of the frame with rigid insulation. Where possible, attach metal drip flashings and closure flashings to the outside portions of the frame, rather than setting them into the rough opening and risking significant thermal bridging. The perimeter flanges on flange windows provide an attachment substrate for these components and may make installation simpler.

The installation method also impacts the in-service airtightness around the perimeter of the fenestration product at the rough opening. Backer rod and sealant should always be installed between the interior perimeter of the frame and the sheathing membrane air barrier in the rough opening. Refer to the illustrations in [Section 07 Airtightness on page 91](#) and [Section 09 Details on page 115](#) for further guidance.

Window Details Wayfinder

Flange Window
[Detail 01 on page 116](#)
 Non-Flange Window
[Detail 02 on page 117](#)
[Detail 03 on page 118](#)
[Detail 04 on page 119](#)

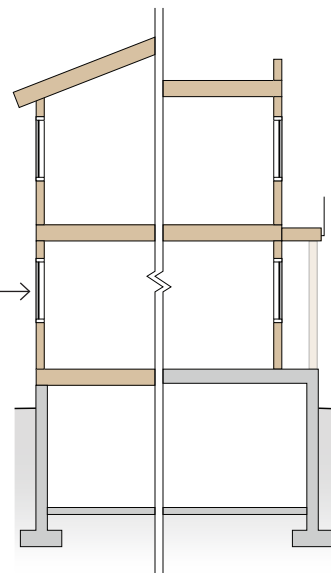

Glazed Doors

Entry doors made in the same manner as windows, with larger portions of glazing inside a perimeter frame, are subject to the same energy performance requirements and rating standards as windows. Door side-lites are also considered as windows. Opaque doors with small portions of decorative glazing set into the door slab are not considered as glazing.

Opaque Doors

While the energy performance metrics for opaque doors exclude the solar heat gain coefficient, the door U-value and air leakage rate still apply. These energy performance characteristics must be accounted for in the energy modelling. Opaque doors made from wood, fibreglass and even metal can be constructed with foam fill to achieve high R-values. Entry doors are often more difficult to make airtight because they use lower sills with less contact area for perimeter gaskets. As there are generally fewer entry doors than windows in dwelling units, the energy performance of the opaque doors have a lower impact on the overall building energy performance. However, if needed, some high-performance door products use thick door slabs and multiple perimeter gaskets to achieve high R-values and excellent airtightness.

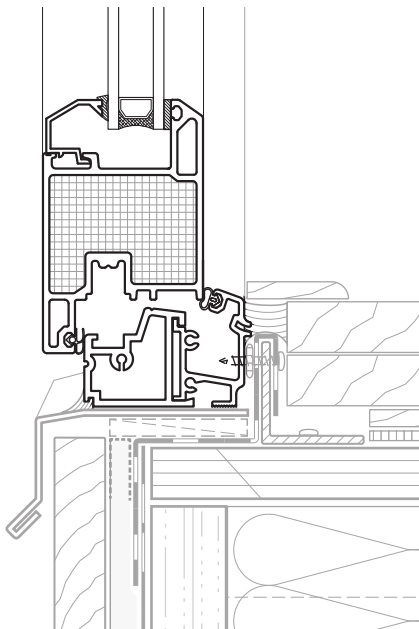

Glazed entry door

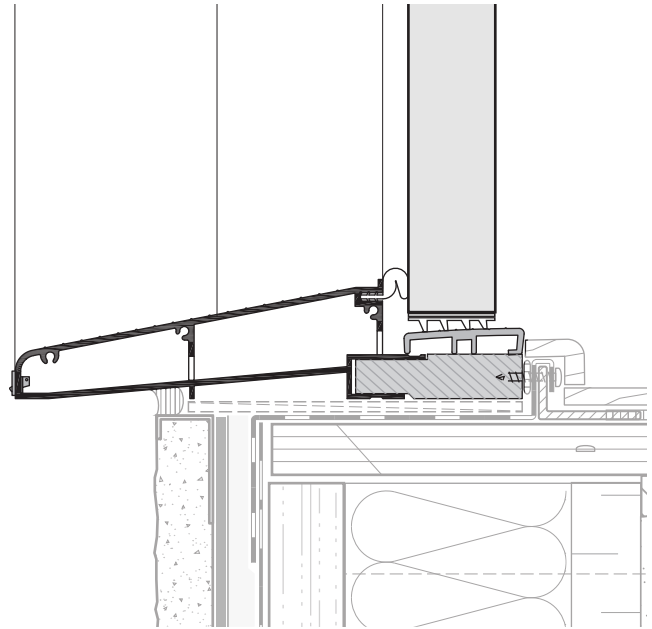

Opaque entry door



07 Airtightness

Illustrated Guide

See the *Illustrated Guide - Achieving Airtight Buildings*, published by BC Housing, for more information on designing, building, and testing for whole-building airtightness.

Section Includes:

- Air Barrier as a System 91
- Air Barrier Requirements 92
- Air Barrier Strategies 93
- Detailing 99
- Air Barrier Transitions 102

Air Barrier as a System

An effective air barrier consists of a continuous system of materials (building wrap, membranes, etc.), components (doors, windows, etc.) and accessories (tapes, sealants, etc.).

The air barrier elements must be airtight individually and when used together as a system.

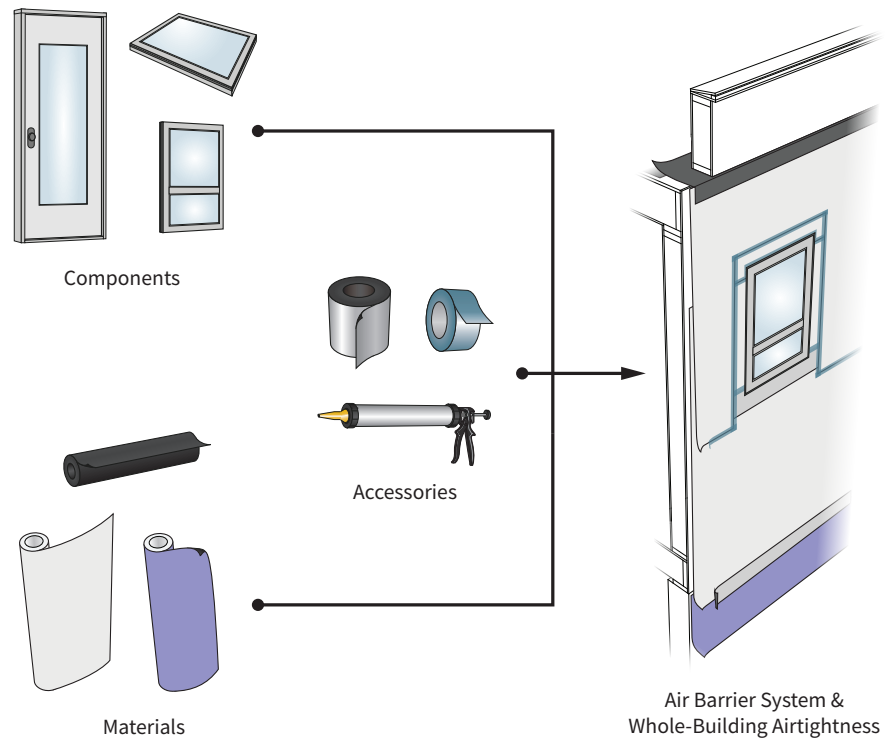

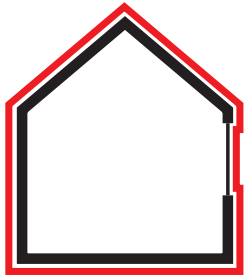

Continuous

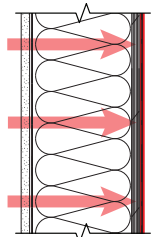

Air Impermeable

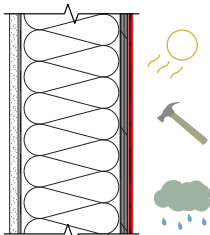

Durable

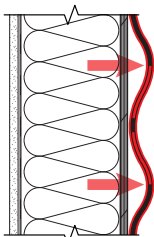

Stiff

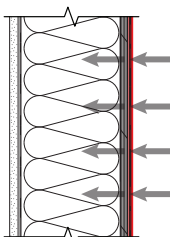

Strong

Air Barrier Requirements

The design of an effective air barrier system requires materials, components, and accessories that can be combined to control air leakage. While relatively straightforward to achieve in the field of an assembly, ensuring continuity of the air barrier at interfaces and penetrations of the building enclosure is more challenging and hence critical to performance. An effective air barrier should have the following features:

Air Impermeability

All materials, components, and accessories making up the air barrier system must be able to prevent airflow. This is typically defined in industry standards referenced by the building code as an air permeability less than $0.02 \text{ L/s}\cdot\text{m}^2$ (0.004 cfm/ft^2) at 75 Pa.

Continuity

Continuity is the single most important criteria for an effective air barrier system, but also one of the most challenging. Designers and contractors must ensure continuity of the air barrier around penetrations, transitions, and interfaces in the enclosure. The system must completely enclose the conditioned space.

Durability

The air barrier system must be designed to last for the entire service life of the building or of the materials that cover it. To do so, it may be necessary to regularly maintain sealants or other components of the system, which should be designed to be easily accessible. The system should resist mechanical forces, UV exposure, moisture, chemicals, and other contaminants, throughout its expected service life. Interfaces in particular should be designed to be resilient and able to accommodate expected deflections, for example at floor slabs.

The durability of the enclosure system itself is important. Air barrier selection must account for vapour movement within the system and exterior moisture loads. Exterior vapour-impermeable membranes may risk trapping moisture inside the assembly. Air barrier materials used as the water-resistive barrier must be appropriately installed to provide the necessary protection from moisture loads. See [Section 06 Assemblies on page 53](#) and for more guidance on assembly durability and vapour/moisture management.

Strength and Stiffness

From construction to occupancy, the air barrier system must resist forces acting on it. The design should account for mechanical forces created by wind and stack effect pressures and allow for dimensional changes in the structure caused by thermal expansion and moisture absorption. A combination of fasteners, tapes, sealants, strapping, exterior insulation, or fully adhered products may be used to achieve this requirement.



Air Barrier Performance

The key advantage of exterior air barrier approaches is that interior penetrations for services like plumbing and electrical, and disruptions at floors, stairs, and interior walls, do not affect the continuity of the air barrier. Whole-building air leakage tests have shown that exterior air barrier approaches consistently perform better than interior air barrier approaches, especially for large buildings.

On-site Qualitative Testing

Besides the quantitative airtightness testing required by the Step Code, qualitative testing using theatrical fog and/or thermal imaging can also be used during construction to verify building airtightness at interfaces and penetrations. Refer to the *Illustrated Guide - Achieving Airtight Buildings*, published by BC Housing, for more information.

Air Barrier Strategies

Air barrier systems are usually two conventional types: exterior air barrier systems, with the primary airtight elements placed at the exterior side of the enclosure, and interior air barrier systems, with the primary airtight elements installed at the interior side of the enclosure. Within these systems there are various approaches and components used to achieve the air barrier.

Exterior air barrier approaches use an airtight layer, usually a dedicated membrane, installed over the exterior face of the building structure, and made continuous with tapes, membranes, and sealants over joints, transitions and penetrations. The interior approaches use an airtight layer applied from the interior of the enclosure, interfacing with the various interior elements, transitions, and penetrations. In general, the exterior approach is simpler, because it does not interface with numerous interior elements like framing or service penetrations for electrical and plumbing. Also, because the components of the exterior air barrier are often also used as the water-resistive barrier (for example spun-bonded polyolefin on walls), the effort and care required to achieve a continuous layer to resist moisture intrusion also contributes to the overall continuity of the air barrier.

However, the exterior air barrier still must interface with interruptions at the outside of the building, such as balconies, canopies, and some service penetrations. The design and detailing should account for these challenges.

Interior approaches, often using polyethylene sheet or interior finishes as the primary airtight element, must account for the numerous interruptions at the interior. The detailing and effort required to make the interior surfaces airtight across these elements is generally more difficult compared with using an exterior approach, though this approach can still be used to achieve an effective air barrier.

In some cases, such as with deep stud-insulated walls, both an interior air barrier and an exterior air barrier should be installed to reduce potential air movement into the assembly and improve the overall assembly airtightness. This double air barrier approach reduces the risk of moist air moving through the assembly and condensing within the wall cavity. For further durability of the assembly, it should be designed to allow for drying in case of accidental wetting. This is commonly achieved using a vapor permeable water-resistive membrane as the exterior air barrier material.

This guide shows a variety of air barrier strategies across different building enclosure assemblies. See [Section 09 Details on page 115](#) for more details on the various air barrier approaches that can be used, and the steps required to maintain airtightness across all transitions and penetrations.



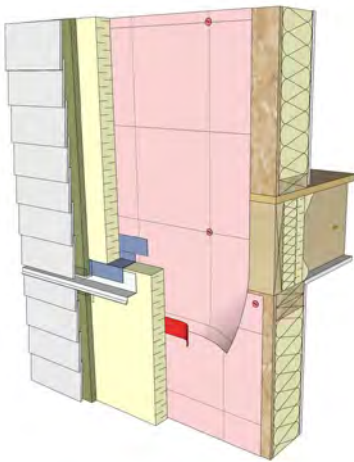

Sheathing Membrane

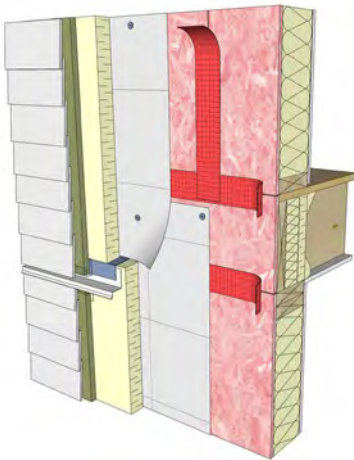

Sealed Exterior Sheathing

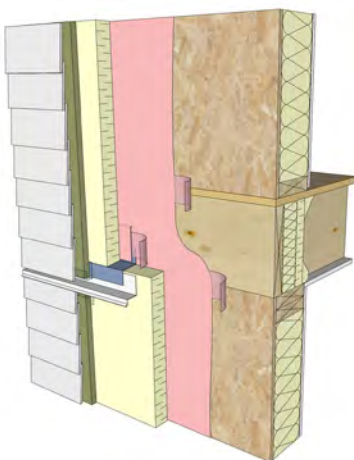

Liquid Applied Membrane

Above-Grade Wall Exterior Air Barrier Systems

Sheathing Membrane Approach

Mechanically fastened systems use an airtight sheathing membrane, also referred to as house wrap, attached to the exterior sheathing with fasteners and washers. Joints, penetrations, and laps are made airtight using sealant, tape, and self-adhered sheathing membrane strips. This is a commonly used exterior air barrier system for low-rise wood-frame construction. Care should be taken to ensure the sheathing membrane is adequately attached to the building during construction and it should be supported by strapping or cladding to avoid damage. This approach is not typically appropriate for taller buildings or those with higher design wind loads.

Self-adhered sheathing membranes rely on the adhesion to the substrate as well as the adhesion at membrane laps. The membrane should be installed so that it is fully adhered to the substrate upon initial installation. The membrane should also be installed onto a suitable dry substrate that provides continuous backing.

The sheathing membrane is also usually used as the water-resistive barrier, and must be installed and detailed as such.

Sealed Exterior Sheathing Approach

The exterior sheathing, when sealed at joints and interfaces, can also act as the primary air barrier element. This approach uses the exterior sheathing together with either sealant, liquid applied sheathing membrane, strips of membrane, or sheathing tape to create a continuous air barrier at the sheathing joints. A sheathing membrane is often required with this approach to provide the water-resistive barrier.

Liquid Applied Membrane

Exterior liquid applied membranes share many of the advantages of self-adhered membranes and are especially useful for complex detailing. Liquid applied membranes rely upon a supporting substrate to provide a continuous backing in order to achieve an airtight barrier. Joints typically require specific detailing considerations and often incorporate membrane reinforcement. The substrate and weather conditions can have a significant impact on curing time and adhesion. The manufacturer's instructions should be strictly followed.

Air Barrier Materials

The red and pink materials shown highlight the components of the air barrier system, and are not intended to represent any specific brands or products.



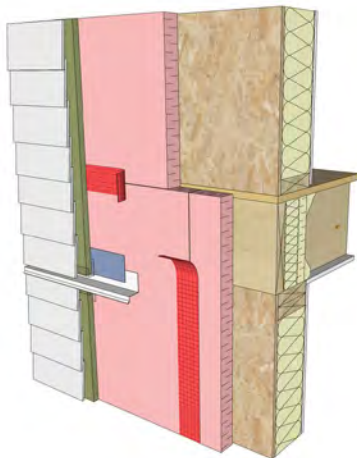

Sealed Exterior Insulation

Sealed Exterior Insulation Approach

Taped exterior foam sheathing can be used as an effective air barrier, and is often supplied as a proprietary system of materials and components. The airtight foam is used as the primary air barrier element, and tape, gaskets and sealant is used to transition between insulation boards and across other enclosure elements. Extruded polystyrene (XPS) is the insulation type most often used in this system, though other foams, including spray foam, can be used. Note that in this approach, the taped exterior insulation is also generally used as the water-resistive material.

The permeability of the foam insulation is of particular importance with respect to the drying capacity of the wall assembly. An assembly with exterior foam insulation and an interior vapour control layer may benefit from using a relatively more permeable interior vapour retarder such as a smart vapour retarder or vapour barrier paint.

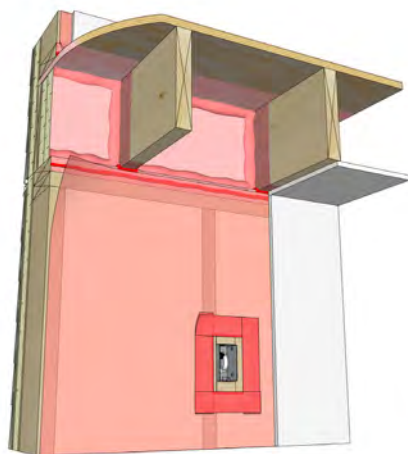

Sealed Polyethylene

Above-Grade Wall Interior Air Barrier Systems

Sealed Polyethylene Approach

In this system, polyethylene sheets are sealed to the interior framing to form the air barrier. All joints in the polyethylene are also sealed and clamped between the framing and the interior finish (or service cavity framing). Locations where interior finishes are not normally provided require specific measures to ensure the polyethylene is supported.

The various interfaces between the exterior walls and interior elements such as staircases, interior walls, floor framing and service penetrations make the sealed polyethylene approach a difficult air barrier system to implement successfully. Therefore, it is not recommended for buildings where high-performance airtightness is required, unless a service cavity is also installed.

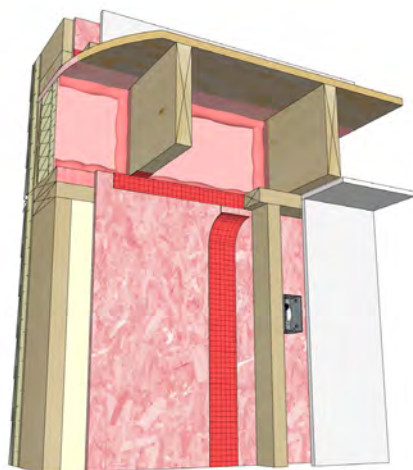

Sealed Interior Sheathing

Sealed Interior Sheathing Approach (with Service Cavity)

This approach uses an interior layer of sheathing as the primary air barrier element. The sheathing joints are sealed with tape or membrane strips, and the perimeter is set onto gaskets or sealant on the wall framing. Penetrations through the air barrier can be limited by using a service wall framed inside the sheathing, where electrical and plumbing services can be run.



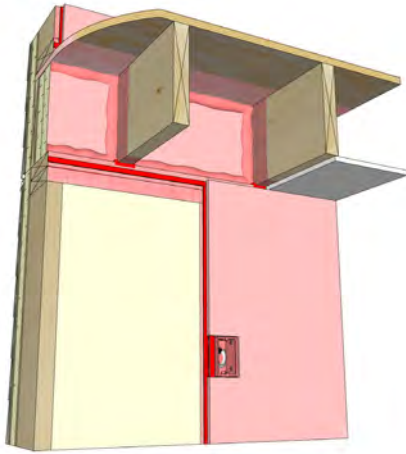

Airtight Drywall

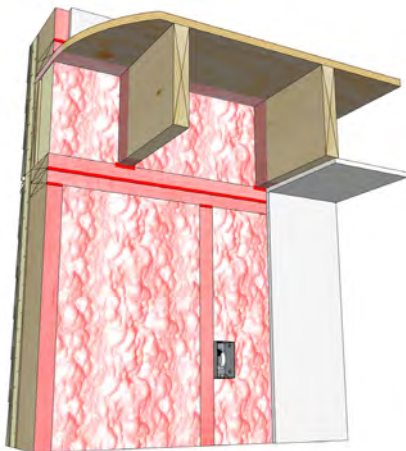

Interior Spray Foam

Airtight Drywall Approach

In the airtight drywall approach, the interior gypsum board and framing members provide the air barrier. Continuity between different materials is created with sealants or gaskets. Special attention is required to seal penetrations in the gypsum board at electrical fixtures and other services, as well as the intersection of partition walls with exterior walls and the ceiling. The various interfaces at the exterior walls make the airtight drywall approach a potentially difficult air barrier system to implement. This system is sometimes used in wood-frame construction and is often used as the air barrier approach for interior compartmentalization.

Interior Spray Foam Approach

In this approach, interior spray foam is used as the primary airtight element around the framing and service components inside the exterior wall assembly. Closed-cell spray foam should be used as it is airtight and specifically permitted in the BCBC for Part 9 construction. In this approach, all wall cavities are filled with insulation, and framing members are sealed at joints and junctions. The airtightness of this assembly relies on both continuous and uniform spray foam insulation, as well as sealing of framing members with high-quality construction sealant like silicone or urethane. Note that the building code requires that a qualified professional install closed-cell (two-part) spray foam, following the correct mixing and installation procedures.

Panelized Approaches

Panelized systems are becoming more common as a means of accelerating construction and allow manufacturing to occur off site. This approach often uses conventional wood-frame wall assemblies with an exterior air barrier, that are made continuous between panels on site using membranes, tape and sealant. This approach requires careful coordination to allow the sealing of the air barrier at all panel perimeter edges, prior to final completion of the cladding or exterior insulation on site. If this coordination is achieved, these types of panelized systems can be among the most airtight air barrier approaches.

Proprietary panelized and modular systems that use specialized concealed gaskets or sealant at perimeter edges to achieve air barrier continuity are also becoming more common. However, since it is difficult to visually confirm that a continuous air barrier has been achieved with these types of systems, special care during installation is required, and qualitative airtightness testing during construction is recommended.



Roof Air Barrier Systems

Sheathing Membrane Approach

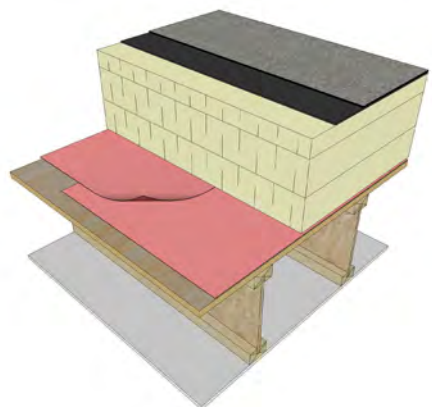

Sheathing Membrane

This approach uses a self-adhered roof sheathing membrane as the primary air barrier element. Self-adhered sheathing membranes rely on adhesion to both the substrate and at membrane laps. The membrane should be installed so that it is fully adhered to the substrate upon initial installation. The membrane should also be installed onto a suitable dry substrate that provides continuous backing. Penetrations through the sheathing and membrane should be limited by using dedicated service openings that can be appropriately sealed. The air barrier should be reviewed for continuity before the remaining roof assembly components are installed over it. The sheathing membrane can also be used as a temporary moisture management system on the roof before the full assembly is installed.

Sealed Polyethylene Approach

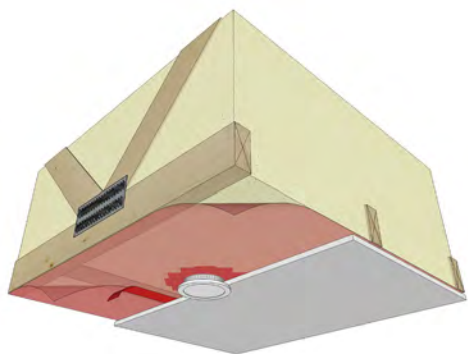

Sealed Polyethylene

In this approach, polyethylene sheets are sealed to the interior framing to form the air barrier. All joints in the polyethylene are also sealed and clamped between the framing and the interior finish (or service cavity). Locations where interior finishes are not normally provided, like at double-stud partition walls, require specific measures to ensure the polyethylene is supported.

The various interfaces between the roof and interior elements such as partition walls, and the many penetrations at the ceiling, make the sealed polyethylene approach a difficult air barrier system to implement successfully. Therefore, it is not recommended for buildings where high-performance airtightness is required, unless a service cavity is also installed. This approach is best suited to attic-insulated roof assemblies where the exterior side of the air barrier can be reviewed and detailed from within the attic before insulation is placed.

Sealed Interior Sheathing Approach (with Service Cavity)

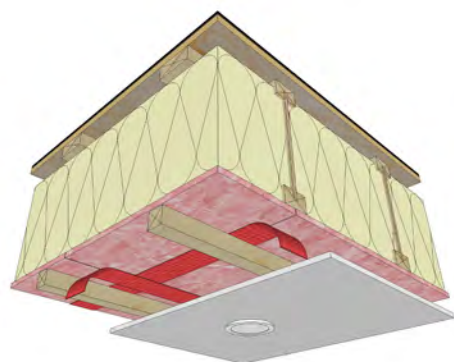

Sealed Interior Sheathing

This approach uses an interior layer of sheathing as the primary air barrier element at the roof. The sheathing joints are sealed with tape or membrane strips, and the perimeter is set onto gaskets or sealant on the roof framing. Penetrations through the air barrier can be limited by using a service cavity framed inside the sheathing, where electrical and plumbing services can be run. This approach is a good option for flat roofs with insulation in the framing cavity, since the air barrier must be made fully airtight from the interior side of the enclosure, and the stiff sheathing substrate allows for robust detailing. The service cavity is an important component and should be included wherever possible.



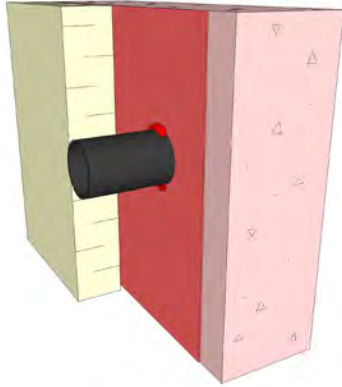

Concrete Air Barrier with Membrane

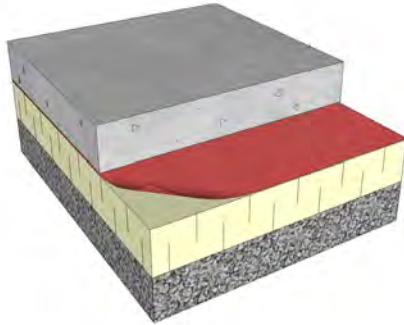

Sealed Membrane

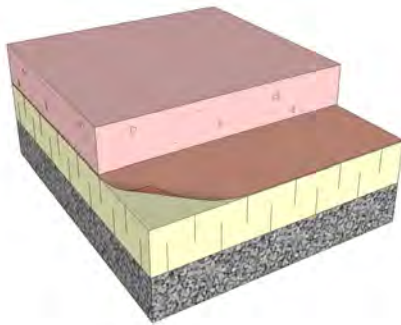

Sealed Membrane and Floor Slab

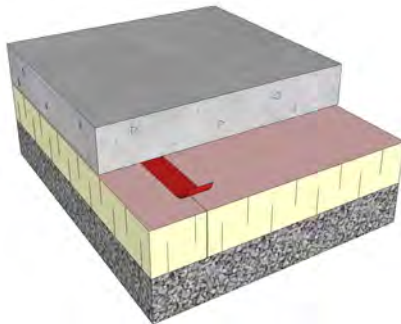

Taped Insulation

Concrete and Below-Grade Assemblies

For many concrete assemblies, the concrete itself is often the primary air barrier. However, a dedicated air barrier material in addition to the concrete can provide improved performance, because cracking of the concrete, especially in floor slabs, poses a risk to long-term air barrier performance. Penetrations and intersections may also be easier to make airtight when there is a dedicated air barrier membrane to transition to. However, detailing requirements at the top and bottom of the wall may be simpler if the concrete is used as the primary air barrier, rather than a membrane.

Sealed Membrane Approach

This approach uses a dedicated sheet membrane as the air barrier, with joints, penetrations, and edges sealed with sealant or tape. It is better to use a minimum 15-mil thick polyethylene or high-density polyethylene sheet to minimize the potential damage that may be caused during construction and from the concrete slab. At the perimeter walls, sealant may be required directly between the slab and the foundation wall. In these cases, the slab acts as part of the air barrier system, but the continuity of the air barrier should still be maintained at the membrane beneath it.

Sealed Insulation Board Approach

In this approach, the insulation board beneath the slab is used as the primary air barrier element. The joints and penetrations in the boards are sealed with tape, and the perimeter is sealed to the foundation wall. This system must use airtight insulation boards like extruded polystyrene.



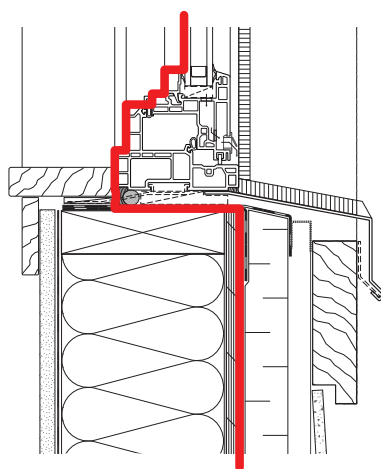
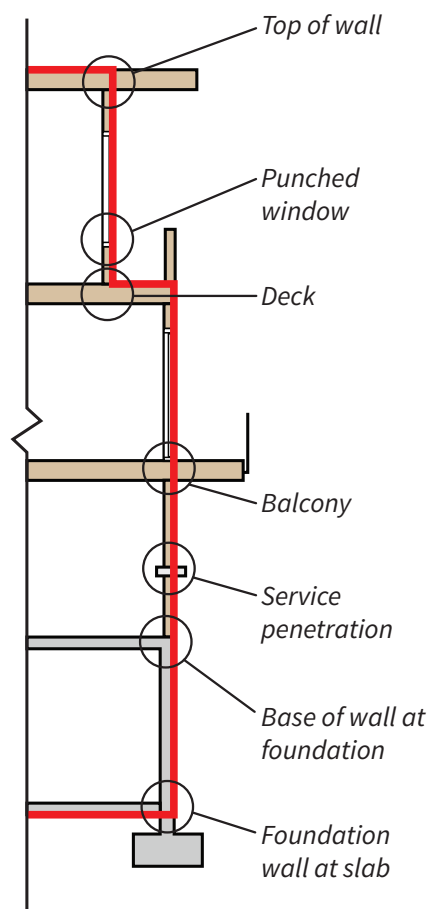

Example Air Barrier Lines of Continuity

Detailing

The most important aspect of designing an airtight enclosure is detailing the interfaces and penetrations, because this is where discontinuities are most likely to occur. While the individual air barrier materials and components provide control of air movement for each individual assembly, how and where each assembly intersects and the continuity of the air barrier across these joints should be the focus of the detailing work. Whether at the base of wall, windows, service penetrations, roof-to-wall interface, or countless other detail locations, the details should provide a clear indication of the air barrier continuity across the building enclosure.

A best practice design technique for ensuring continuity of the air barrier is to draw a continuous line around the enclosed space. This can help to identify the air barrier on building plans, sections, and details. The line should continue around the entire enclosure and connect back to itself with no discontinuities. It should be possible to trace the air barrier without, as it were, lifting one's pen off the paper. The same concept applies to individual detail drawings as well. A detail should be prepared for all air barrier interface locations, clearly showing how continuity is maintained. Reviewing these transitions early on and collaborating with the affected trades will allow locations with constructability or sequencing issues to be identified and help determine if a revised detail is necessary.

Assemblies with interior air barriers in particular must account for all the potential interruptions and interfaces at the interior face of the building. Details for these locations should include all necessary components and products, and basic installation measures, to provide a continuous air barrier across all elements of the assembly. For example, air sealing using spray foam at the interior framed cavity must be combined with sealant across all joints in the wood framing such as studs and built-up plates, no matter how tightly fitted they are.

See, [Section 09 Details on page 115](#) and [Additional Resources on page 147](#) for more guidance on detailing at transitions and penetrations in the air barrier.



Early Detailing

Detailing is an integral part of the overall design process even in early stages of design development. It should be used to inform and develop the overall design while there is still flexibility in placement and configuration of elements. Leaving discussion of details until later in the design process could lead to complicated or costly corrective measures.

Sequencing

Details should consider construction sequencing and overall robustness. For example, wherever possible, air barrier transitions in wood-frame construction should be designed to allow complete construction of the primary wood framing before installation of the air barrier components. This way the work of different trades can be separated, and the air barrier installation can be more easily coordinated.

Consider installing exterior elements (not integral to the enclosure or structure) using standoffs and intermittent attachment points. This can allow the air barrier to only be interrupted with point penetrations, rather than extended interfaces like at balconies or roofs.

3D Sequence Drawings

Detailing may require three-dimensional drawings to convey air barrier transitions, both for design development and as part of the construction documents, to convey all aspects of an air barrier interface. The most critical locations are often difficult to illustrate on 2D drawings alone. Further air barrier design and detailing guidance is available in:

- [Section 06 Assemblies on page 53](#) and [Section 09 Details on page 115](#)
- *Building Enclosure Design Guide*, BC Housing
- *Guide for Designing Energy-Efficient Building Enclosures*, FPInnovations
- See [Additional Resources on page 147](#)

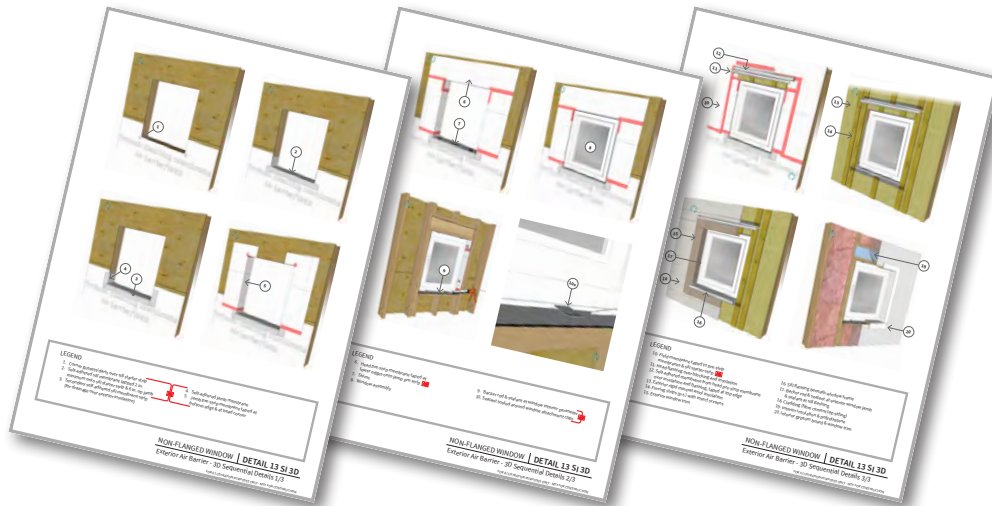

Example 3D Window Installation Sequence Drawings



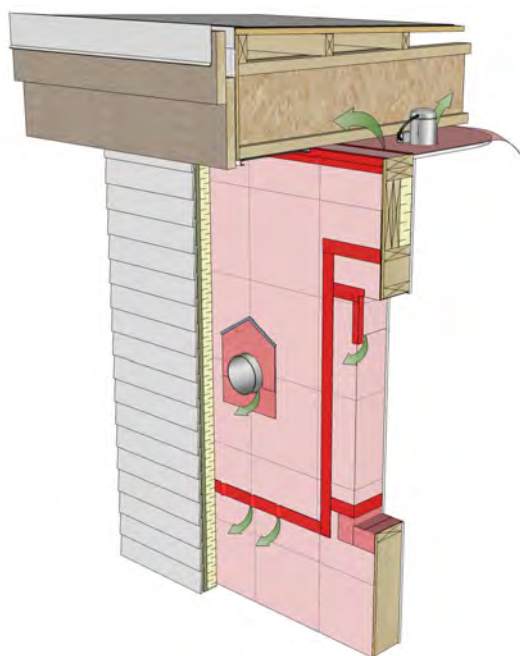

Common Deficiencies

Common Deficiencies

Common deficiencies and challenging areas for exterior air barrier installation can occur at all areas of the air barrier system. The integrity of the air barrier relies upon the quality and completeness of the installation work. Some common air barrier deficiencies and likely deficiency locations include:

- › **Structural and service penetrations using sealant and membranes**
- › **Wrinkled/fishmouth/incomplete membrane laps**
- › **Roof-to-wall and other interfaces with various transition materials**
- › **Roof/ceiling penetrations**
- › **Window membrane and perimeter sealing**
- › **Above-grade to below-grade transitions**
- › **Complex building forms and enclosure shapes such as fin walls and projections**

These deficiencies can be avoided by using comprehensive detailing at the design stage, and employing proper quality control and assurance measures during construction.

On-site quality control of air barrier installation is a complex process. It is fundamentally important to achieving an airtight building and requires substantial oversight. Although the design documents may include details and instruction for all air barrier interfaces and penetrations, the builder is ultimately responsible for ensuring all aspects of the system are installed and complete. Site mock-ups serve to demonstrate the air barrier installation processes and regular reviews of the air barrier installation promotes consistent and complete work as part of the ongoing quality control process. The building enclosure consultant should be notified with sufficient time to review the air barrier, especially at critical details, throughout the construction process. However, the consultant will not always be present and there is a risk of discontinuities being missed or created in the air barrier throughout the construction process.

A successful approach to mitigate this risk is to designate an “air boss”, who is a member of the construction team responsible specifically for the air barrier. This person should be appropriately trained on and knowledgeable of air barrier strategies, the specific air barrier systems being used on the project, and requirements for building airtightness testing. For more information on successful implementation of a high-performance air barrier system, refer to the *Illustrated Guide - Achieving Airtight Buildings* (see [Additional Resources on page 147](#)).



Air Barrier Transitions

The details included in [Section 09 Details on page 115](#) of this guide use various high-performance approaches to the common transitions found in wood-frame residential construction. They represent constructible strategies that allow straightforward sequencing, while providing for continuity of the air barrier across the enclosure transition. However, the air barrier transition detailing can be modified as needed based on the materials and skills available, and the construction sequencing. This section outlines several options for common transition details, including those used in the details in [Section 09 Details on page 115](#).

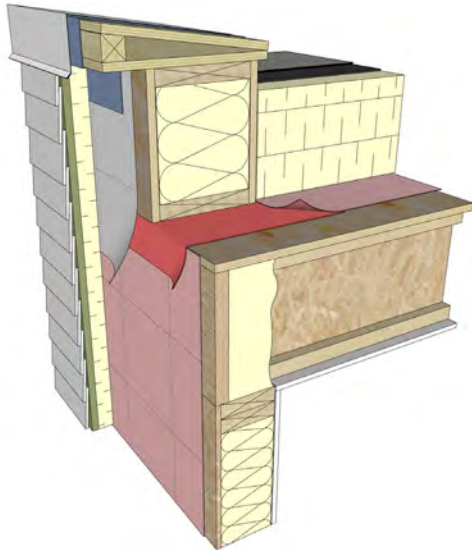

Parapet Pre-Strip

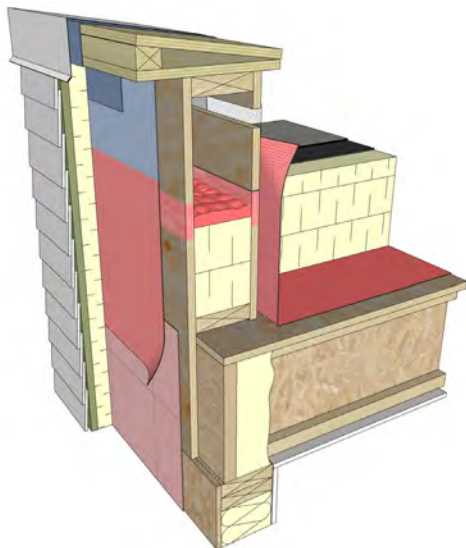

Parapet Spray Foam

Roof-to-Wall Transition

The intersection between the roof and the above-grade wall can be one of the most difficult transitions, on a building. It is also one of the most vulnerable areas to air leakage if not done properly.

Parapet Pre-Strip

It can be difficult to transition the roof sheathing membrane air barrier to the wall exterior air barrier if there is a framed parapet in place at the roof perimeter. The pre-strip method uses an air barrier membrane strip beneath the parapet framing. The membrane provides a continuous air barrier uninterrupted by framing. This approach relies on the parapet being framed separately from the wall and roof framing. Any penetrations at the base of the parapet, including structural ties, must be carefully sealed to avoid air leakage into the parapet. The pre-strip method provides the simplest air barrier transition at the low-slope roof-to-wall detail.

Parapet Spray Foam

Where the parapet must be framed in conjunction with the roof framing, the barrier may have to pass through the parapet framing cavity. Closed-cell spray foam can be installed in each stud cavity between the two interior faces of the parapet sheathing. The sheathing and self-adhered membranes on either side of the parapet become part of the air barrier transition. Note this configuration should include parapet venting where possible. This approach requires coordination between the framing work and insulation, because the insulation fill and spray foam must be installed before the upper portion of the roof-side parapet sheathing is installed. The parapet spray foam approach is not a simple air barrier transition and can be difficult to implement.



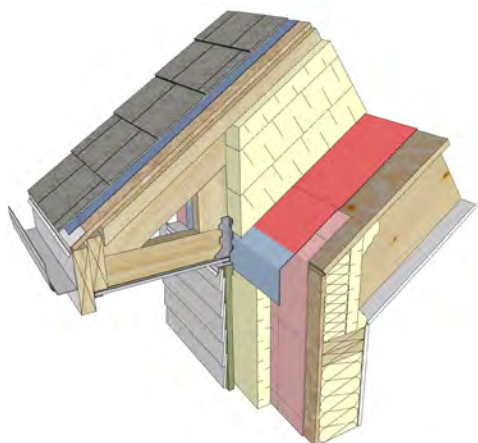

Sheathing Membrane

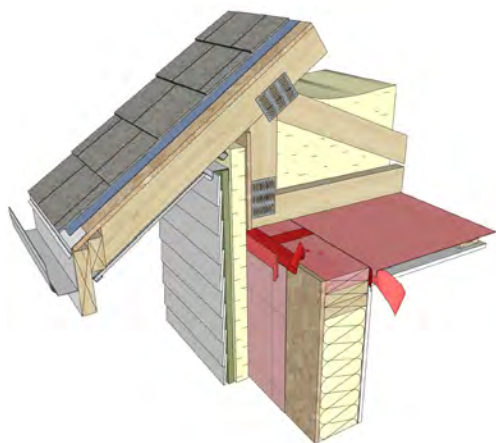

Taped Top Plate

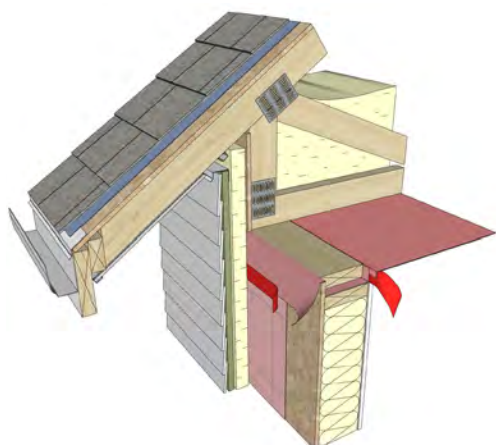

Top Plate Pre-Strip

Sheathing Membrane

Similar to the parapet pre-strip method, this approach uses a sheathing membrane lapped directly over the wall sheathing membrane, with no interruptions from the roof framing. The roof insulation and a secondary roof sheathing layer should be installed above this membrane to allow for venting and overhang framing, although it is possible to use interior insulation in the roof joist cavity if the assembly is unvented. This “exterior” roof air barrier approach allows for pass-through beneath the roof insulation and framing.

Taped Top Plate

The air barrier transition between the ceiling air barrier and the exterior wall air barrier is achieved with tape at the exterior and interior perimeter and at all joints and intersections in the top plate. This approach creates a continuous air barrier at the top plate, and does not require any per-stripping or sealant work while the wall is framed. Although the tape must be applied before the roof framing is placed, it allows for separation between the framing work and the air barrier transition work. This simplifies the task and allows for better quality control of the air barrier system. This approach also removes the need for polyethylene pre-stripping in the interior framed walls, since the top plates are all made airtight, and the interior ceiling air barrier can be sealed directly to the top plate interior tape. Note that where an interior taped sheathing wall air barrier is used, a pre-strip of sheathing should be installed at the interior top edge of the wall framing and the top edge should be taped to the top plate, to simplify air barrier continuity. The taped top plate approach can be used with all interior roof air barrier approaches, including OSB sheathing. The tape used in this method should be high-performance sheathing tape with acrylic adhesive, with the ability to adhere well, even to wet wood.

Top Plate Pre-Strip

This approach uses strips of air barrier membrane, sandwiched between the two top plates, as the air barrier transition through the wall framing. The membrane is sealed at the interior to the ceiling air barrier and at the exterior to the wall air barrier. This method is not ideal as it relies on correct membrane lapping and sealing as part of the wall framing, and produces a “blind” seal between the two top plates. It is therefore less reliable compared to the taped top plate method. The pre-strip membrane should be a vapour-open air barrier material at the exterior wall top plates, and polyethylene at the interior wall top plates.

Note that the membrane is sandwiched between the top plates to avoid having a slippery membrane on surfaces that will likely require access for placing the roof framing. If a pre-strip membrane is used over-top of the top plates, it should include a non-slip surface.



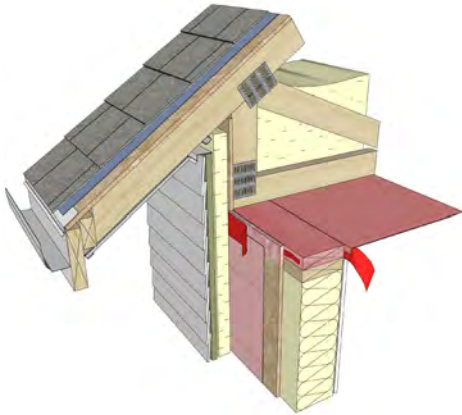

Sheathing Sealant

Sheathing Sealant

Sealant is applied between the interior face of the exterior sheathing and the wall top plate. Similar to the taped top plate approach, the wall top plate is used as the primary air barrier component across the top of the wall, though it relies on a blind seal behind the sheathing. Continuity is difficult to confirm, since the air barrier must transition from the ceiling membrane to the wall top plate, through the top plate itself, and through the sealant and sheathing. All joints in the top plate and sheathing top edge should also be sealed. This method is not ideal as it relies on correct sealant application as part of the wall framing, and produces a “blind” seal in the system. It is therefore less reliable compared to the taped top plate method.

Windows and Doors

Air barrier continuity between the wall assembly and windows or doors is an important aspect of whole-building airtightness. Even while the wall membrane and the window or door products are airtight individually, their connection must be carefully considered. This is especially important because the transition may also be highly exposed to exterior moisture, and must be both airtight and watertight to avoid water ingress and damage.

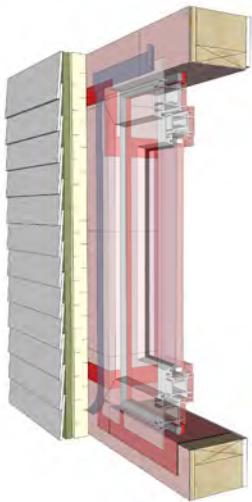

Backer Rod and Sealant

Backer Rod and Sealant

This method relies on a sealant bead between the window or door frame and the membrane in the rough opening. This is the most common air barrier transition approach for punched windows. If the window or door frame includes a perimeter flange, it should be used only as the mounting system, and not included as part the air barrier transition. Standard sheathing tape can be installed only at the jambs and head to provide additional water-shedding ability.

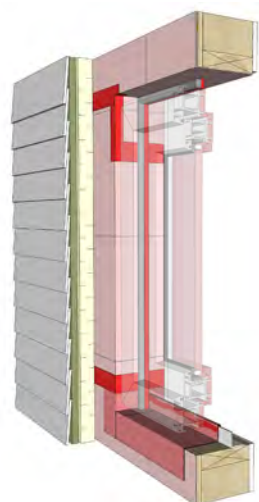

Back-dam

Back-dam

This method uses a continuous metal angle at the window sill, with the sill membrane installed over it, and the window or door frame set into sealant. The sill angle provides a continuous substrate for the air barrier and water-resistive barrier transition, raised above the level where moisture may be present, as well as a solid component for mounting the window or door at the sill. This approach can be used around the entire perimeter of the rough opening if needed. It is generally a considered a more robust installation method due to the increased moisture protection of the continuous angle. This method should be used in highly exposed areas, and at door sills.



Above-Grade Wall to Foundation Wall

The air barrier transition between the above-grade wall and the foundation wall generally relies on the foundation wall concrete as the primary air barrier component below-grade, unless a dedicated air barrier is used (such as with ICF walls). The above-grade wall air barrier can transition to the concrete in various ways depending on the building code requirements and the above-grade air barrier system used.

Taped Membrane

This method uses transition tape applied between the bottom of the wall framing and the top of the concrete wall. The transition tape provides a surface to tape the sheathing membrane to using standard sheathing tape. This transition tape could be a self-adhered sheathing membrane, or a high-performance tape with acrylic adhesive. This is a recommended air barrier transition approach, since it is simple and robust. Note that the base of wall flashing is installed separately from the air barrier transition membrane and tape. This allows for a continuous air barrier without interruption or complication from the flashing.

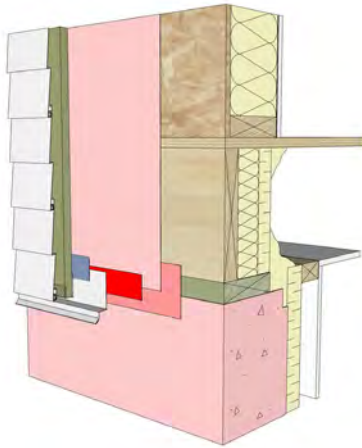

Taped Membrane

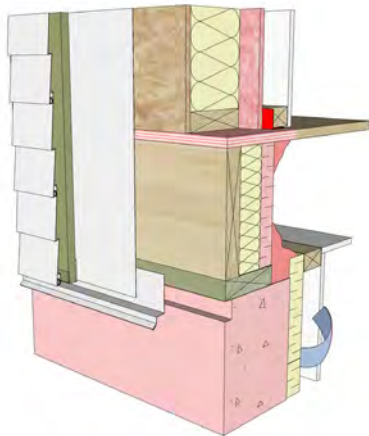

Interior Spray Foam

Spray Foam

For interior air barrier approaches, this method provides a transition between the underside of the flooring and the top side of the foundation wall using closed-cell spray foam between the floor joists. While other approaches shown in this guide include this spray foam at the floor joists for insulation and vapour retarder continuity, it can only be considered an effective air barrier transition in this scenario when there is a dedicated interior air barrier such as sealed polyethylene or sheathing. This approach allows the framing and exterior membrane work to proceed apart from the interior air barrier components.

Membrane Pre-strip

This approach is suited to below-grade enclosure assemblies that do not have exposed concrete that can be sealed to, such as ICF walls. The membrane pre-strip is used to transfer the air barrier from the exterior sheathing membrane to the interior side of the foundation wall, beneath the floor/wall framing. It provides a dedicated surface for sealing on both sides of the assembly. This approach relies on coordination during the time between the foundation work and the framing. The membrane must be installed with all edges lapped and taped, and penetrations such as anchor bolts sealed, before the sill plate is installed.

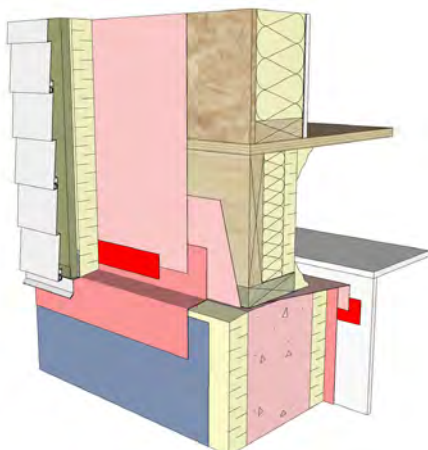

Membrane Pre-strip



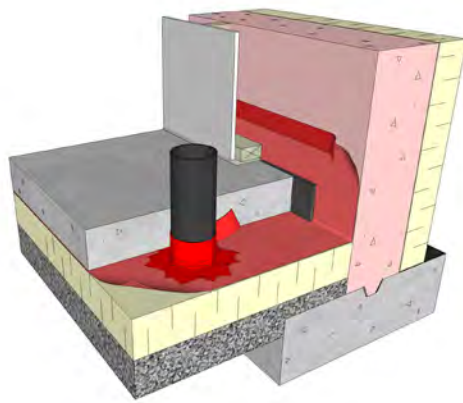

Taped Membrane

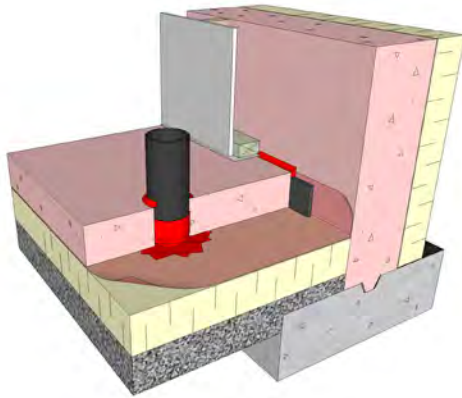

Slab Sealant

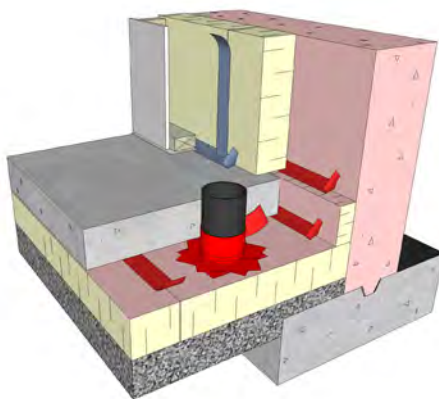

Taped Insulation

Foundation Wall to Slab-on-Grade

The air barrier transition at the below-grade wall to slab-on-grade assembly generally relies on the foundation wall concrete as the primary air barrier component. The slab air barrier can be sealed to it in various ways depending on the building code requirements and the air barrier system used.

Taped or Sealed Membrane

The membrane beneath the slab is sealed to the foundation wall using high-performance tape or sealant. A direct connection between the dedicated slab air barrier membrane and the foundation wall concrete is the preferred approach. The tape or sealant should be installed above the top of the slab so that it is visible even after the slab is poured. Penetrations in the membrane should also be taped or sealed directly to the membrane before the concrete slab is placed.

Slab Sealant

This method relies on a sealant bead to provide the air barrier continuity between the slab and foundation wall. In this case, the slab may be considered part of the floor air barrier system, but a membrane beneath the slab should also be used. The membrane can be terminated at the same position up the foundation wall as the top of the slab and the sealant bead, to provide continuity between it and the wall.

Taped Insulation

Where the insulation beneath the slab is used as the air barrier, it can be sealed directly to the foundation wall with tape. If interior insulation boards are used at the foundation wall, the joints in the boards should be taped to limit the potential for interior air and moisture to reach the concrete wall. However, the concrete foundation is still considered the primary air barrier element.

Refer to [Section 09 Details on page 115](#) for more guidance on the various important air barrier transitions across the enclosure.



08 Mechanical Equipment and Systems

Section Includes:

- Overview107
- Heating and Cooling109
- Ventilation111
- Domestic Hot Water113
- Auxiliary Equipment114

Equipment Operating Efficiencies

Equipment operating efficiency measures the efficiency at which input energy is converted to useful output energy. Besides efficiencies, other factors such as equipment capacities and distribution should be evaluated when designing the mechanical systems and choosing equipment.

Overview

The mechanical equipment and systems of a building can have a large impact on its energy efficiency and overall energy consumption, and hence have a large impact on the Building Equipment and Systems metrics. The required capacity of the mechanical equipment and systems will vary with the performance of the enclosure, and vice versa. This section briefly describes examples of mechanical equipment and systems that may be used to reach various steps of the Step Code. This section is not intended to limit the use of any mechanical system or specific product. Both Part 9 and Part 3 buildings can use a wide variety of options, as long as the systems are modelled for compliance with Step Code metric targets. Furthermore, the operating efficiencies that can be achieved with the different systems are not the sole indicator of their appropriateness for use in high-performance buildings.

House as a System

As discussed in [Section 04 Principles of High-Performance Buildings on page 25](#), it is imperative to understand that building components, mechanical equipment, and occupants work as a system. When incorporating an enclosure-first approach the thermal performance of a building is designed to reduce thermal losses and thermal gains throughout the year, which reduces the required capacity of heating and cooling equipment. Furthermore, the mechanical systems can be more easily controlled where the losses are reduced, and the systems can be optimized to further reduce the energy use of the building.

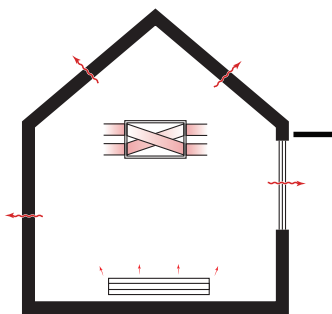

An example solution: a house with a high-performance enclosure where an HRV provides healthy indoor air quality while recovering heat from the exhaust air. Makeup heat is provided by electric baseboards.

For example, with an airtight enclosure the code-required minimum ventilation levels is more easily accounted for and controlled since indirect ventilation through building air leakage is reduced. Where an energy-efficient ventilation system like a heat recovery ventilator (HRV) is used (see [page 112](#)), the energy load required to heat the incoming outdoor ventilation air can be minimized. Here the enclosure and the mechanical equipment in combination provide energy-efficient building operation.



Industry Best Practice

Both the Thermal Environmental Comfort Association (TECA) and the Heating, Refrigeration and Air Conditioning Institute of Canada (HRAI) provide guidelines and courses for the design and installation of heating, cooling and ventilation systems. More information is available at www.teca.com and www.hrai.ca.

TECA and HRAI have explicit methodologies with worksheets and software for heat load calculations that should be used for heating and cooling system sizing to ensure that load estimates are completed appropriately.

Sizing of Equipment

Heat loss and heat gain calculations are the basis by which the mechanical heating and cooling systems are selected. In effect, all sources of heat loss (building enclosure, ventilation, etc.) are combined with sources of heat gain (occupants, appliances, heat recovery, etc.) in order to estimate the needed output of the heating and cooling system. For heating, this is related to the TEDI metric.

The required capacity and efficiency of Domestic Hot Water (DHW) and Heating Ventilation and Air Conditioning (HVAC) systems depends on building size, end use, fuel choice, and energy target. The energy model used to evaluate a building's performance may also be used to size mechanical equipment and systems. As with the building enclosure, there are many possible paths and system choices that will enable the achievement of each Step in the Step Code.

Part 3 buildings will require professional mechanical design of all systems in the building, including the domestic hot water and the ventilation system. Large buildings can produce complex scenarios due to more significant internal heat gains from occupants and equipment, unique heating and ventilation requirements based on each individual suite, and the possible need for large central equipment that serves the entire building.

Installation and Commissioning

Careful attention should be paid to the design, installation, and commissioning of mechanical systems. Installation considerations are specific to the equipment type and should always follow manufacturer specifications and industry best practice guidelines. Post-installation commissioning will ensure the mechanical systems are functioning to their specified efficiencies.

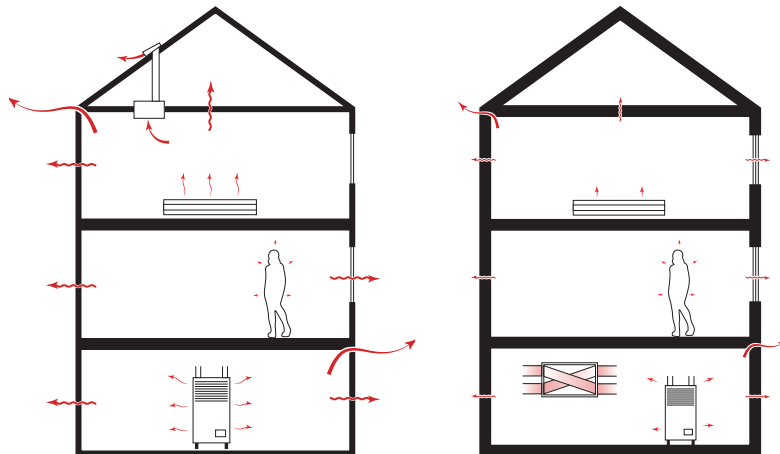

Mechanical equipment sizing is based on the sources of heat loss (building enclosure, ventilation, etc.), the sources of heat gain (occupants, appliances, etc.), and the presence of heat recovery (HRV, DWHR, etc.)



Heating and Cooling

The energy used for heating and cooling of buildings can be reduced in two ways. One way is by increasing the thermal performance of the building enclosure – an enclosure-first approach – and the other is by choosing more energy-efficient mechanical equipment. To reach the Lower Steps of the Step Code, either or both approaches can result in compliance. For the Upper Steps, both approaches are likely necessary. Gas furnaces, baseboards, heat pumps, and hydronic systems can all be used to meet the Step Code performance targets.

Gas Furnace

Gas furnaces are common heating equipment for Part 9 buildings. The code requires high-efficiency (condensing) furnaces with efficiencies of at least 92%. The efficiencies used in the Energy Step Code 2018 Metrics Research Full Report were 92% and 96%. However, furnaces currently available on the market reach up to 98.5% efficiency.

High-efficiency condensing furnaces use two heat exchangers to extract heat energy from the combustion of fossil fuel (e.g. natural gas, propane, oil) to heat air. The incoming air is generally both recirculating (return) air from the building, and makeup ventilation air. The energy demand of the furnace is based on the amount of air that must be heated to condition the home, and the temperature difference between the incoming air and the temperature it must be heated up to. The furnace energy demand can be optimized by increasing the temperature of the (cold) ventilation air entering the system using heat recovery, or by using a dedicated ventilation system that uses heat recovery.

Baseboard (Electric)

Electric baseboards are common heating systems both for Part 9 buildings and Part 3 buildings, and have an efficiency of 100%. Electric baseboards generate heat by electric resistance in a heating element. The heat is then distributed by radiating fins. They can be operated individually, which allows for easier operation in buildings with multiple zones.

Buildings that use electric baseboard heating systems must provide ventilation through a dedicated system, because baseboards do not provide ventilation air.

Operating Costs

While each heating and cooling system offers different benefits, reduced operating costs for the end user may be worth considering. This cost optimization approach is referred to as net present value (NPV). For more information on the study of cost optimization for buildings aiming to meet the Step Code, refer to the *Energy Step Code 2018 Metrics Research Full Report* (see [Additional Resources on page 147](#)).

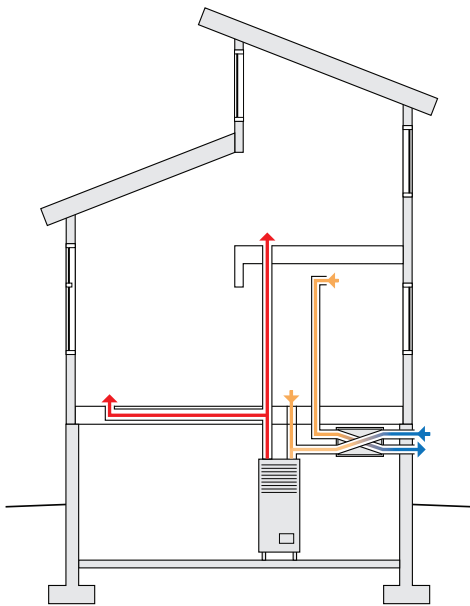

Furnace combined with a heat recovery ventilator to improve energy efficiency

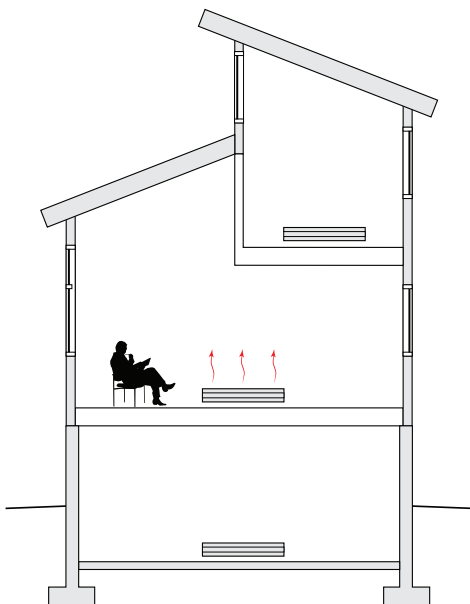

Electric baseboard heaters can be controlled individually



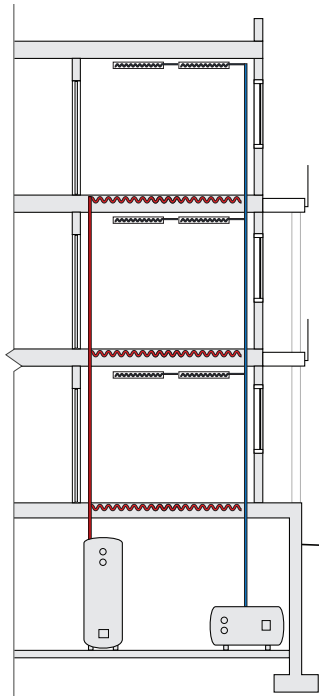

Hydronic system using a boiler and a chiller to provide both heating and cooling

Hydronic Systems (Baseboards, Fan-Coils, Radiant Floors)

Hydronic systems can be used for heating, cooling, or both. A fluid is heated and/or cooled centrally, then piped through a building to terminal units. The terminal units are commonly hydronic baseboards, fan-coil units, or radiant floors. There are many options for the central heating and cooling plants, each with different efficiencies and benefits. For example, the central heating plant can be a natural gas boiler coupled with a chiller (see left) if both heating and cooling are desired. Boilers typically use combustion to heat the liquid, while chillers generally function through a refrigeration cycle to chill liquid. Alternatively, heat pumps may be used for low-temperature radiant systems, both for heating and for cooling. The domestic hot water system can also be coupled with a hydronic system.

Low-temperature radiant systems can be used in buildings with high thermal performance. These systems require lower water temperatures throughout the system and thus are paired well with heat pump water heaters, which have lower maximum water heating capacity than traditional boilers. Note that radiant systems may increase the risk of overheating without proper controls and commissioning. This increased risk is most relevant for buildings with very high-performance enclosures. Note that it is important to properly commission all systems in any installation.

Heat Pump

A heat pump is a device that circulates refrigerant that absorbs and releases heat through evaporation and condensing of the refrigerant as it travels between and the indoors and outdoors. It operates in a similar way to a traditional air conditioner, but its function can be reversed to provide heating as well as cooling. Heat pumps can operate at much higher efficiencies than other typical residential heating and cooling options, in some cases over 300% efficiency. Heat pump efficiencies are measured in Coefficient of Performance (COP), where a 300% efficiency would be denoted COP 3.0.

The most common type of heat pumps are air-source; however, ground-source heat pumps are also available. Air-source heat pumps extract heat from the outside air during the heating season, and extract heat from the indoor air in the cooling season. Ductless mini-split systems are air-source heat pumps which are commonly used to control temperatures in individual rooms or spaces by heating or cooling air (air-to-air system). Larger heat pumps are generally used as part of a central heating or cooling system in larger buildings. Cold Climate Air Source Heat Pumps are specially designed for cold climates, and can extract heat from the air down to -35°C at about the same efficiency as electric baseboard heaters.

Ground-source heat pumps draw heat from the ground or water in the heating season, and returns heat back into the ground in the cooling season. Ground source heat pumps are also known as geothermal, geoexchange and earth-energy systems, and are often combined with a central distribution system.

Sewage heat recovery is another type of heat pump system that extracts heat from waste water. These systems can be used for either domestic hot water or space heating.

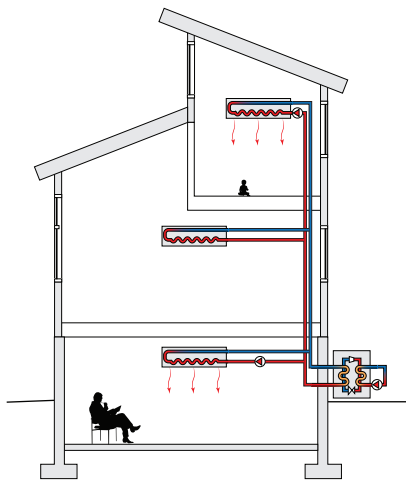

Air-to-air heat pump system with multiple interior fan-units



Ventilation

With increased building airtightness comes the need for sufficient mechanical ventilation to ensure a healthy indoor environment for building occupants. A well-designed and properly installed system will provide the right amount of ventilation and can be used to save energy.

In Part 9 buildings, various ventilation systems can be used, but each type must provide direct ventilation to each bedroom and living space. Natural ventilation is permitted during the non-heating season using operable windows, but a mechanical ventilation system must be used during the heating season.

Dedicated Air Inlet and Exhaust Fan

A dedicated fresh air inlet, combined with a central ducted heating system and an exhaust fan, can serve as an effective basic ventilation strategy, especially for Part 9 buildings. This strategy uses the ducts for the heating system and a continuously running circulation fan to supply fresh air to all living areas, even if the heating system is not running. At the same time, a continuously running exhaust fan, such as a bathroom fan, extracts stale indoor air. High-efficiency fans (≤ 0.2 W/cfm) can be used to minimize energy consumption of the fan operation itself, though the energy required to condition the ventilation air is often a greater energy load for the building. In this system, the ventilation air must be conditioned by the building heating equipment, and the greater the temperature difference between the outdoors and indoors, the greater the energy demand for this process.

Makeup Air Systems

Makeup air systems use a central supply fan to provide ventilation air throughout a building. These ventilation systems are commonly used in large buildings and consist of a central makeup air unit (MAU) with ducting supplied to all spaces or units in the building. The MAU also conditions cold air to comfortable levels before it is supplied to the building. Typically, these units are gas fired and heat the air through a heat exchanger. High-efficiency (condensing) MAUs have efficiencies above 90%. Alternatively, air-source heat pumps can be used for both heating and cooling and can offer efficiencies above 300%. A makeup air unit can also be combined with an HRV to improve its efficiency.

The BC Building Code requires direct ventilation to each living space, thus indirect corridor ventilation strategies such as pressurized corridors are not acceptable. The central makeup air system must be installed with ducts that supply the ventilation air directly to residential units.

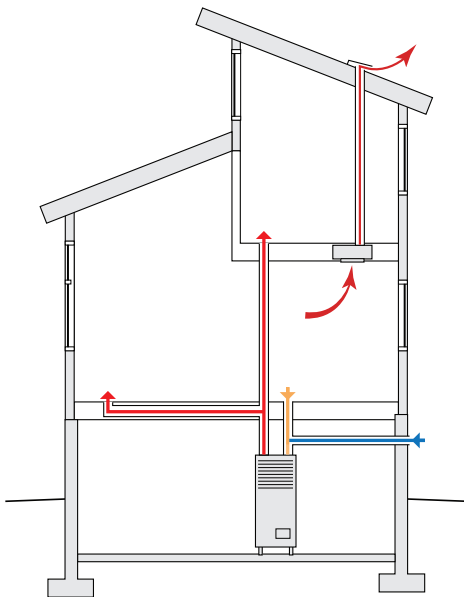

Ventilation with a continuously running exhaust fan and a dedicated air inlet

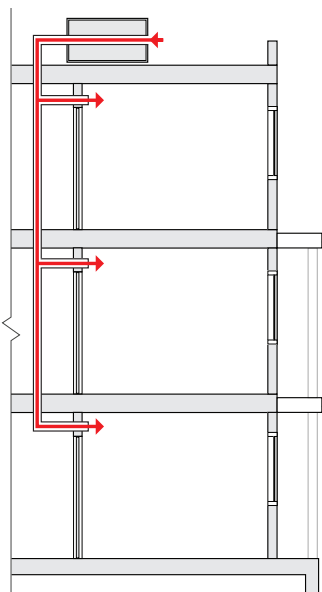

Central MAU in a multi-unit residential building



Ventilation Heat Recovery

A heat recovery ventilator (HRV) or an energy recovery ventilator (ERV) can be used to recover energy from exhaust air. These devices use a passive heat exchanger to transfer heat between outgoing exhaust and incoming supply air streams within the ventilation units. Supply air is typically ducted directly to each living area, and exhaust air from bathrooms and kitchens. In heating climates, HRVs and ERVs are primarily used to recover heat from the exhaust air to temper the supply air, but they can also work in reverse in the cooling season. The heat transfer effectiveness typically ranges from 60% to 85%.

HRV and ERV systems provide continuous, balanced, energy-efficient, and comfortable year-round ventilation to homes. Additional benefits come from air filters within the units, which filter out pollutants and pollen. A single unit is typically used for single family homes. In multi-unit buildings, HRVs and ERVs can be installed in each suite, or may be located centrally and ducted through a central ventilation system.

HRVs and ERVs use a similar system, but ERVs also transfer humidity between the supply and exhaust air streams. A specialized heat exchanger, called the enthalpy core, allows both heat and moisture transfer between air streams, without cross-contamination. The ERV can be used to lower the humidity of the incoming ventilation air during warm humid periods, by transferring moisture from the supply air to the outgoing exhaust air, assuming it has lower humidity. It can also be used to transfer the humidity of outgoing air to incoming supply air during cold and dry periods.

ERVs are generally more common in severe climates where humidity levels reach upper and lower extremes. The moisture transfer is intended to improve occupant comfort by maintaining comfortable ambient moisture levels. It can also reduce the need for air conditioning or humidifiers, which contribute to the overall energy use of the building.

HRVs generate condensation which should be plumbed to drain. ERVs do not generate condensation and do not need to be plumbed to drain.

Note that Central Recirculating Ventilators (CRVs) use a similar ventilation arrangement as HRVs and ERVs, but without the efficiency of heat recovery and instead using recirculation and direct fresh air intake.

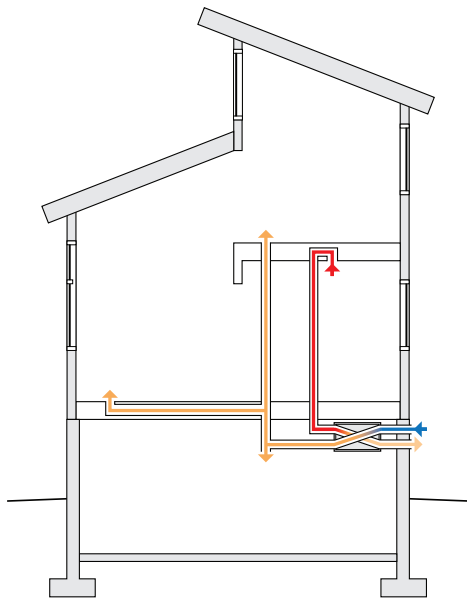

Ventilation with a heat recovery and ducting throughout

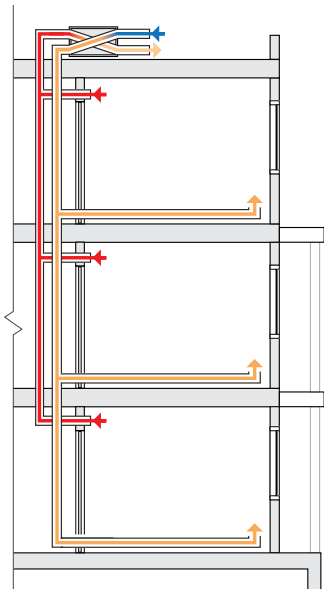

Central ventilation with heat recovery in a multi-unit residential building

Noise Reduction

Ventilation system design and installation should include noise reduction strategies to provide a quiet system. Noise from a continuously running fan, or the airflow through the ducting, may be disturbing to the building occupants.



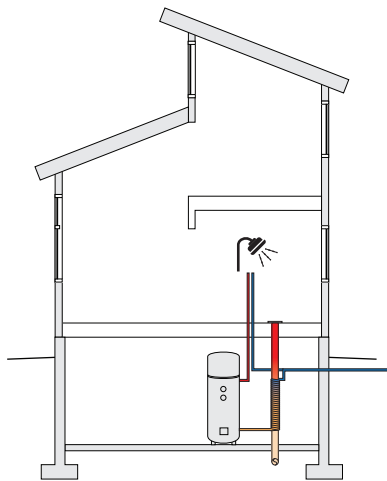

Tank-type water heater with drain water heat recovery

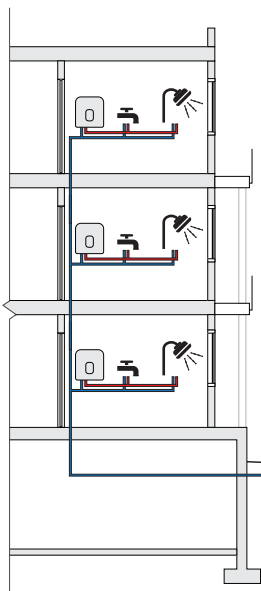

In-suite tankless hot water heaters

Sewage Heat Recovery

Sewage heat recovery uses heat pump technology to extract heat from waste water. This system is mainly used in larger residential buildings.

Domestic Hot Water

The heating of domestic hot water (DHW) can account for 15-35% of a building's energy use, depending on the building type. DHW energy use may be reduced by selecting energy-efficient equipment and systems as well as drain water heat recovery. Incorporating low-flow fixtures (shower heads and faucets) is a great way to reduce hot water usage, but is only accounted for in Part 3 energy modelling.

Tank-Type

Conventional DHW heaters typically heat the water with a gas boiler or electric coil, then store the heated water in an insulated tank sized to the demand of the building. It is recommended to have at least a condensing efficiency natural gas boiler (90% or higher). For higher efficiencies, air-source heat pump hot water tanks can be incorporated (>300%). Furthermore, hot water tanks may be heated by site-generated energy through heat pumps or solar thermal systems.

The domestic hot water distribution pipes may be designed with recirculation and heat tracing to maintain water temperatures throughout the building. This approach is not very energy-efficient, and a more efficient way to provide domestic hot water in multi-residential buildings is by equipping each unit with their own water heater.

Tankless Water Heaters (On Demand/Instantaneous)

Tankless water heaters can be used as the domestic hot water heating system for houses as well as in-suite in multi-residential buildings. This type of water heater is also referred to as 'on-demand' and 'instantaneous' as the water is heated as it is used. Tankless heaters are generally condensing efficiency natural gas. For larger households, multiple tankless water heaters may be required to meet the hot water demand for multiple uses simultaneously, for example running the dishwasher and taking a shower at the same time. Tankless water heaters work well in individual suites of multi-unit residential buildings, as they take up minimal room, allow the occupant direct control of their hot water usage, and reduce the need for substantial plumbing installations throughout the building.

Drain Water Heat Recovery

Another way to reduce DHW energy use is by recovering heat from the waste water. This is an effective heat recovery strategy in residential buildings due to their high shower usage. Drain water heat recovery typically works through the installation of a copper section of pipe installed in line with the main domestic drain pipe (that drains from showers), with another copper pipe heat exchanger wound tightly around it. The copper heat exchanger is connected to the supply line of the water heater. It extracts heat from the drain water running along the walls of the drain pipe and raises the temperature of the incoming supply water.



Part 9 Mechanical Energy Use Intensity

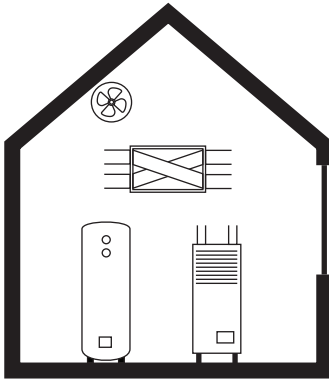

- › Space heating
- › Space cooling
- › Service water heating equipment
- › Auxiliary HVAC equipment

Part 3 Total Energy Use Intensity

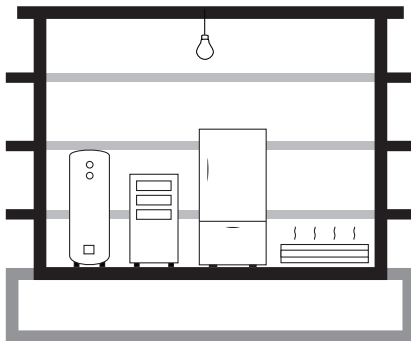

- › Space heating
- › Space cooling
- › Service water heating equipment
- › Auxiliary HVAC equipment
- › Miscellaneous receptacles and appliances
- › Lighting

Auxiliary Equipment

The Mechanical Energy Use Intensity for Part 9 buildings (MEUI, see [page 14](#)) and the Total Energy Use Intensity for Part 3 buildings (TEUI, see [page 14](#)) each require that the auxiliary HVAC equipment be accounted for in the overall energy use. Auxiliary HVAC equipment generally includes fans, humidifiers and other devices that are not directly accounted for in the heating, cooling, ventilation, and domestic hot water energy use. All HVAC auxiliary mechanical equipment like fans should be high-efficiency to help reach TEUI targets.

Additional Loads Included in Part 3 TEUI Metric

Note that receptacles, appliance, and lighting load must also be accounted for in the TEUI. Energy-efficient products should be used wherever possible to help meet the TEUI targets. This includes LED lighting and high-efficiency appliances.



09 Details

Section Includes:

- **Windows** 116
 - Detail 01** Flange Window in Stud-Insulated Wall 116
 - Detail 02** Non-Flange Window in Split-Insulated Wall with Thin Exterior Insulation 117
 - Detail 03** Non-Flange Window in Split-Insulated Wall with Thick Exterior Insulation 118
 - Detail 04** Non-Flange Window in Deep Stud-Insulated Wall with Service Cavity 119
- **Sloped Roofs** 120
 - Detail 05** Transition Between Stud-Insulated Wall and Insulated Attic Sloped Roof 120
 - Detail 06** Transition Between Split-Insulated Wall with Thin Exterior Insulation and Insulated Attic Sloped Roof 121
 - Detail 07** Transition Between Split-Insulated Wall with Thick Exterior Insulation and Insulated Attic Sloped Roof 122
 - Detail 08** Transition Between Deep Stud-Insulated Wall and Insulated Attic Sloped Roof 123
 - Detail 09** Transition Between Stud-Insulated Wall and Joist-Insulated Sloped Roof 124
 - Detail 10** Transition Between Split-Insulated Wall with Thin Exterior Insulation and Joist-Insulated Sloped Roof 125
 - Detail 11** Transition Between Deep Stud-Insulated Wall and Joist-Insulated Sloped Roof 126
 - Detail 12** Transition Between Split-Insulated Wall with Thick Exterior Insulation and Exterior-Insulated Roof 127
- **Low-Slope Roofs** 128
 - Detail 13** Transition Between Stud-Insulated Wall and Joist-Insulated Vented Flat Roof with Parapet 128
 - Detail 14** Transition Between Stud-Insulated Wall and Exterior-Insulated Conventional Flat Roof with Parapet 129
 - Detail 15** Transition Between Split-Insulated Wall and Exterior-Insulated Conventional Flat Roof with Parapet 130
 - Detail 16** Transition Between Stud-Insulated Wall and Joist-Insulated Vented Flat Roof with Overhang 131
- **Rim Joist** 132
 - Detail 17** Stud-Insulated Wall at Rim Joist 132
 - Detail 18** Split-Insulated Wall with Thin Exterior Insulation at Rim Joist 133
 - Detail 19** Split-Insulated Wall with Thick Exterior Insulation at Rim Joist 134
 - Detail 20** Deep Stud-Insulated Wall at Rim Joist 135
- **Rim Joist at Supported Balcony** 136
 - Detail 21** Stud-Insulated Wall at Supported Balcony 136
 - Detail 22** Split-Insulated Wall with Thin Exterior Insulation at Supported Balcony 137
 - Detail 23** Deep Stud Wall at Supported Balcony 138
 - Detail 24** Transition Between Stud-Insulated Wall and Interior-Insulated Foundation Wall 139
- **Below-Grade** 140
 - Detail 25** Transition Between Split-Insulated Wall with Thin Exterior Insulation and ICF Foundation Wall 140
 - Detail 26** Transition Between Split-Insulated Wall with Thick Exterior Insulation and Exterior-Insulated Foundation Wall 141
 - Detail 27** Transition Between Deep Stud-Insulated Wall and Interior-Insulated Foundation Wall 142
 - Detail 28** Transition Between Exterior-Insulated Foundation Wall and Exterior-Insulated Slab 143
 - Detail 29** Transition Between Interior-Insulated Foundation Wall and Exterior-Insulated Slab 144
 - Detail 30** Transition between ICF Foundation Wall and Exterior-Insulated Slab 145

Air Barrier Materials

The red and pink materials shown highlight the components of the air barrier system, and are not intended to represent any specific brands or products.

Detail 01 Flange Window in Stud-Insulated Wall

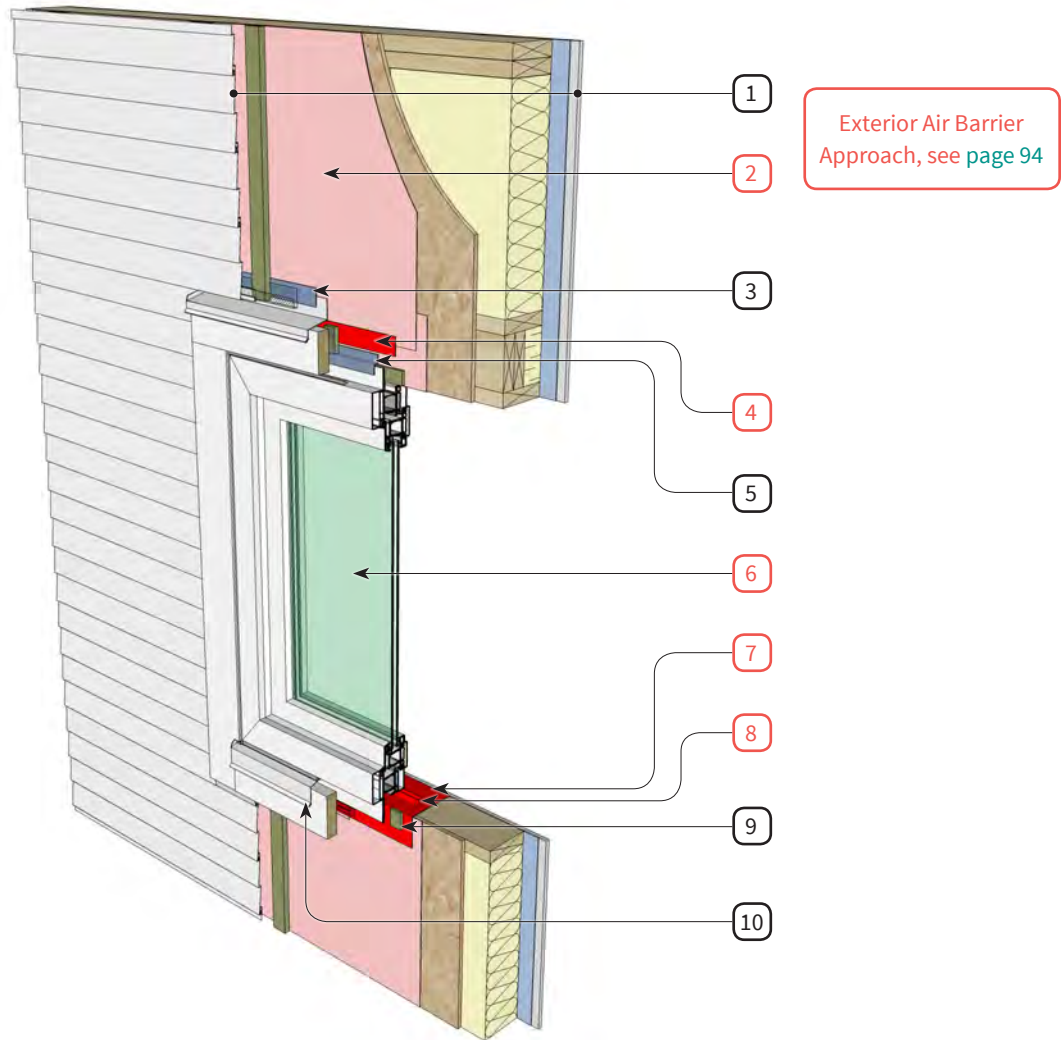

1. Stud-insulated wall assembly, see [page 56](#)
2. Vapour-permeable sheathing membrane (AB)
3. Head flashing with sheathing tape over top edge
4. Sheathing tape at all laps in sheathing membrane (AB)
5. Sheathing tape over window head and jamb flange
6. Window assembly sealed to air barrier with backer rod and sealant, see [page 104](#) (AB)
7. Self-adhered impermeable sill membrane (AB)
8. Backer rod and sealant, see [page 104](#) (AB)
9. Intermittent vertical furring or shims
10. Sill flashing over window trim

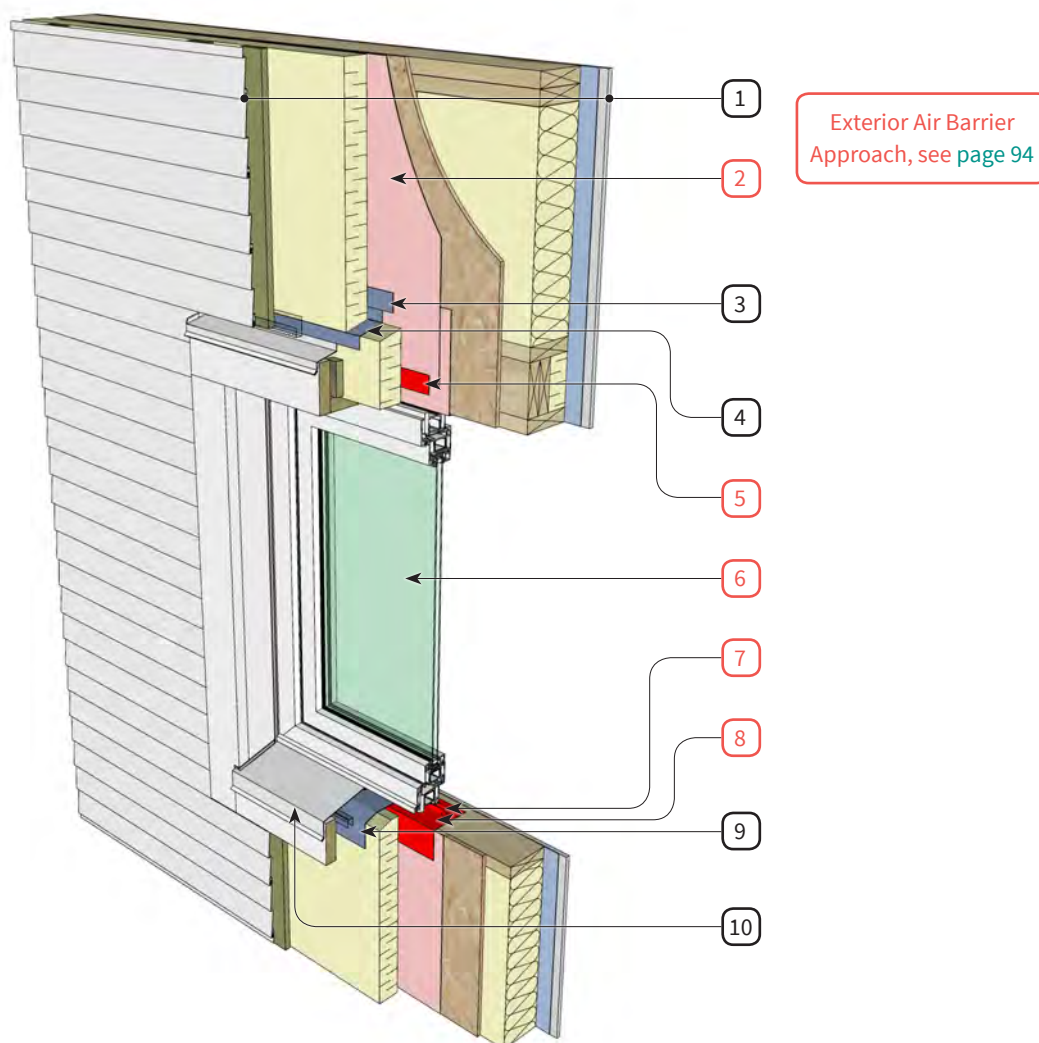
Detail 02**Non-Flange Window in Split-Insulated Wall with Thin Exterior Insulation**

1. Split-insulated wall assembly, see [page 58](#)
2. Vapour-permeable sheathing membrane (AB)
3. Sheathing tape over top edge of flashing membrane
4. Thermally broken through-wall flashing; self-adhered flashing membrane on sloped insulation over top edge of head flashing
5. Sheathing tape at all laps in sheathing membrane
6. Window assembly sealed to air barrier with backer rod and sealant, see [page 104](#) (AB)
7. Backer rod and sealant, see [page 104](#) (AB)
8. Self-adhered impermeable membrane (AB)
9. Self-adhered skirt flashing membrane
10. Sill flashing over window trim

Detail 03

Non-Flange Window in Split-Insulated Wall with Thick Exterior Insulation

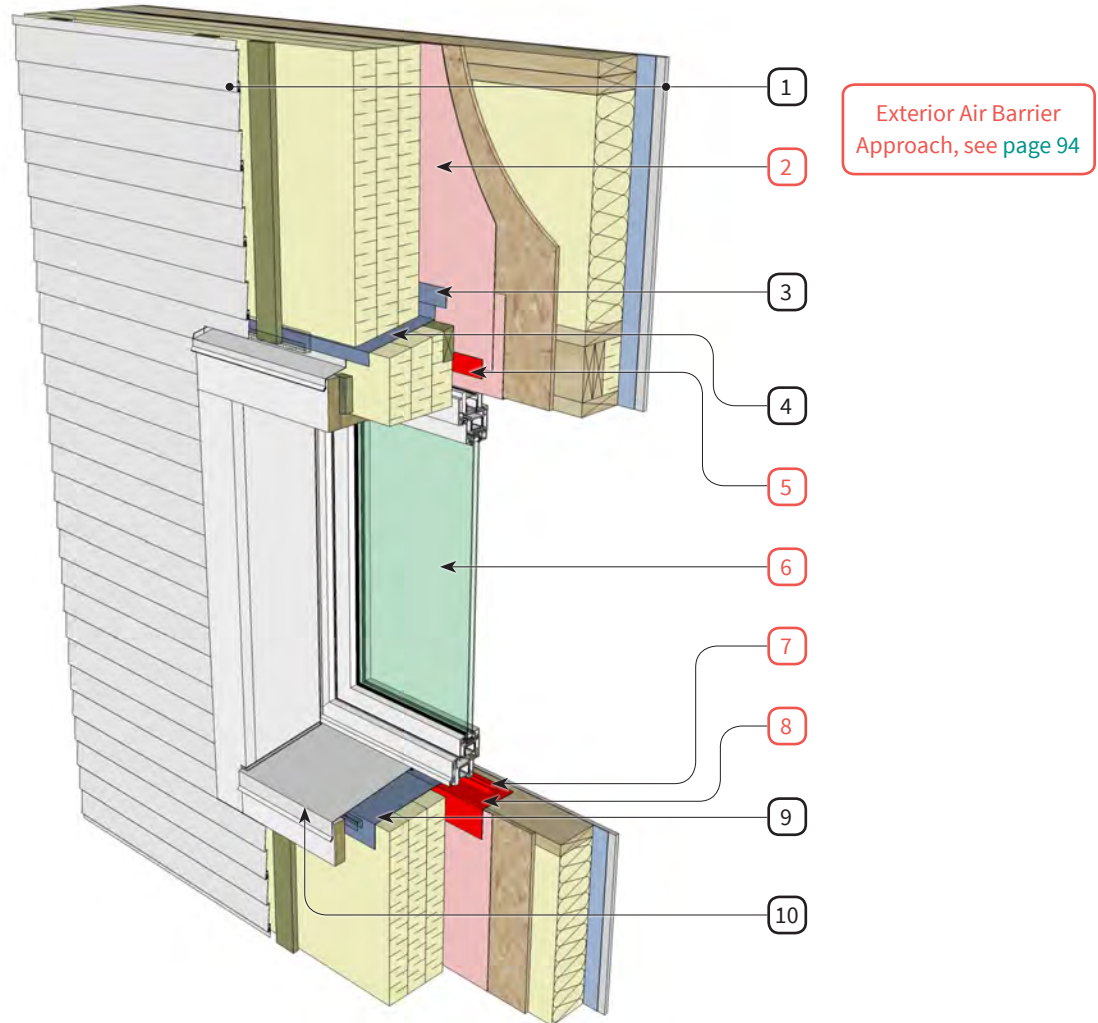

1. Split-insulated wall assembly, see [page 60](#)
2. Vapour-permeable sheathing membrane (AB)
3. Sheathing tape over top edge of flashing membrane
4. Thermally broken through-wall flashing; Self-adhered flashing membrane on sloped insulation over top edge of head flashing
5. Sheathing tape at all laps in sheathing membrane (AB)
6. Window assembly sealed to air barrier with backer rod and sealant, see [page 104](#) (AB)
7. Backer rod and sealant, see [page 104](#) (AB)
8. Self-adhered impermeable sill membrane (AB)
9. Self-adhered skirt flashing membrane
10. Sill flashing over window trim

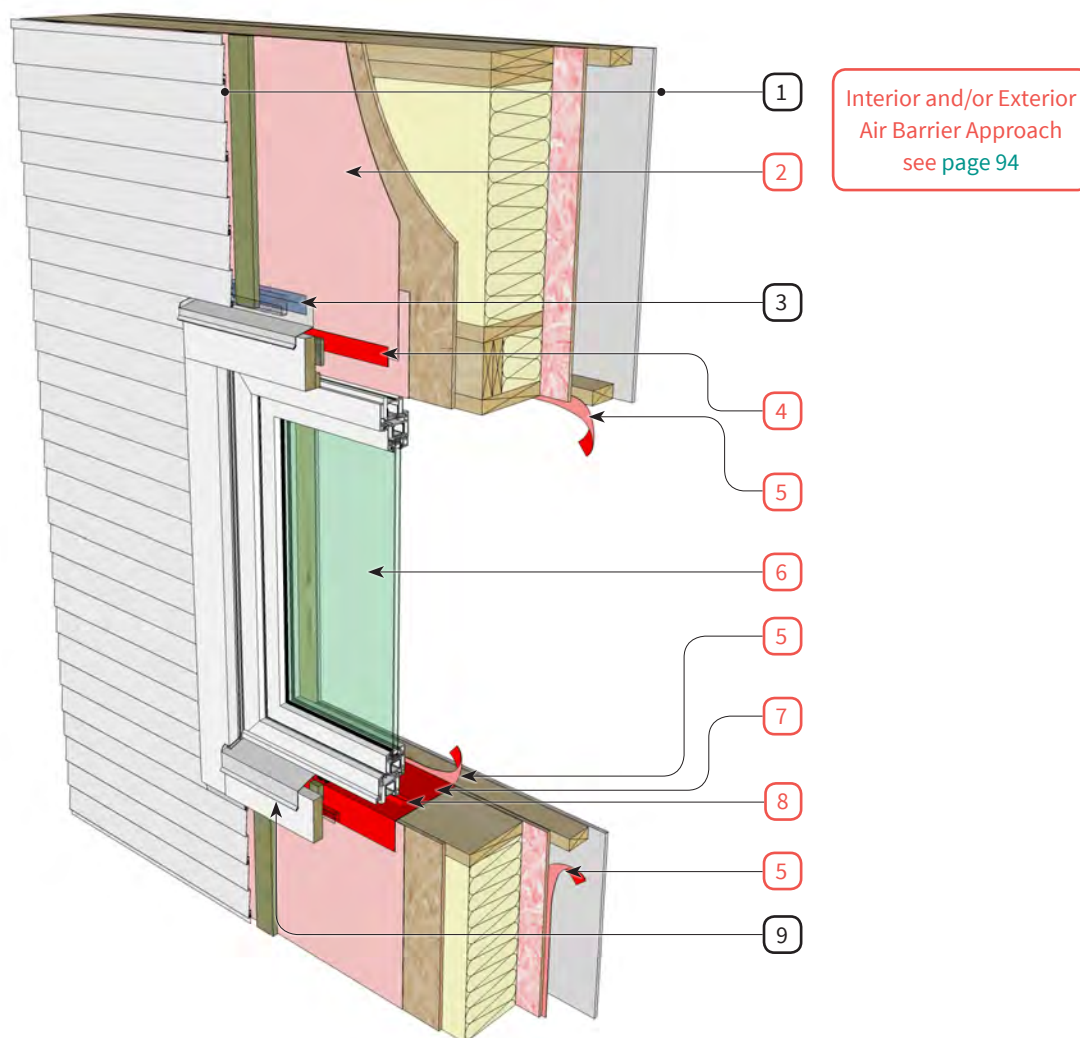
Detail 04**Non-Flange Window in Deep Stud-Insulated Wall with Service Cavity**

1. Deep stud-insulated wall assembly with service cavity, see [page 62](#)
2. Vapour-permeable sheathing membrane (AB)
3. Head flashing with sheathing tape over top edge
4. Sheathing tape at all laps in sheathing membrane (AB)
5. Tape at all seams at interior sheathing (AB)
6. Window assembly sealed to air barrier with backer rod and sealant, see [page 104](#) (AB)
7. Self-adhered impermeable sill membrane (AB)
8. Backer rod and sealant, see [page 104](#) (AB)
9. Sill flashing over window trim

Detail 05

Transition Between Stud-Insulated Wall and Insulated Attic Sloped Roof

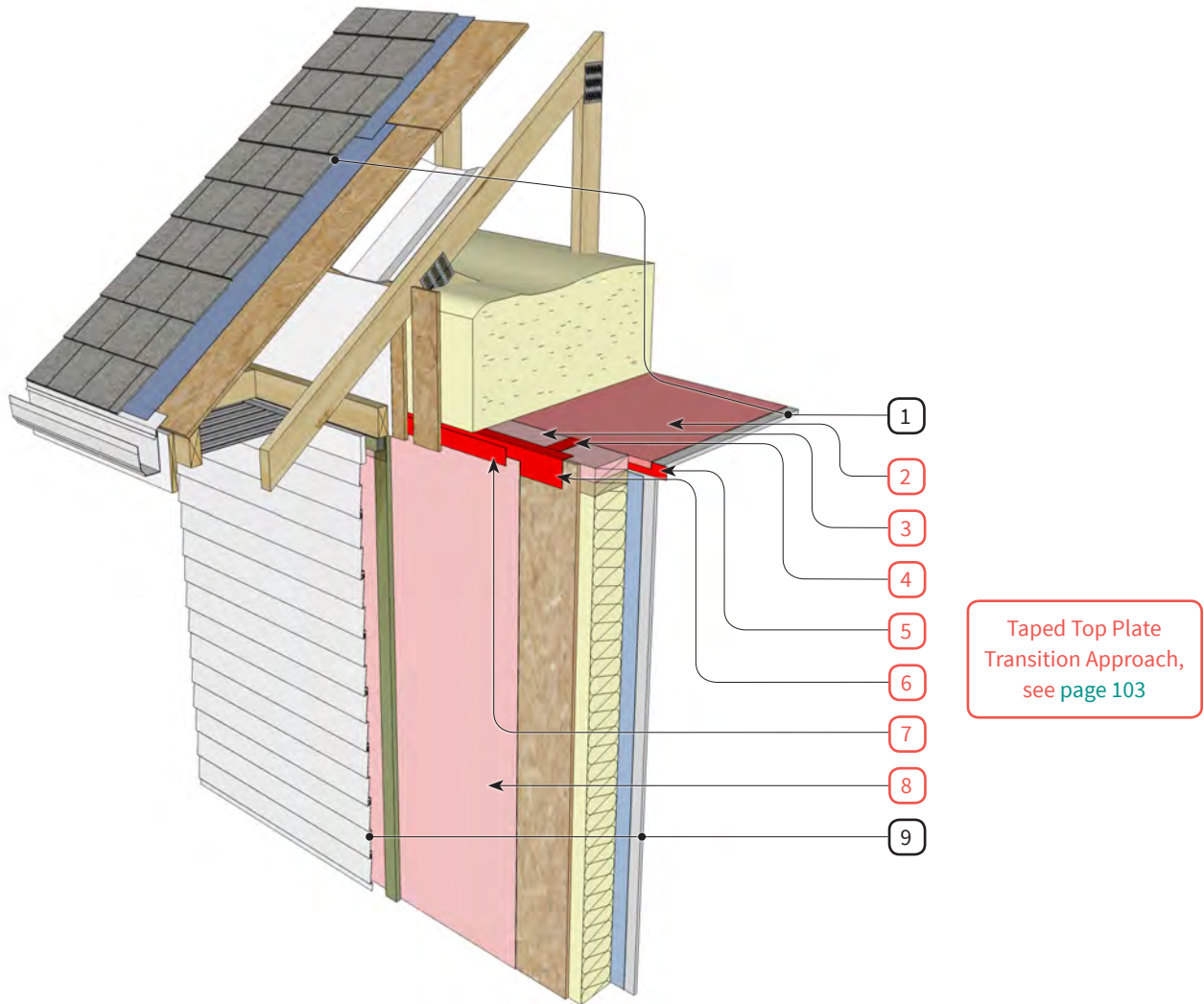

1. Insulated attic sloped roof assembly, see [page 66](#)
2. Sealed polyethylene roof air barrier system, AB see [page 97](#)
3. Wall top plate AB
4. Tape at all joints in wall top plate AB
5. Tape between ceiling polyethylene membrane termination and wall top plate tape AB
6. Tape over exterior sheathing and wall top plate AB
7. Tape over sheathing membrane to wall top plate tape AB
8. Vapour-permeable sheathing membrane AB
9. Stud-insulated wall assembly, see [page 56](#)

Detail 06

Transition Between Split-Insulated Wall with Thin Exterior Insulation and Insulated Attic Sloped Roof

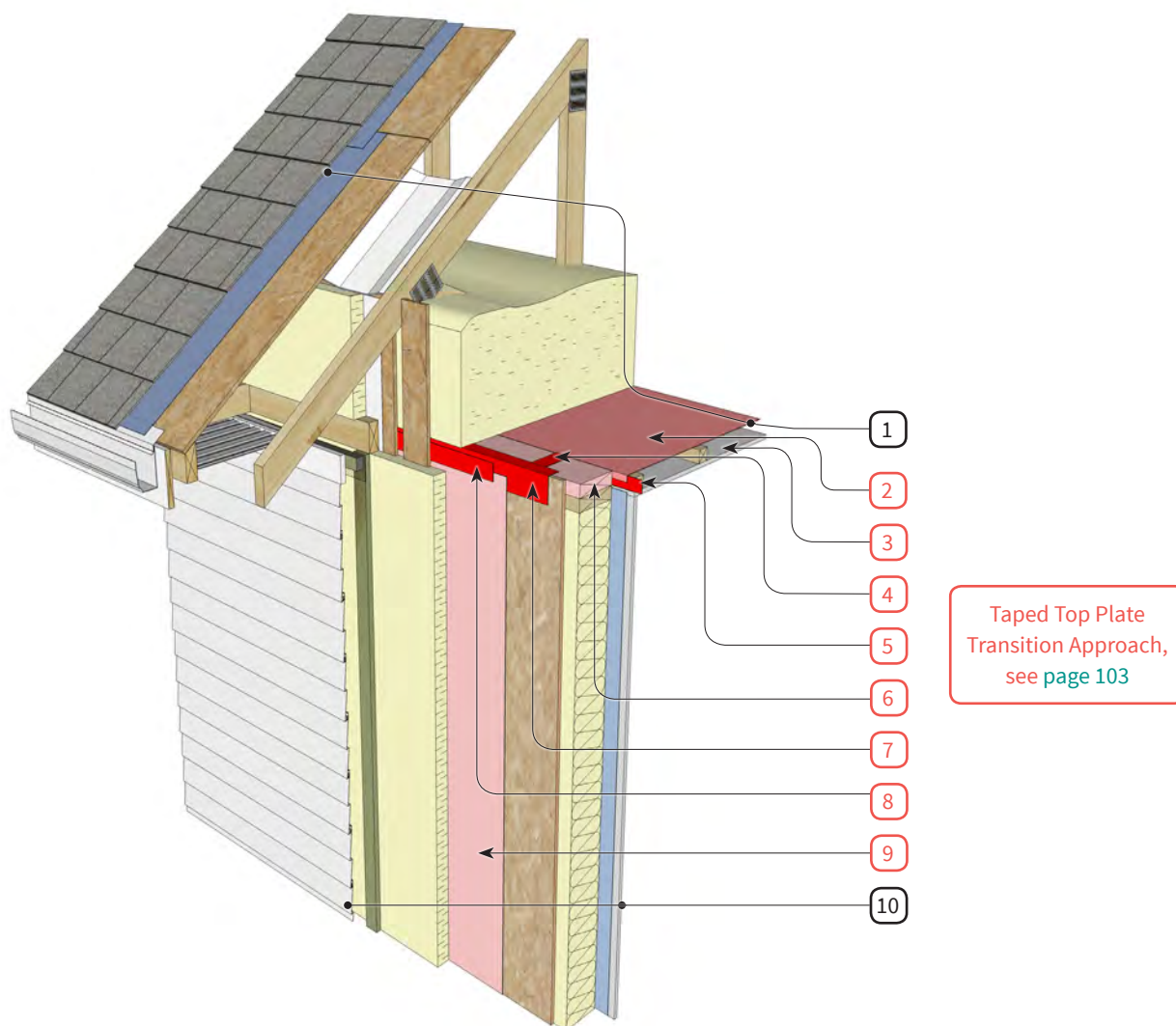

1. Insulated attic sloped roof assembly, see [page 66](#)
2. Sealed polyethylene roof air barrier system, see [page 97](#) AB
3. Service cavity
4. Tape at all joints in wall top plate AB
5. Tape between ceiling polyethylene membrane termination and wall top plate tape AB
6. Wall top plate AB
7. Tape over exterior sheathing and wall top plate AB
8. Tape over sheathing membrane to wall top plate tape AB
9. Vapour-permeable sheathing membrane AB
10. Split-insulated wall assembly, see [page 58](#)

Detail 07

Transition Between Split-Insulated Wall with Thick Exterior Insulation and Insulated Attic Sloped Roof

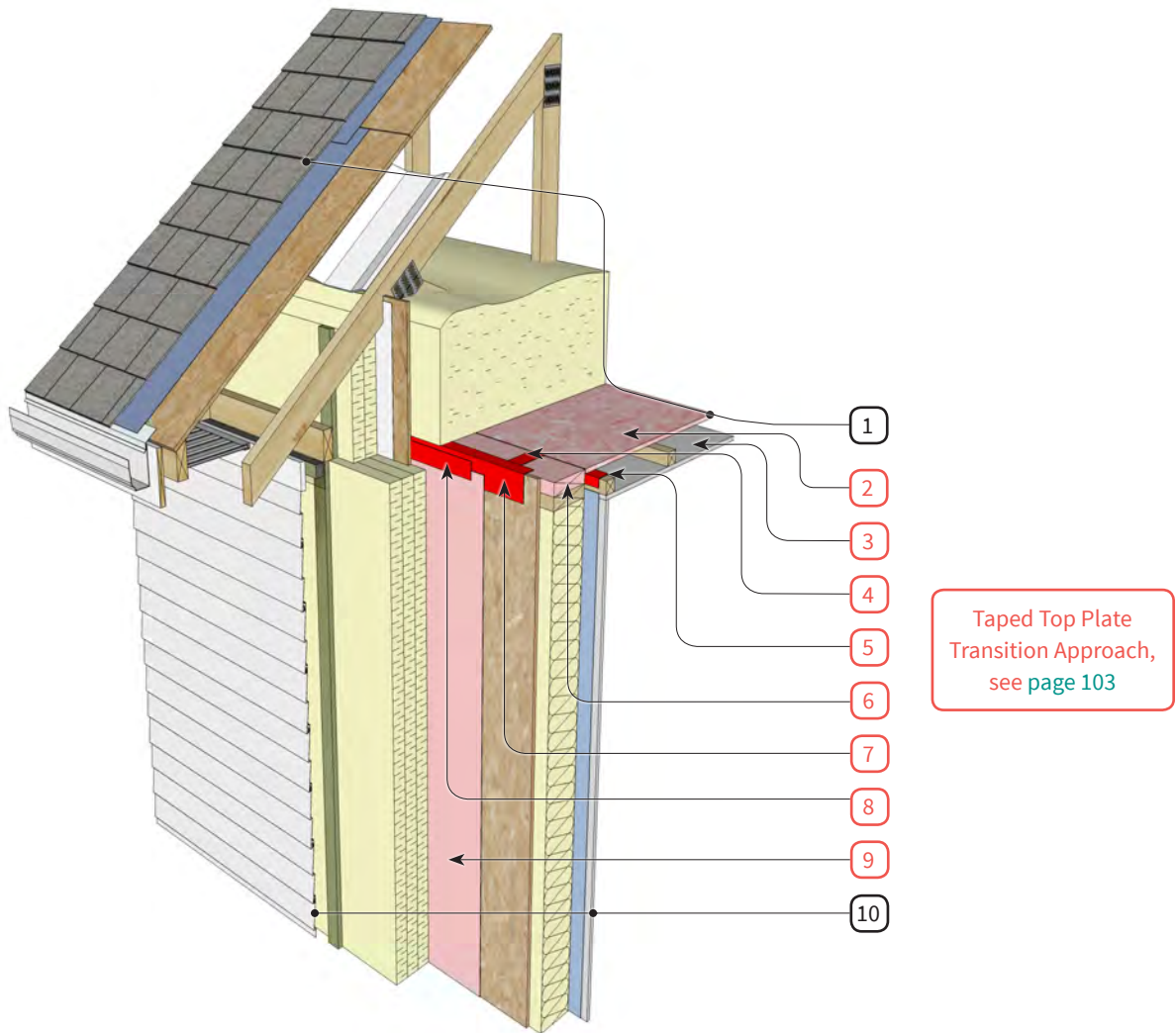

- | | |
|---|---|
| <ol style="list-style-type: none"> 1. Insulated attic sloped roof assembly, see page 66 2. Sealed interior sheathing roof air barrier system, AB see page 97 3. Service cavity 4. Tape at all joints in wall top plate AB 5. Tape between interior attic sheathing termination AB and wall top plate | <ol style="list-style-type: none"> 6. Wall top plate AB 7. Tape over exterior sheathing and wall top plate AB 8. Tape over sheathing membrane to wall AB top plate tape 9. Vapour-permeable sheathing membrane AB 10. Split-insulated wall assembly, see page 60 |
|---|---|

Taped Top Plate
Transition Approach,
see [page 103](#)

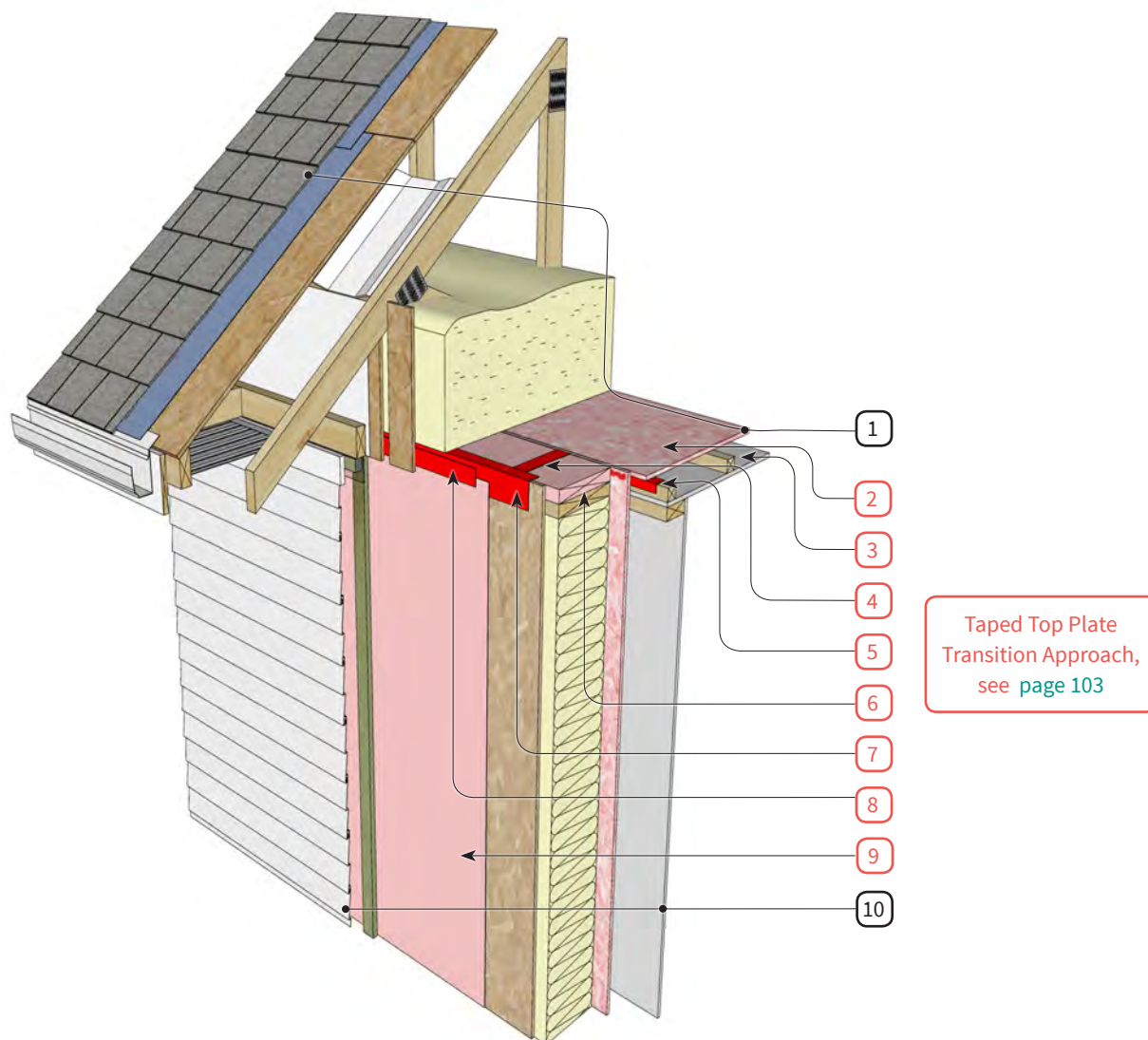
Detail 08**Transition Between Deep Stud-Insulated Wall and Insulated Attic Sloped Roof**

Taped Top Plate
Transition Approach,
see [page 103](#)

1. Insulated attic sloped roof assembly, see [page 66](#)
2. Sealed interior sheathing roof air barrier system, see [page 97](#) (AB)
3. Service cavity
4. Tape at all joints in wall top plate (AB)
5. Interior wall sheathing set into sealant at wall top plate, tape between attic sheathing and wall sheathing (AB)
6. Wall top plate (AB)
7. Tape over exterior sheathing and wall top plate (AB)
8. Tape over sheathing membrane to wall top plate tape (AB)
9. Vapour-permeable sheathing membrane (AB)
10. Deep stud-insulated wall assembly with service cavity, see [page 62](#)

Detail 09

Transition Between Stud-Insulated Wall and Joist-Insulated Sloped Roof

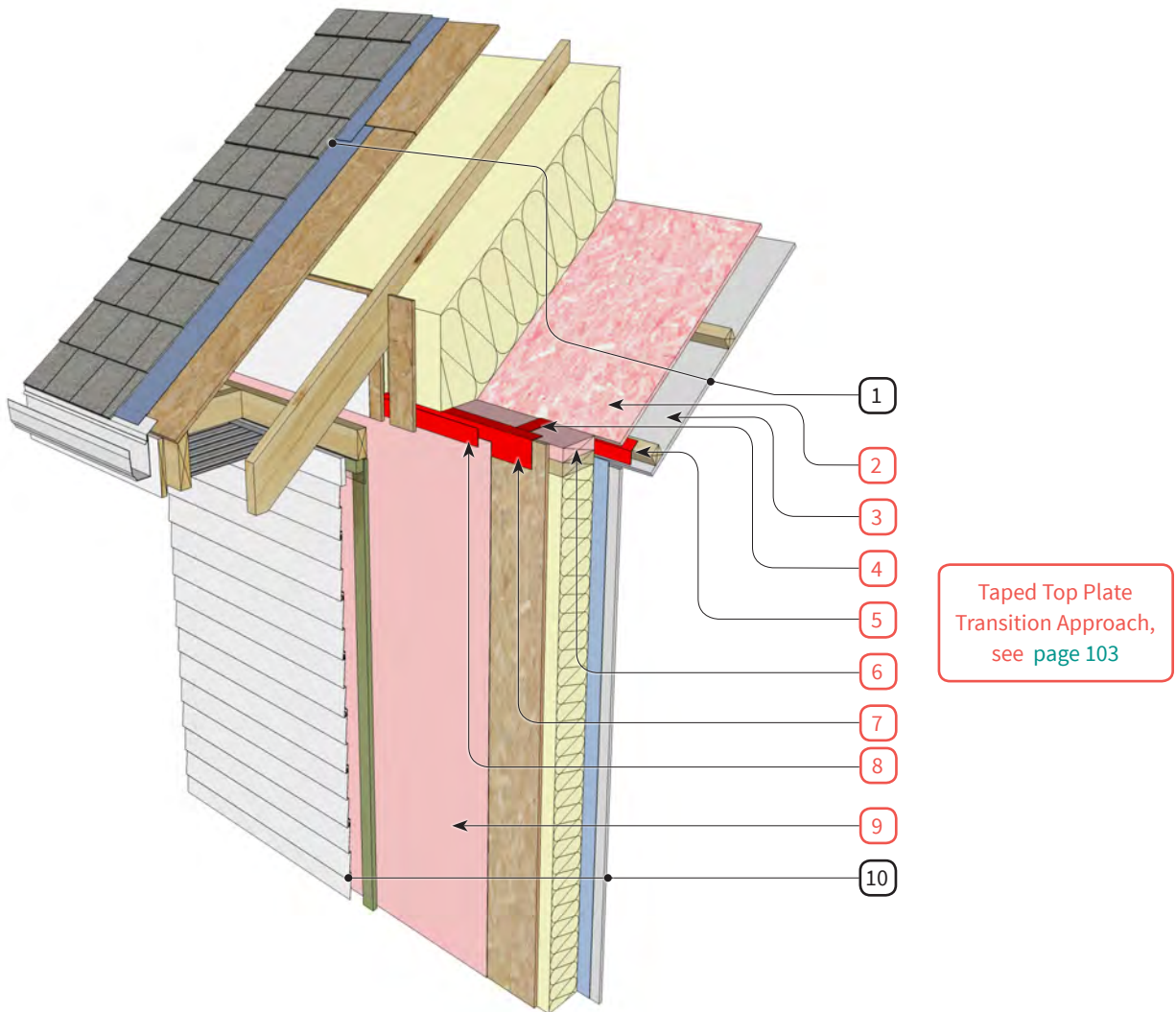

1. Joist-insulated sloped roof assembly, see [page 68](#)
2. Sealed interior sheathing roof air barrier system, AB see [page 97](#)
3. Service cavity
4. Tape at all joints in wall top plate AB
5. Tape between interior attic sheathing termination AB and wall top plate
6. Wall top plate AB
7. Tape over exterior sheathing and wall top plate AB
8. Tape over sheathing membrane to wall AB top plate tape
9. Vapour-permeable sheathing membrane AB
10. Stud-insulated wall assembly, see [page 56](#)

Taped Top Plate
Transition Approach,
see [page 103](#)

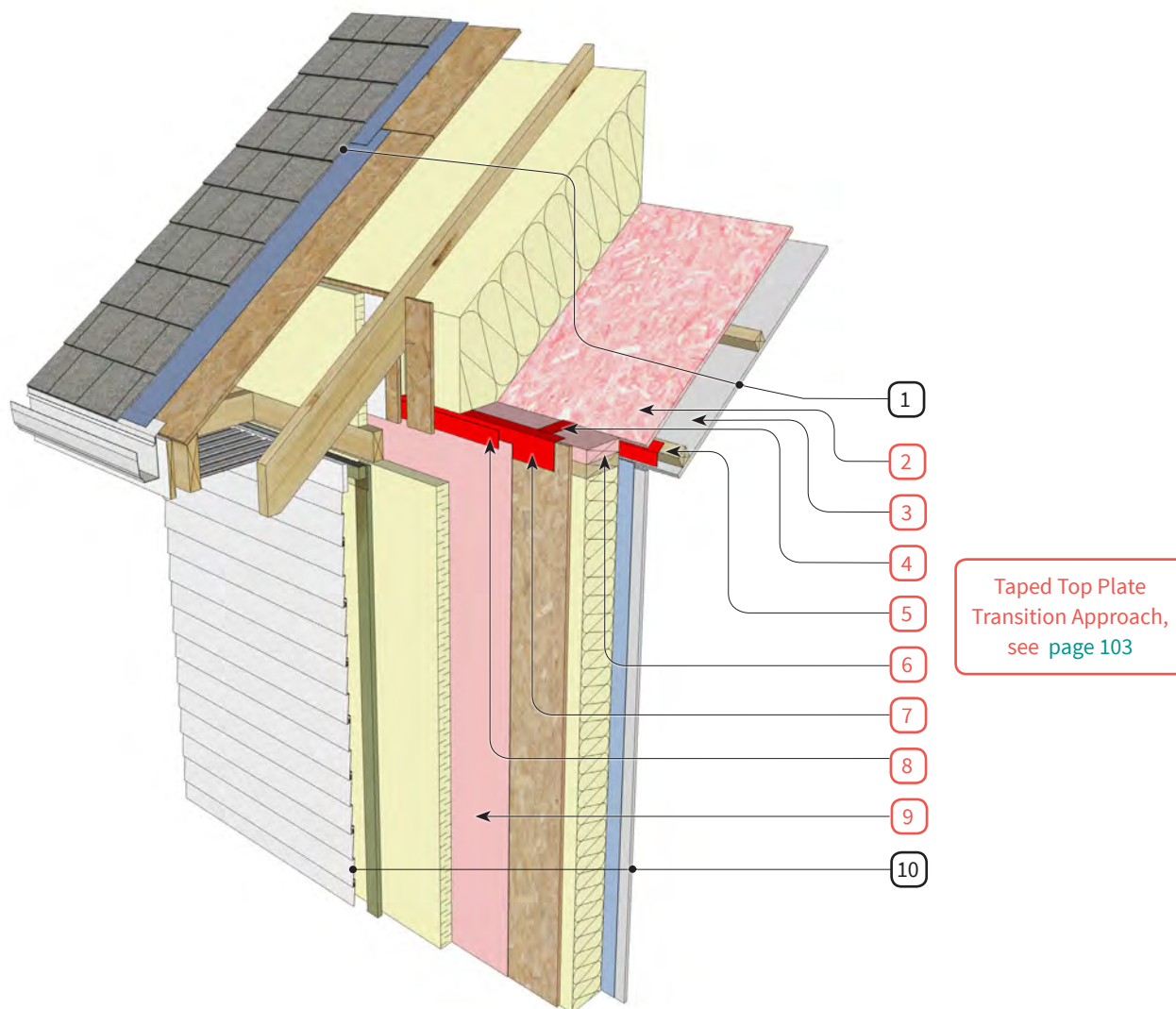
Detail 10**Transition Between Split-Insulated Wall with Thin Exterior Insulation and Joist-Insulated Sloped Roof**

1. Joist-insulated sloped roof assembly, see [page 68](#)
2. Sealed interior sheathing roof air barrier system, [\(AB\)](#) see [page 97](#)
3. Service cavity
4. Tape at all joints in wall top plate [\(AB\)](#)
5. Tape between interior attic sheathing termination [\(AB\)](#) and wall top plate
6. Wall top plate [\(AB\)](#)
7. Tape over exterior sheathing and wall top plate [\(AB\)](#)
8. Tape over sheathing membrane to wall top plate tape [\(AB\)](#)
9. Vapour-permeable sheathing membrane [\(AB\)](#)
10. Split-insulated wall assembly, see [page 58](#)

Detail 11

Transition Between Deep Stud-Insulated Wall and Joist-Insulated Sloped Roof

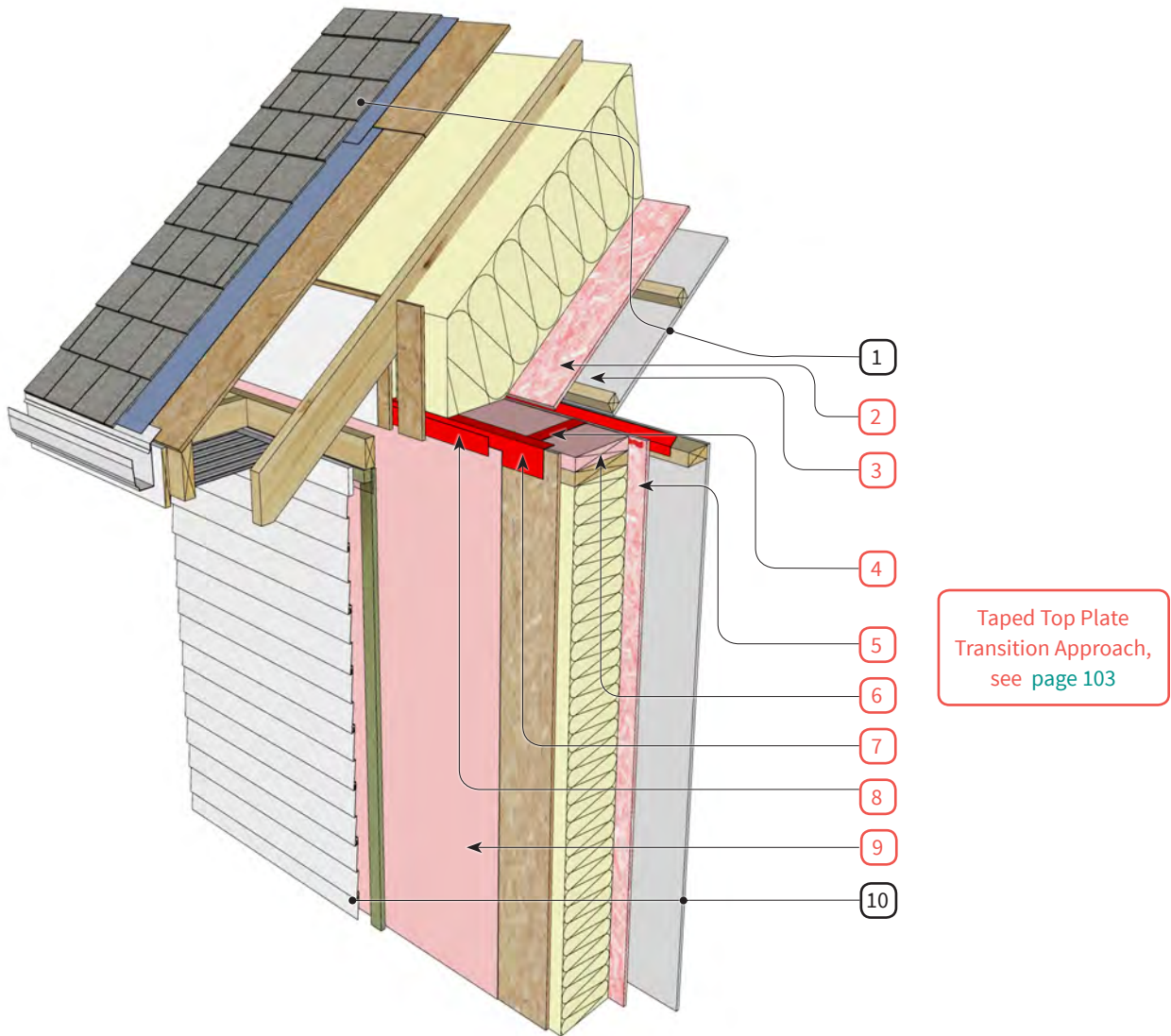

1. Joist-insulated sloped roof assembly, see [page 68](#)
2. Sealed interior sheathing roof air barrier system AB taped to interior sheathing, see [page 97](#)
3. Service cavity
4. Tape at all joints in wall top plate AB
5. Interior wall sheathing set into sealant at wall top plate
6. Wall top plate AB
7. Tape over exterior sheathing and wall top plate AB
8. Tape over sheathing membrane to wall AB top plate tape
9. Vapour-permeable sheathing membrane AB
10. Deep stud-insulated wall assembly with service cavity, see [page 62](#)

Detail 12

Transition Between Split-Insulated Wall with Thick Exterior Insulation and Exterior-Insulated Roof

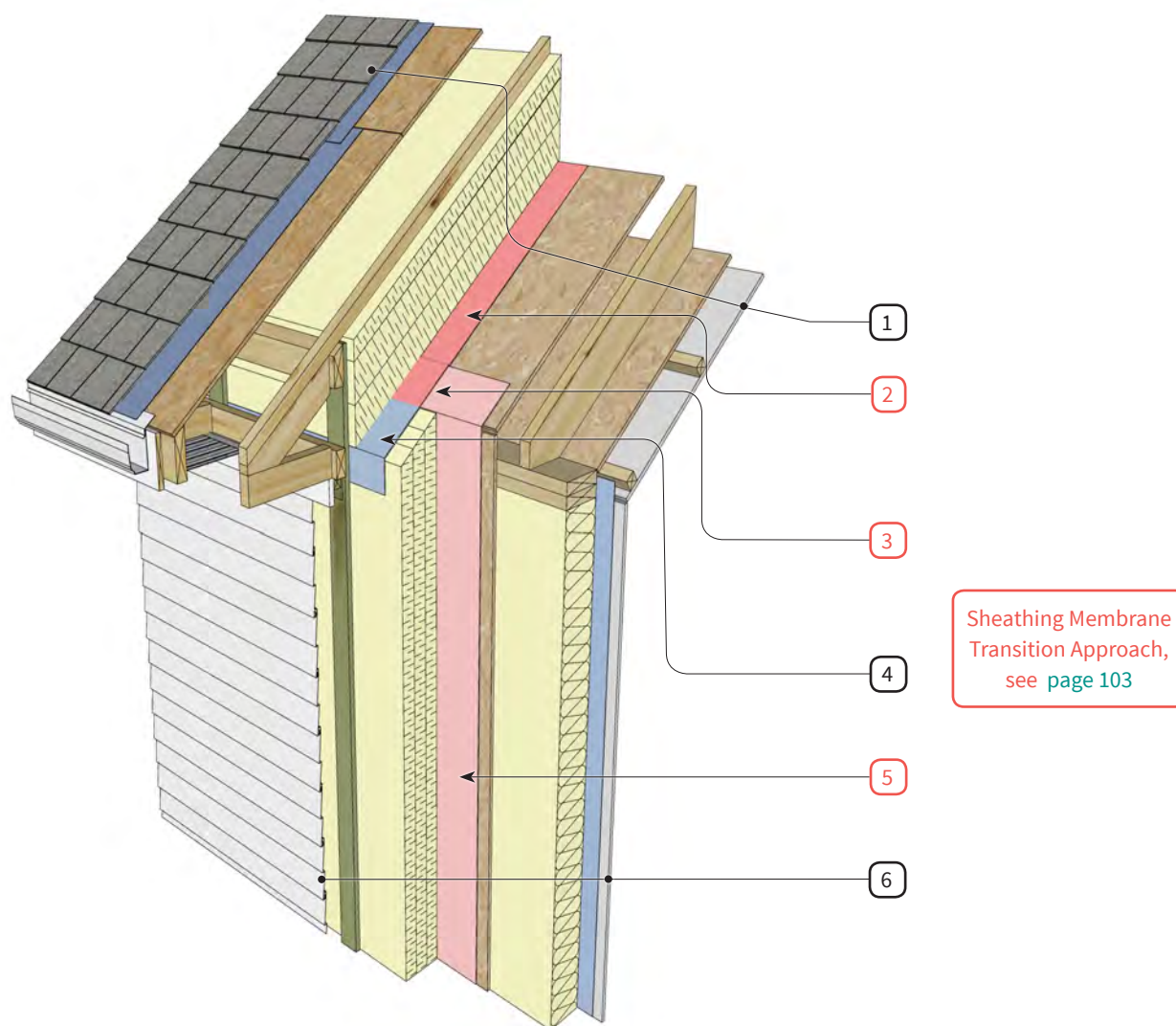

1. Exterior-insulated sloped roof assembly, see [page 70](#)
2. Roof sheathing membrane AB
3. Lap roof sheathing membrane over wall sheathing membrane AB
4. Lap roof sheathing membrane over sloped top edge of exterior insulation
5. Vapour permeable sheathing membrane AB
6. Split-insulated wall assembly, see [page 60](#)

Detail 13

Transition Between Stud-Insulated Wall and Joist-Insulated Vented Flat Roof with Parapet

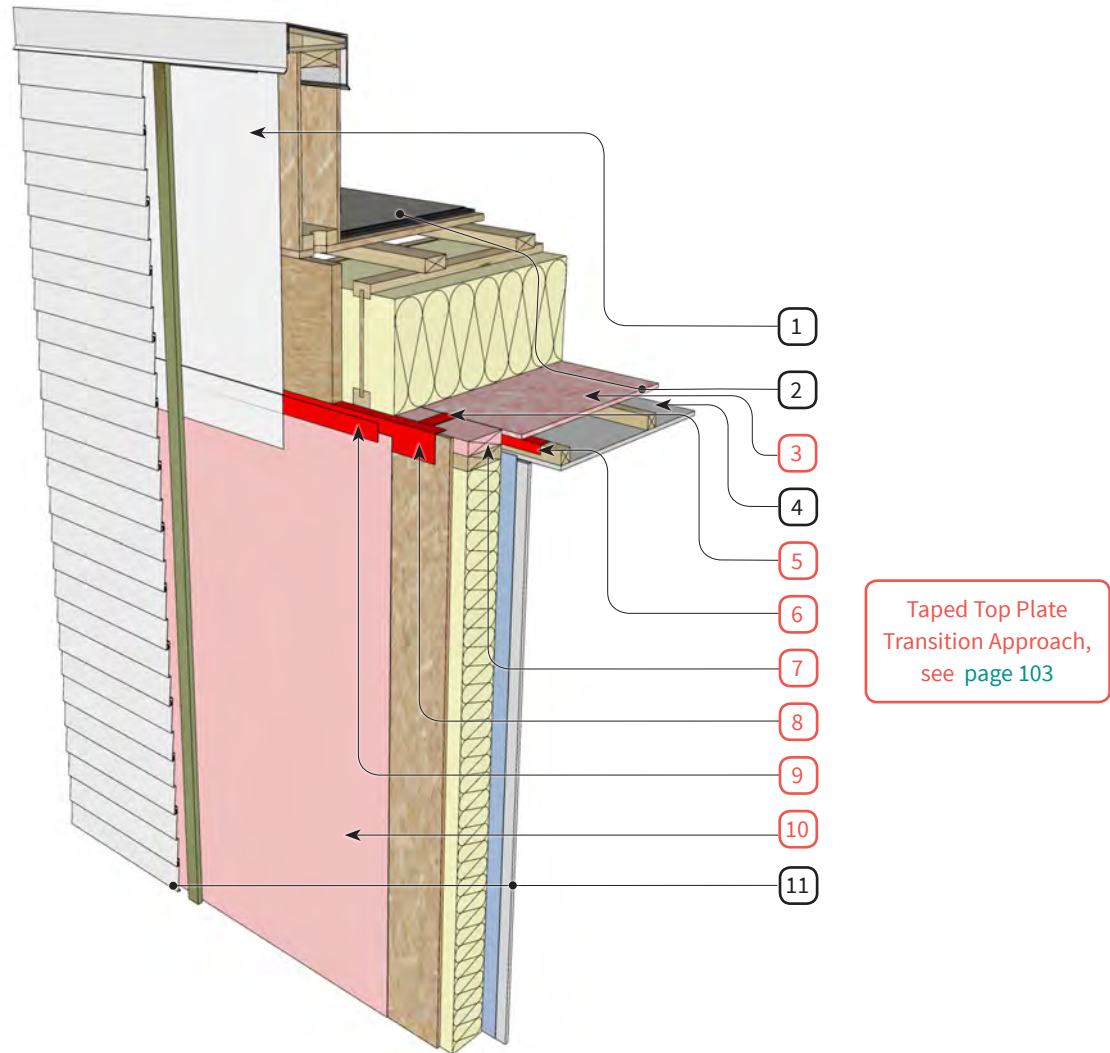

1. Parapet sheathing membrane, positively lapped
2. Joist-insulated vented flat roof assembly, see [page 73](#)
3. Sealed interior sheathing roof air barrier system, AB see [page 97](#)
4. Service cavity
5. Tape at all joints in wall top plate AB
6. Tape between interior ceiling sheathing termination AB and wall top plate
7. Wall top plate AB
8. Tape over exterior sheathing and wall top plate AB
9. Tape over sheathing membrane to wall AB top plate tape
10. Vapour-permeable sheathing membrane AB
11. Stud-insulated wall assembly, see [page 56](#)

Detail 14

Transition Between Stud-Insulated Wall and Exterior-Insulated Conventional Flat Roof with Parapet

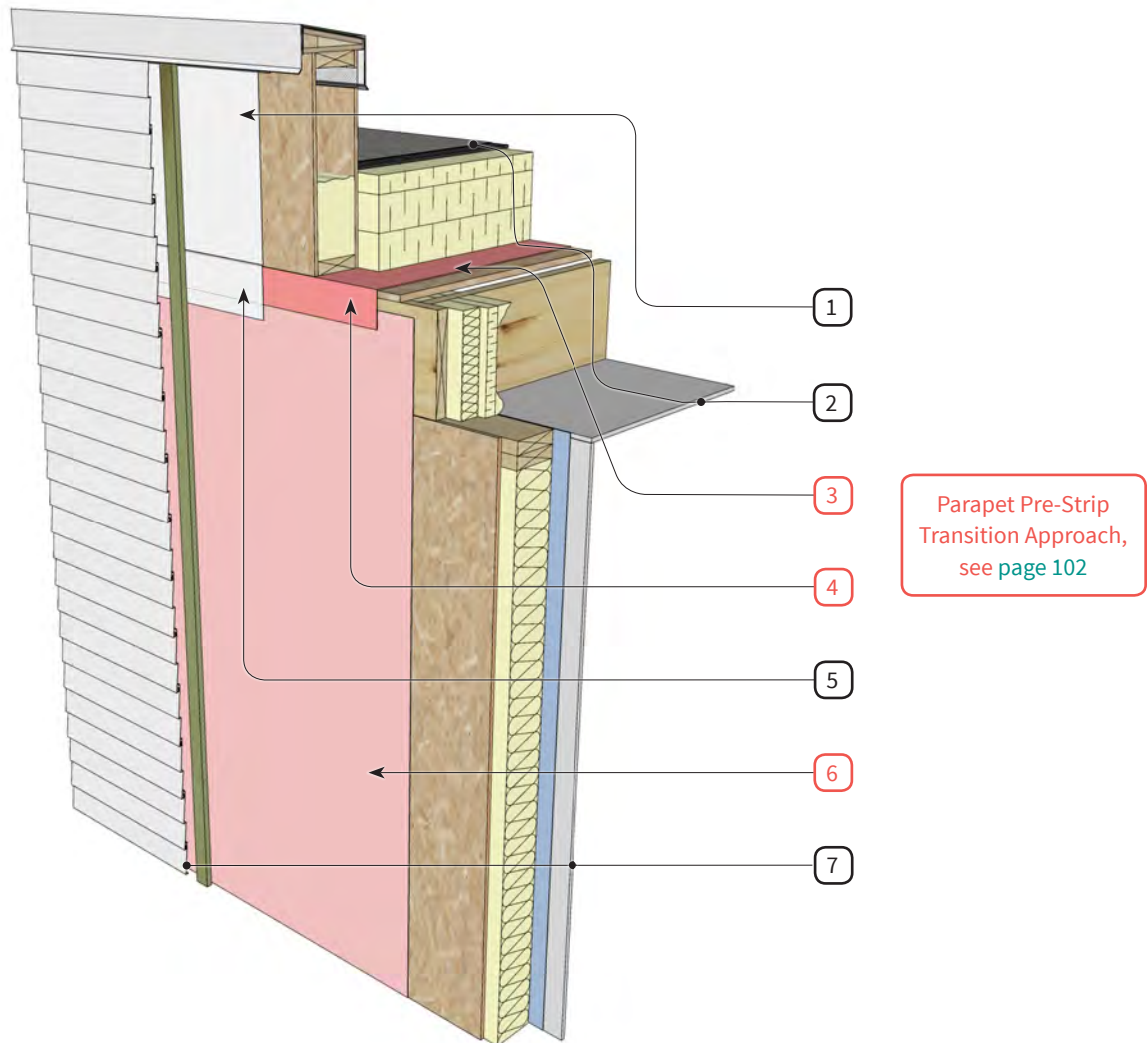

1. Parapet sheathing membrane
2. Exterior-insulated conventional flat roof, see [page 75](#)
3. Roof sheathing membrane **(AB)**
4. Lap roof sheathing membrane over wall sheathing membrane **(AB)**
5. Lap parapet sheathing membrane over wall sheathing membrane
6. Vapour-permeable sheathing membrane **(AB)**
7. Stud-insulated wall assembly, see [page 56](#)

Detail 15

Transition Between Split-Insulated Wall and Exterior-Insulated Conventional Flat Roof with Parapet

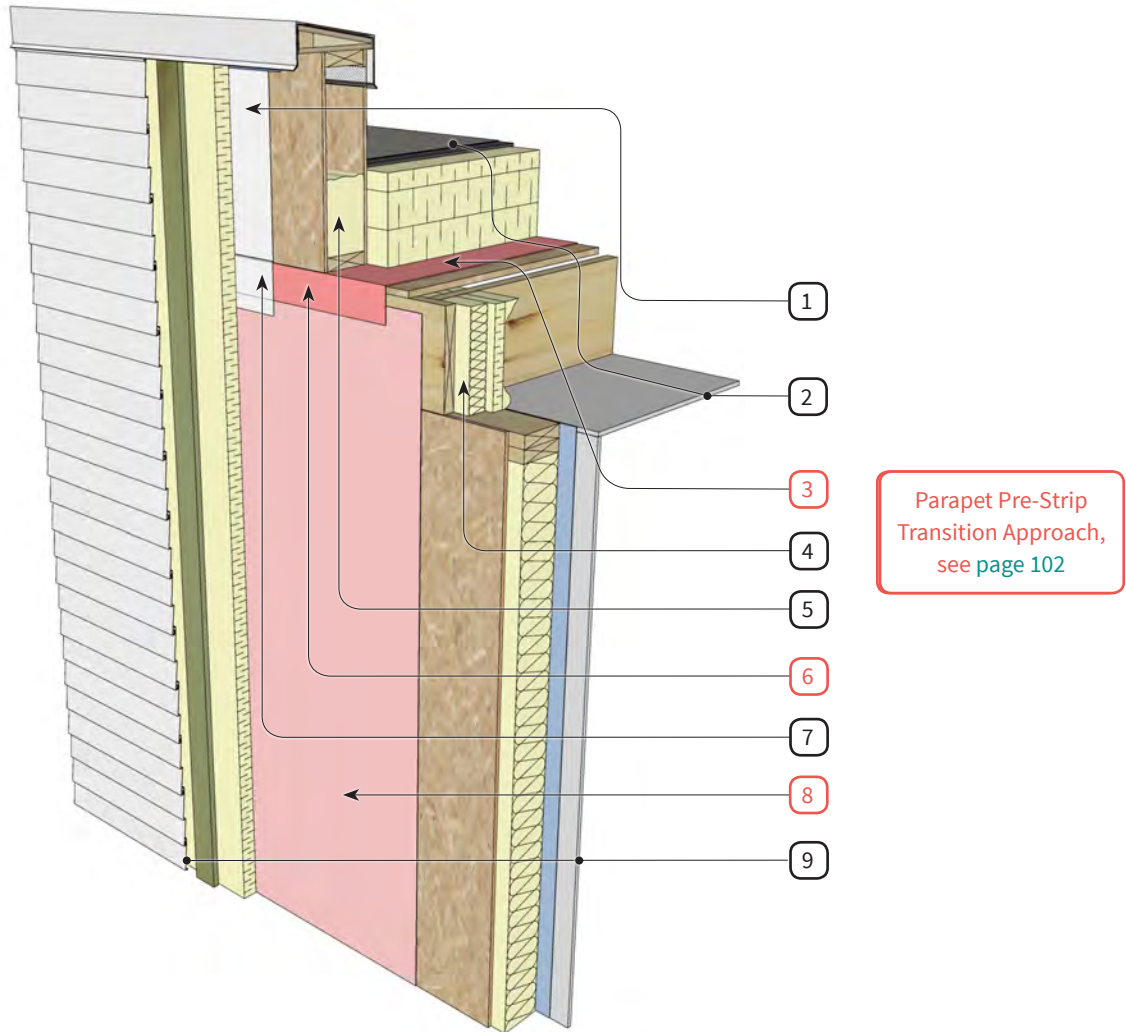

- | | |
|---|--|
| <ol style="list-style-type: none"> 1. Parapet sheathing membrane 2. Exterior-insulated conventional flat roof, see page 75 3. Roof sheathing membrane AB 4. Insulation in joist cavities 5. Insulation in parapet wall stud cavities | <ol style="list-style-type: none"> 6. Lap roof sheathing membrane over wall sheathing membrane AB 7. Lap parapet sheathing membrane over wall sheathing membrane 8. Vapour-permeable sheathing membrane AB 9. Split-insulated wall assembly, see page 58 |
|---|--|

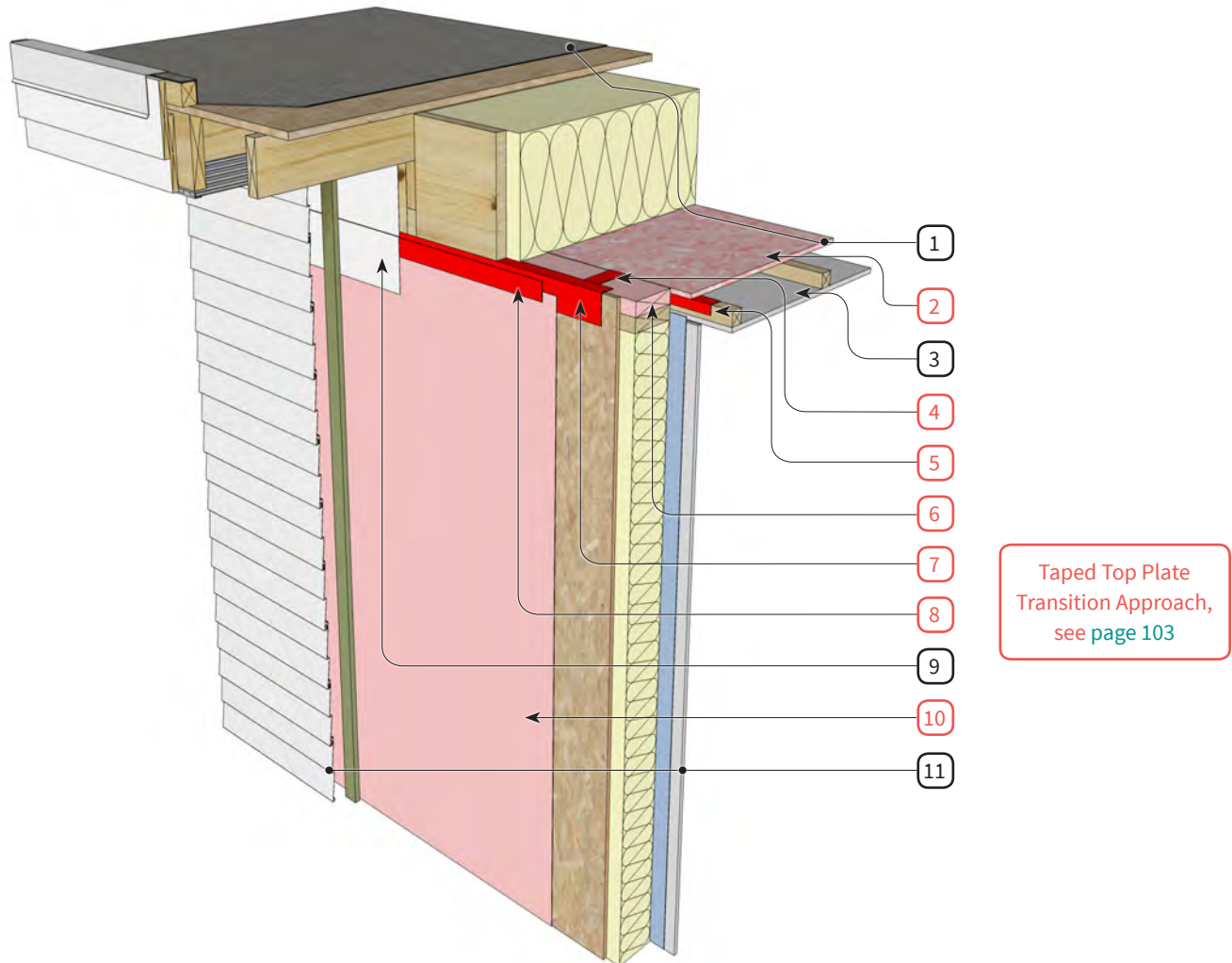
Detail 16**Transition Between Stud-Insulated Wall and Joist-Insulated Vented Flat Roof with Overhang**

1. Joist-insulated vented flat roof assembly, see [page 73](#)
2. Sealed interior sheathing roof air barrier system, [\(AB\)](#) see [page 97](#)
3. Service cavity
4. Tape at all joints in wall top plate [\(AB\)](#)
5. Tape between interior ceiling sheathing termination [\(AB\)](#) and wall top plate
6. Wall top plate [\(AB\)](#)
7. Tape over exterior sheathing and wall top plate [\(AB\)](#)
8. Tape over sheathing membrane to wall top plate tape [\(AB\)](#)
9. Sheathing membrane, positively lapped
10. Vapour-permeable sheathing membrane [\(AB\)](#)
11. Stud-insulated wall assembly, see [page 56](#)

Detail 17 Stud-Insulated Wall at Rim Joist

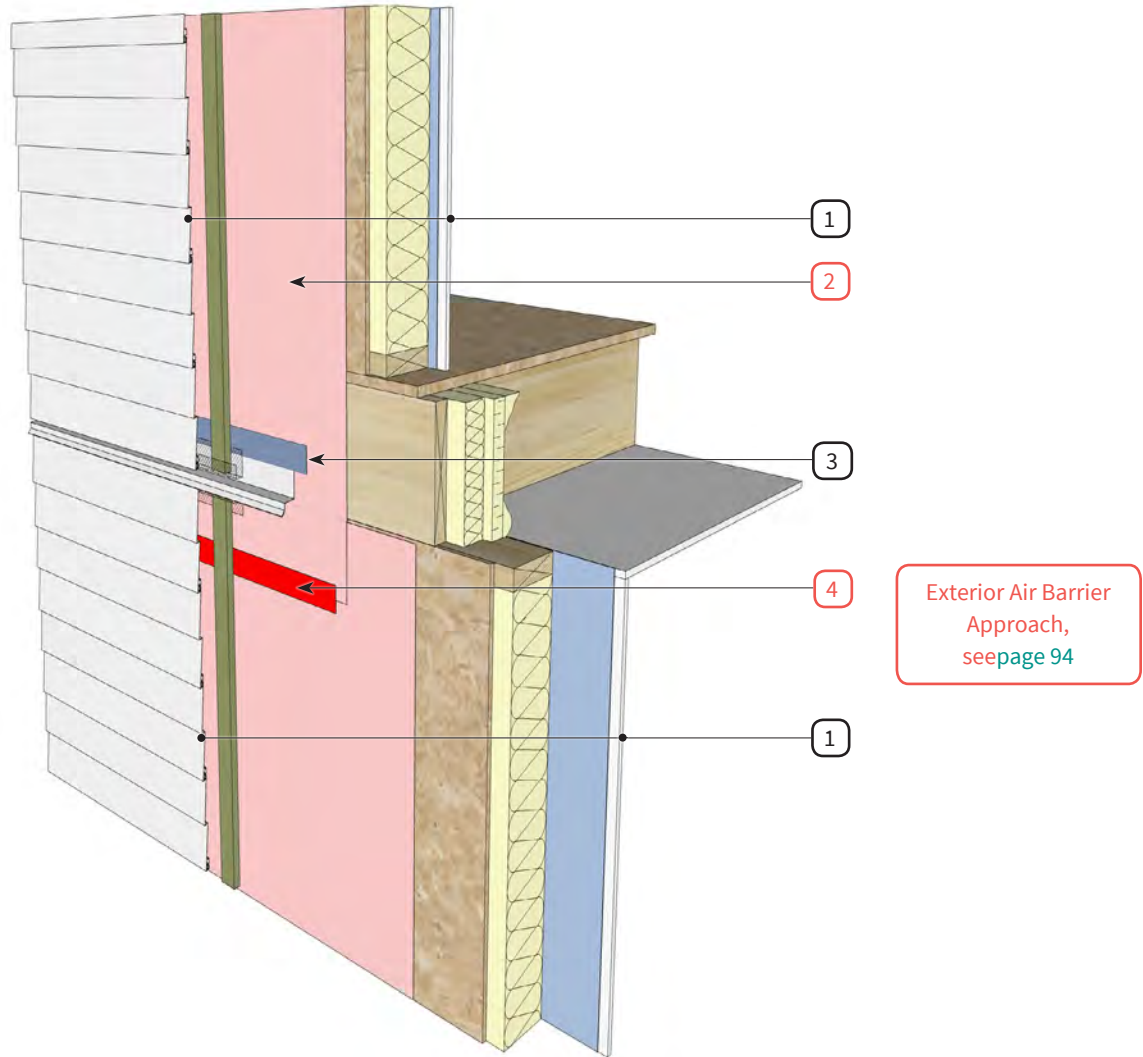

1. Stud-insulated wall assembly, see [page 56](#)
2. Vapour-permeable sheathing membrane **AB**
3. Sheathing tape over top edge of cross-cavity flashing
4. Sheathing tape at all laps in sheathing membrane **AB**

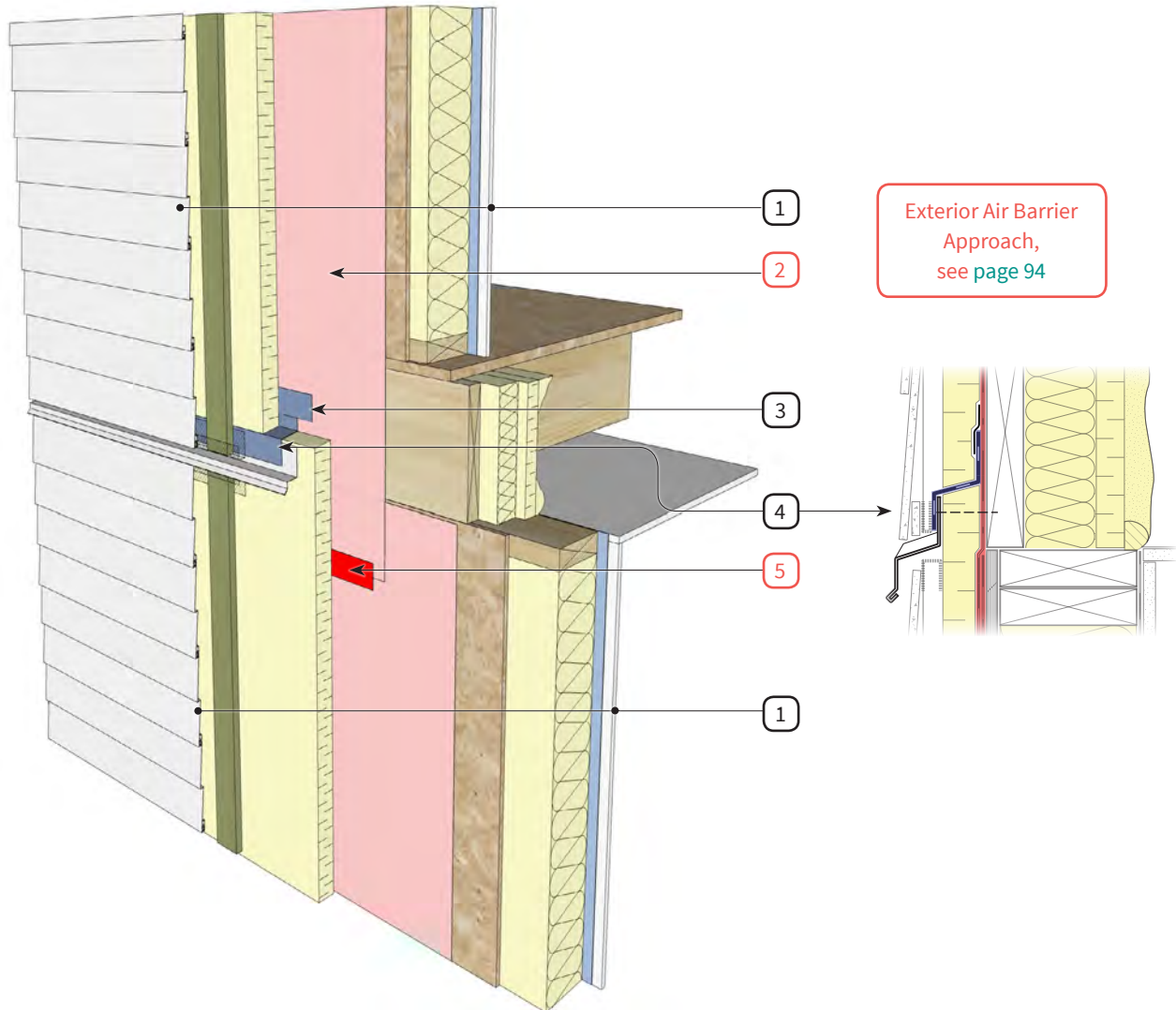
Detail 18**Split-Insulated Wall with Thin Exterior Insulation at Rim Joist**

1. Split-insulated wall assembly, see [page 58](#)
2. Vapour-permeable sheathing membrane **(AB)**
3. Sheathing tape over top edge of cross-cavity flashing membrane
4. Thermally broken through-wall flashing;
Self-adhered flashing membrane on sloped
insulation over top edge of cross-cavity flashing
5. Sheathing tape at all laps in sheathing membrane **(AB)**

Detail 19 Split-Insulated Wall with Thick Exterior Insulation at Rim Joist

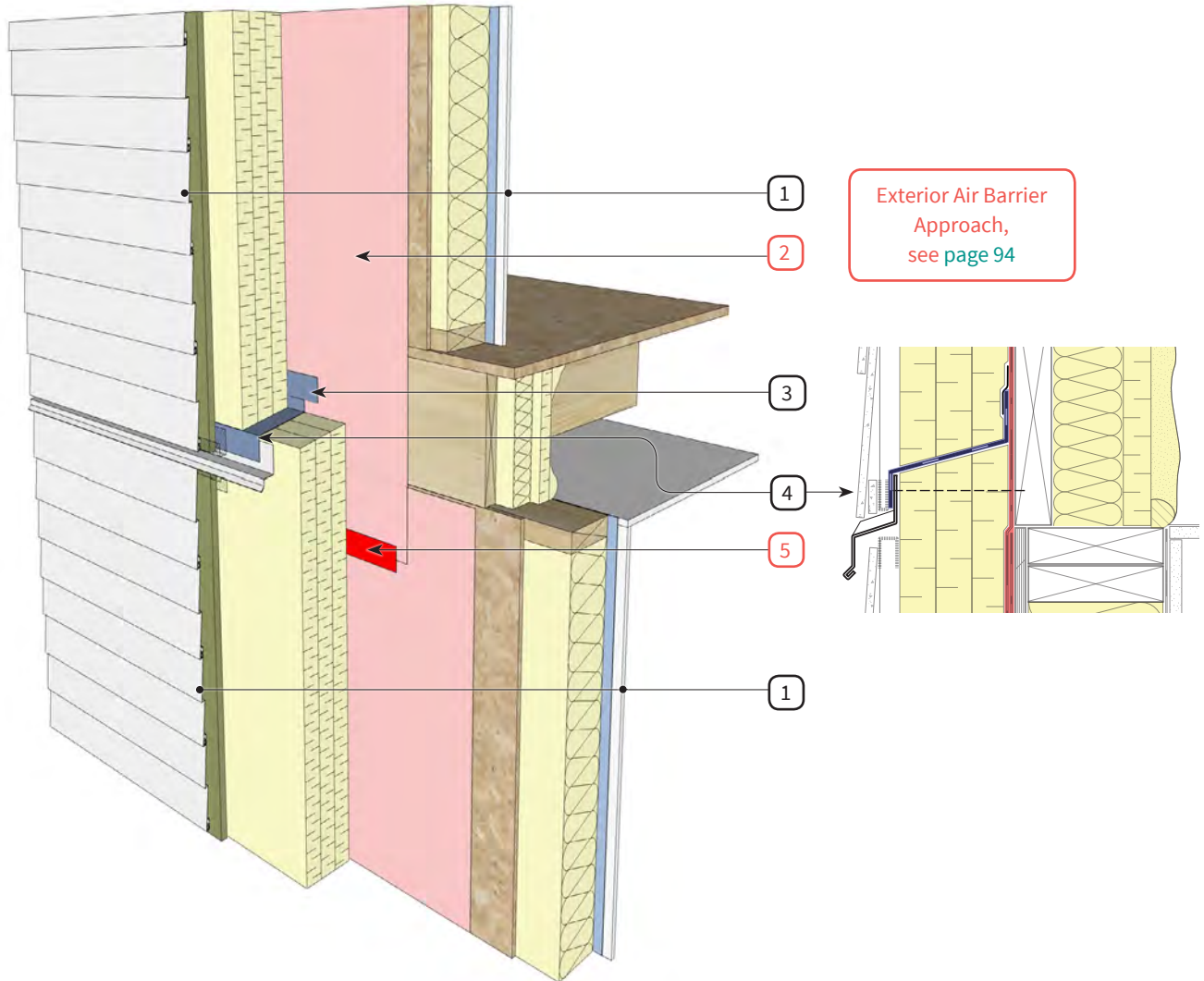

1. Split-insulated wall assembly, see [page 60](#)
2. Vapour-permeable sheathing membrane **(AB)**
3. Sheathing tape over top edge of cross-cavity flashing membrane
4. Thermally broken through-wall flashing;
Self-adhered flashing membrane on sloped insulation over top edge of cross-cavity flashing
5. Sheathing tape at all laps in sheathing membrane **(AB)**

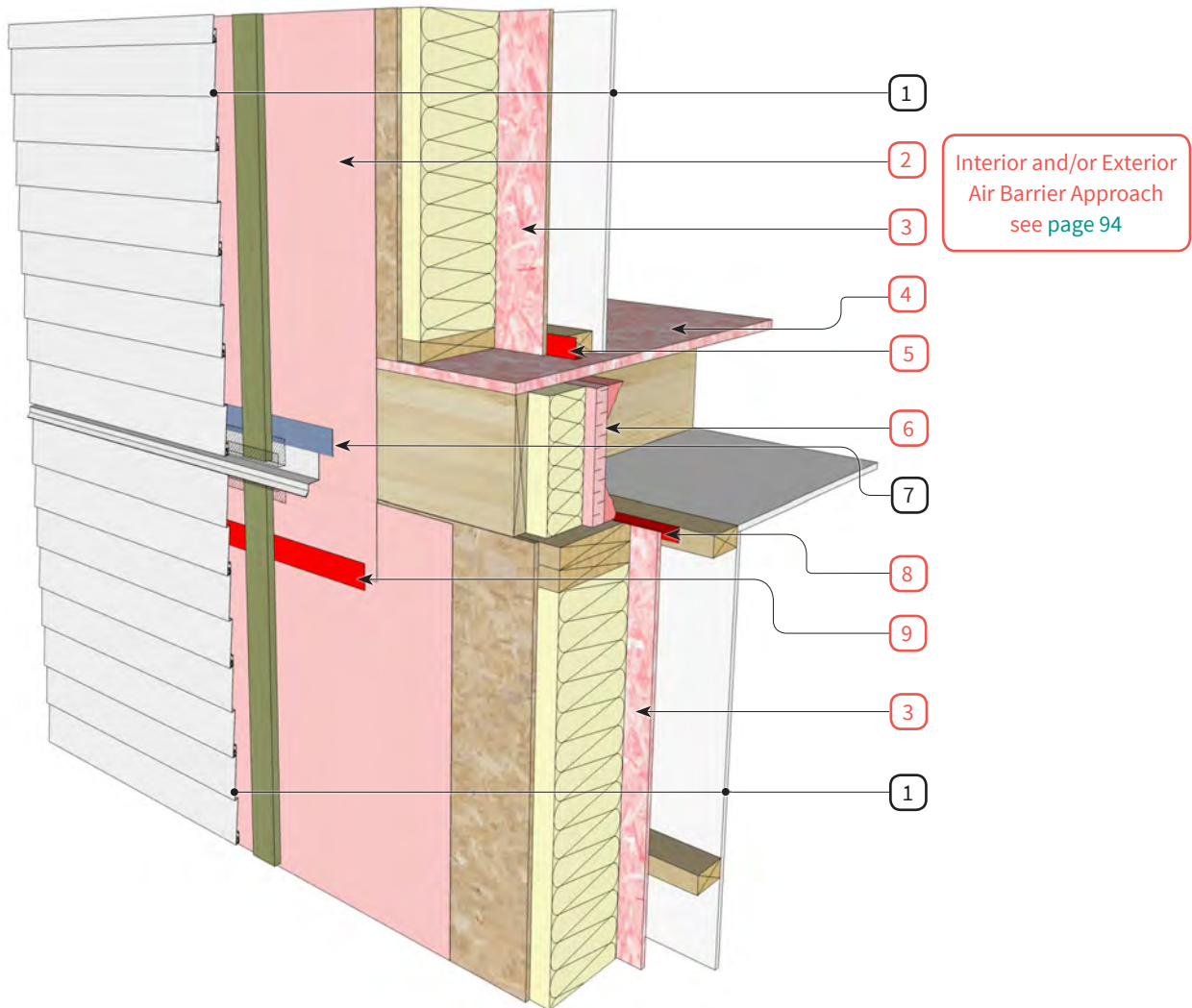
Detail 20**Deep Stud-Insulated Wall at Rim Joist**

1. Deep stud-insulated wall assembly with service cavity, see [page 62](#)
2. Vapour-permeable sheathing membrane (AB)
3. Interior wall sheathing (AB)
4. Interior floor sheathing (AB)
5. Tape between interior wall sheathing and interior floor sheathing (AB)
6. Extruded polystyrene insulation with closed-cell spray foam at edges (AB)
7. Sheathing tape over top edge of cross-cavity flashing
8. Tape over wall top plate and down interior wall sheathing (AB)
9. Sheathing tape at all laps in sheathing membrane (AB)

Detail 21 Stud-Insulated Wall at Supported Balcony

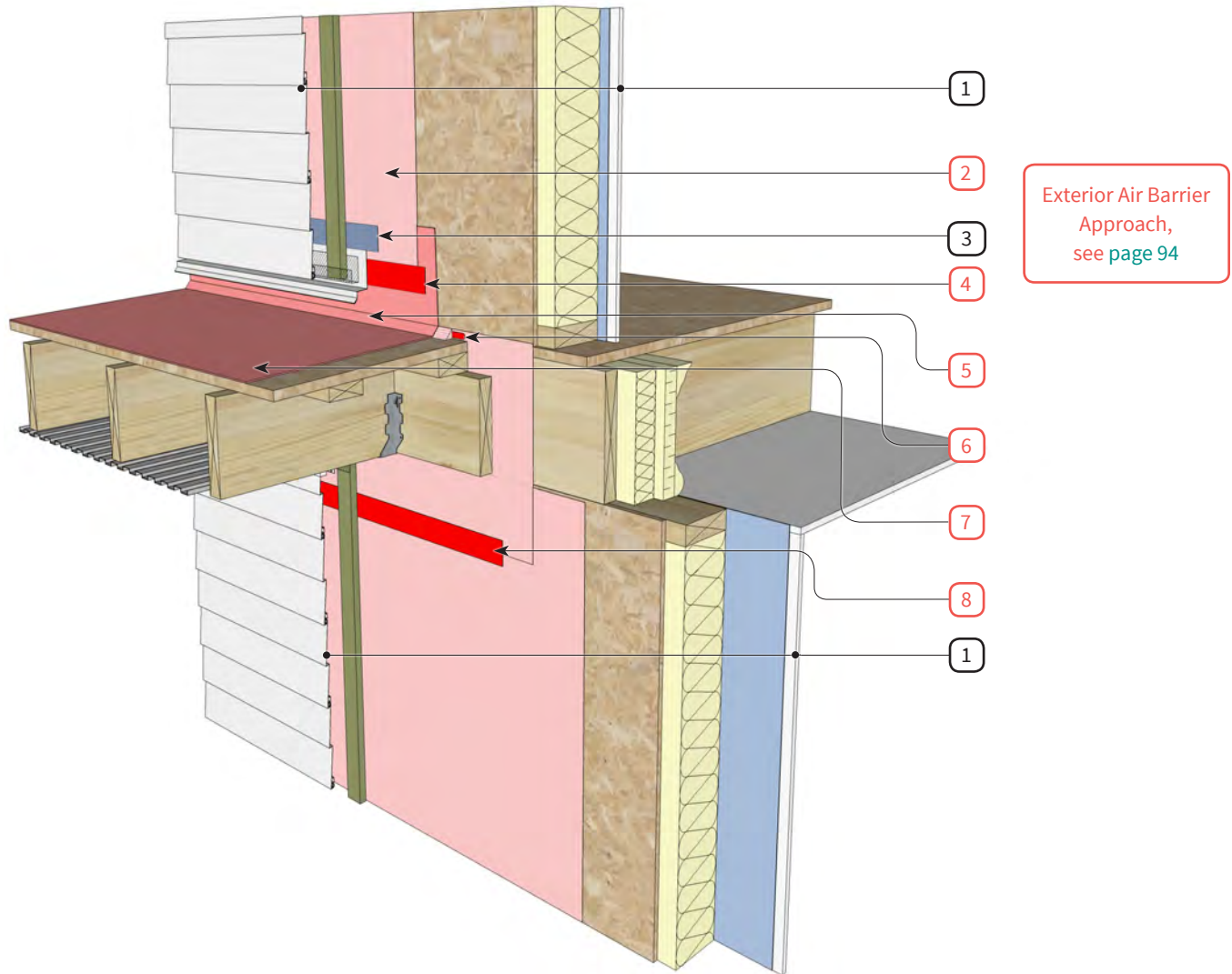

1. Stud-insulated wall assembly, see [page 56](#)
2. Vapour-permeable sheathing membrane (AB)
3. Sheathing tape over top edge of base of wall flashing
4. Tape between sheathing membrane lapped over balcony membrane (AB)
5. Cant strip beneath balcony membrane at transition from balcony surface to base of wall (AB)
6. Cant strip sealed to termination of sheathing membrane at balcony surface (AB)
7. Balcony membrane (AB)
8. Sheathing tape at all laps in sheathing membrane (AB)

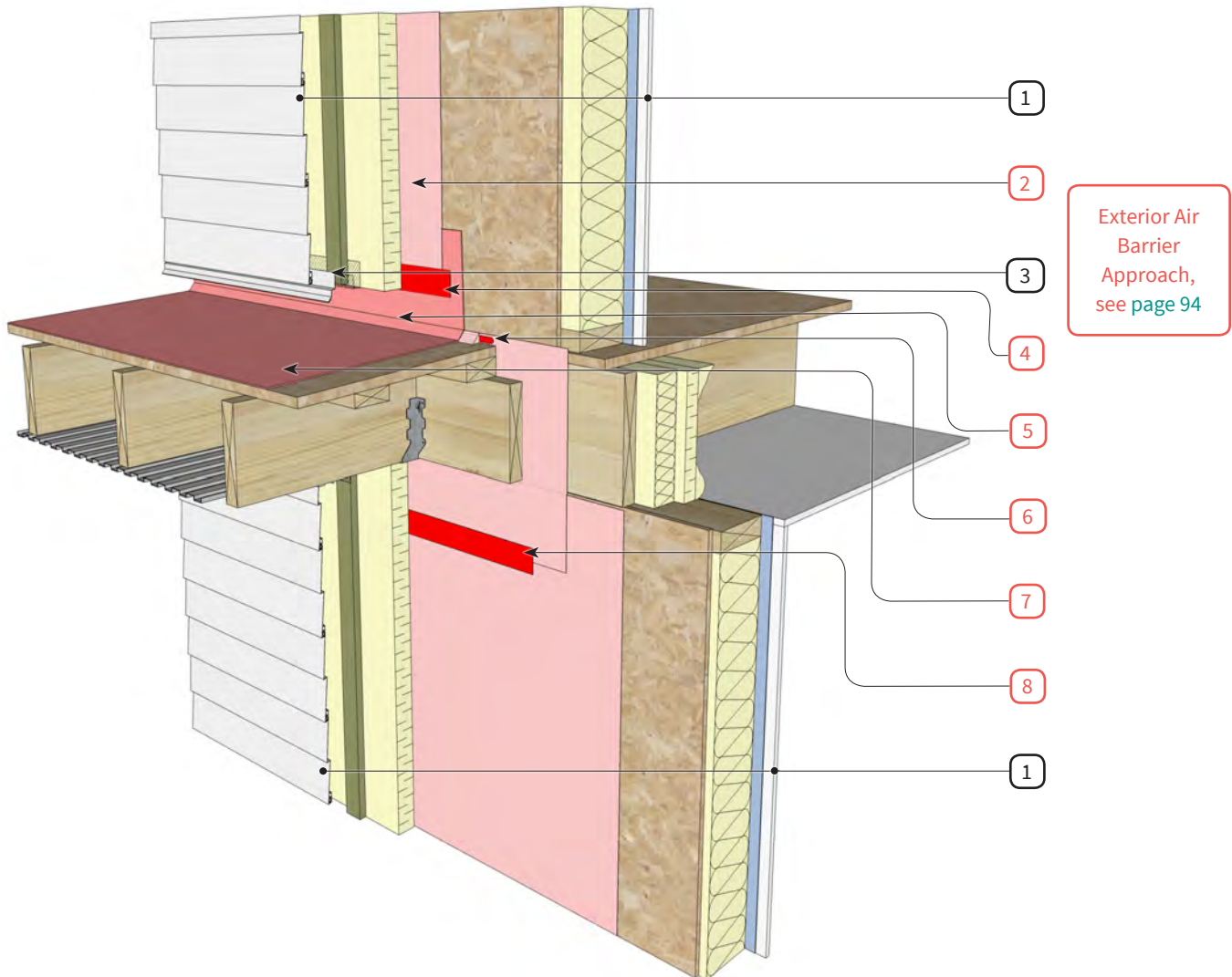
Detail 22**Split-Insulated Wall with Thin Exterior Insulation at Supported Balcony**

1. Split-insulated wall assembly, see [page 58](#)
2. Vapour-permeable sheathing membrane (AB)
3. Base of wall flashing fastened to furring strips
4. Tape between sheathing membrane lapped over balcony membrane (AB)
5. Cant strip beneath balcony membrane at transition from balcony surface to base of wall (AB)
6. Cant strip sealed to termination of sheathing membrane at balcony surface (AB)
7. Balcony membrane (AB)
8. Sheathing tape at all laps in sheathing membrane (AB)

Detail 23 Deep Stud Wall at Supported Balcony

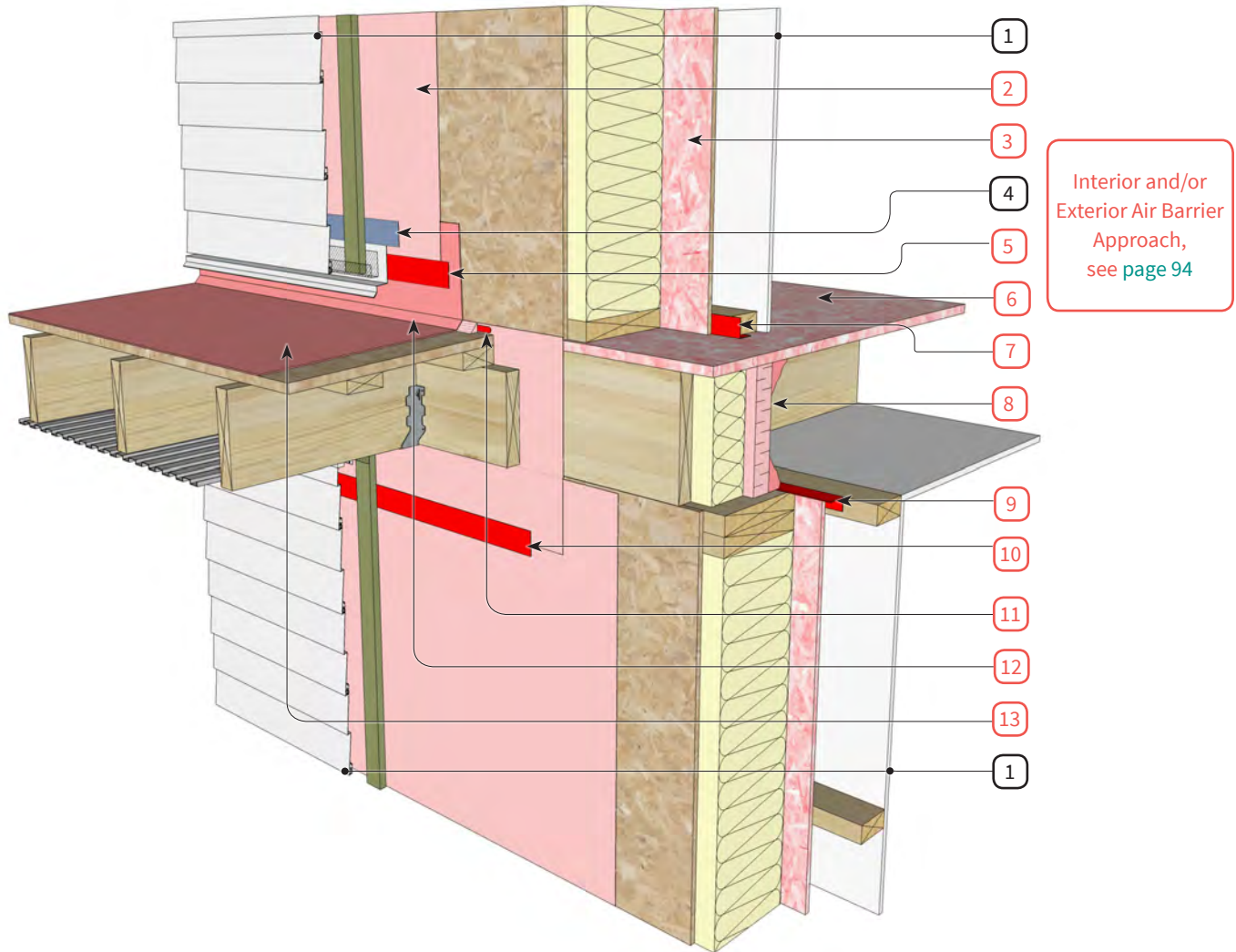

1. Deep stud-insulated wall assembly with service cavity, see [page 62](#)
2. Vapour-permeable sheathing membrane (AB)
3. Interior wall sheathing (AB)
4. Sheathing tape over top edge of base of wall flashing
5. Tape between sheathing membrane lapped over balcony membrane (AB)
6. Interior floor sheathing (AB)
7. Tape between interior wall sheathing and interior floor sheathing (AB)
8. Extruded polystyrene insulation with closed-cell spray foam at edges (AB)
9. Tape over wall top plate and down interior wall sheathing (AB)
10. Sheathing tape at all laps in sheathing membrane (AB)
11. Cant strip sealed to termination of sheathing membrane at balcony surface (AB)
12. Cant strip beneath balcony membrane at transition from balcony surface to base of wall (AB)
13. Balcony membrane (AB)

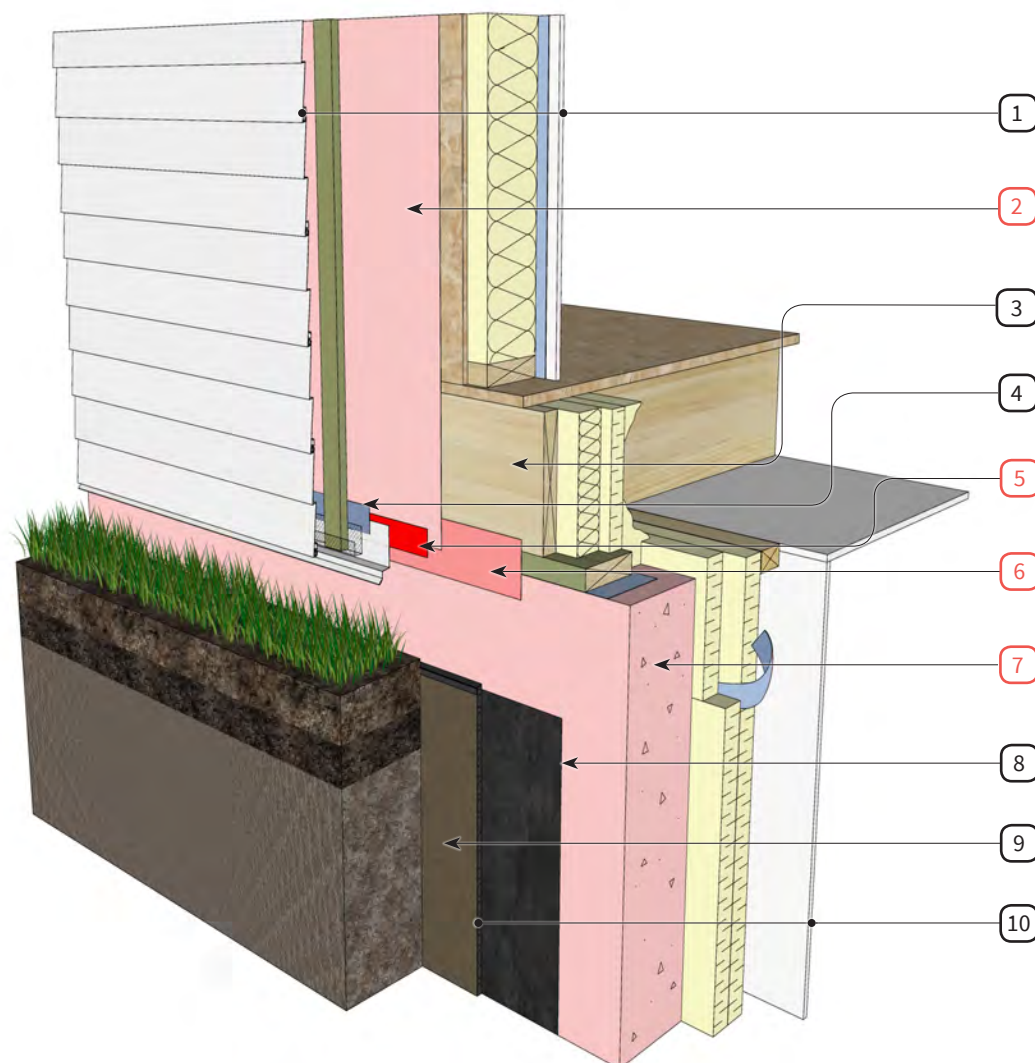
Detail 24**Transition Between Stud-Insulated Wall and Interior-Insulated Foundation Wall**

1. Stud-insulated wall assembly, see [page 56](#)
2. Vapour-permeable sheathing membrane (AB)
3. Rim joist
4. Sheathing tape over top edge of base of wall flashing
5. Sheathing tape at sheathing membrane termination over impermeable self-adhered membrane strip (AB)
6. Self-adhered membrane strip or tape between rim joist and concrete foundation wall (AB)
7. Concrete foundation wall (AB)
8. Dampproofing or waterproofing
9. Drain mat
10. Interior-insulated foundation wall assembly, see [page 81](#)

Taped
Membrane
Approach,
see [page 105](#)

Detail 25

Transition Between Split-Insulated Wall with Thin Exterior Insulation and ICF Foundation Wall

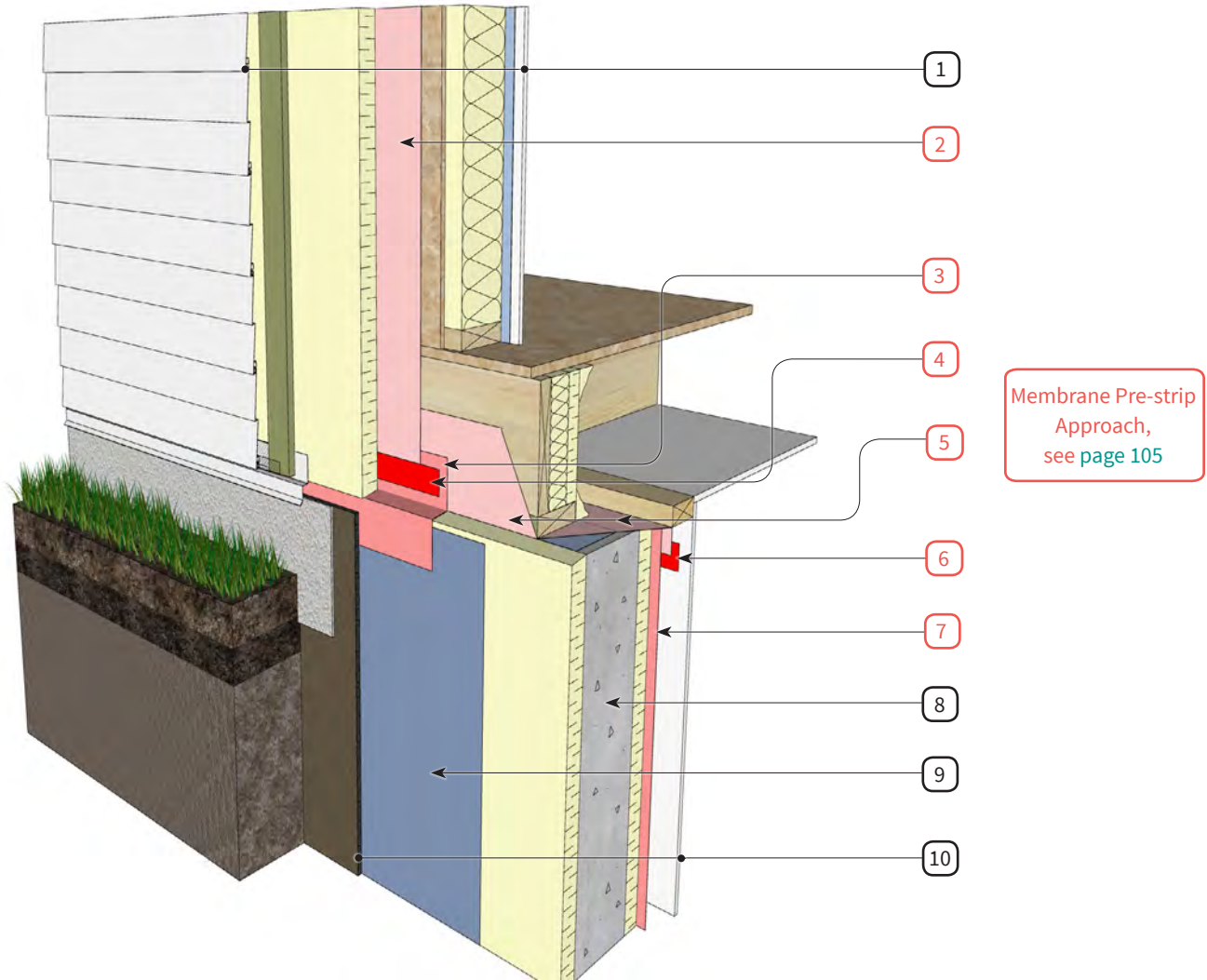

1. Split-insulated wall assembly, see [page 58](#)
2. Vapour-permeable sheathing membrane AB
3. Self-adhered flashing membrane over top edge of ICF foundation wall and dampproofing/ waterproofing AB
4. Sheathing tape between wall sheathing membrane and base of wall flashing membrane AB
5. Sheathing membrane transition strip from rim joist to interior of ICF foundation wall AB
6. Sheathing tape at lap between sheathing membrane transition strip and interior sheathing membrane AB
7. Interior sheathing membrane AB
8. ICF foundation wall
9. Dampproofing or waterproofing
10. ICF foundation wall assembly see [page 82](#)

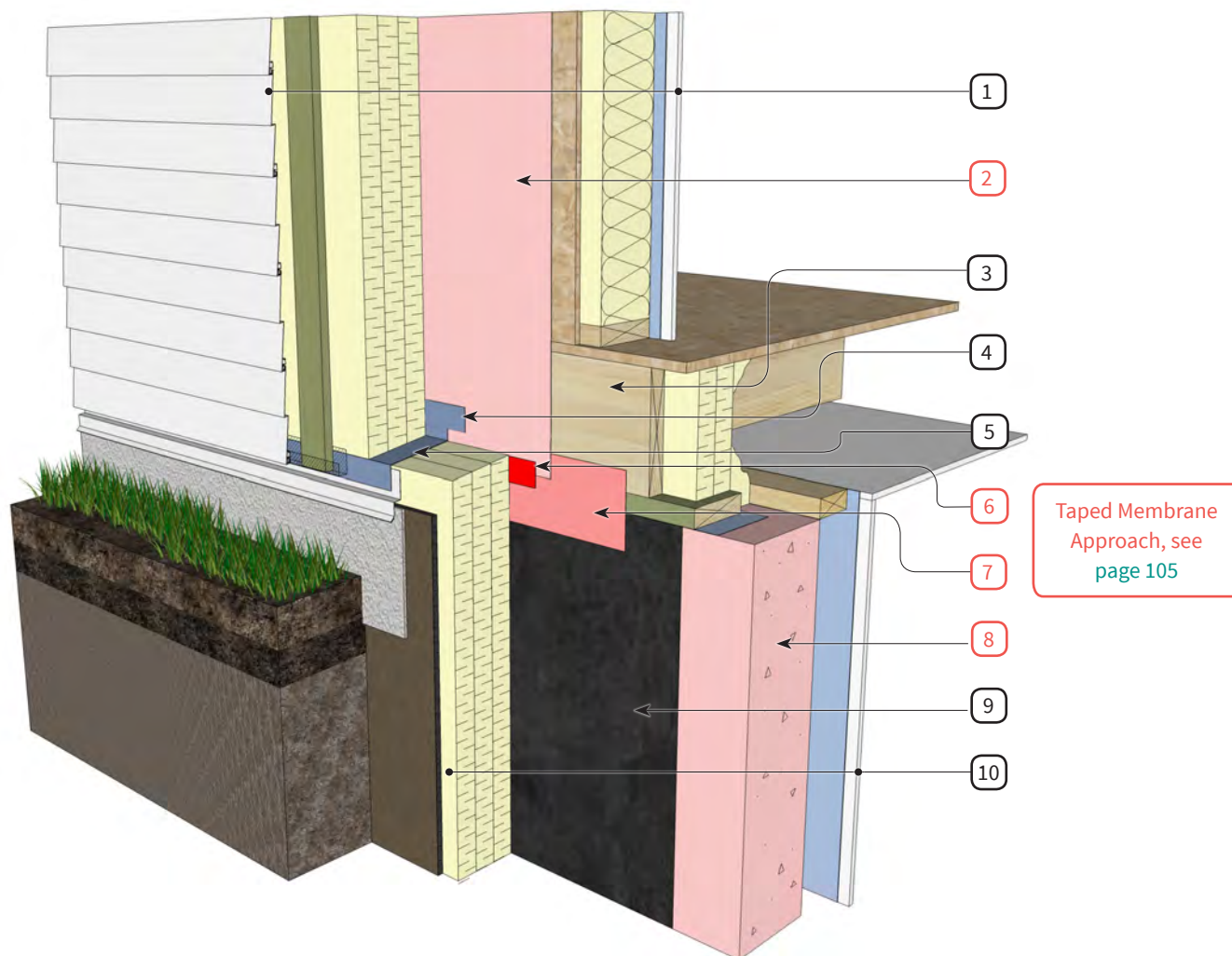
Detail 26**Transition Between Split-Insulated Wall with Thick Exterior Insulation and Exterior-Insulated Foundation Wall**

1. Split-insulated wall assembly, see [page 60](#)
2. Vapour-permeable sheathing membrane **(AB)**
3. Rim joist
4. Sheathing tape over top edge of base of wall flashing membrane
5. Thermally broken through-wall flashing;
Self-adhered flashing membrane on sloped insulation over top edge of base of wall flashing
6. Sheathing tape at sheathing membrane termination **(AB)** over self-adhered membrane strip
7. Self-adhered membrane strip between rim joist and concrete foundation wall dampproofing/ waterproofing **(AB)**
8. Concrete foundation wall **(AB)**
9. Dampproofing or waterproofing
10. Exterior-insulated foundation wall assembly, see [page 80](#)

Detail 27

Transition Between Deep Stud-Insulated Wall and Interior-Insulated Foundation Wall

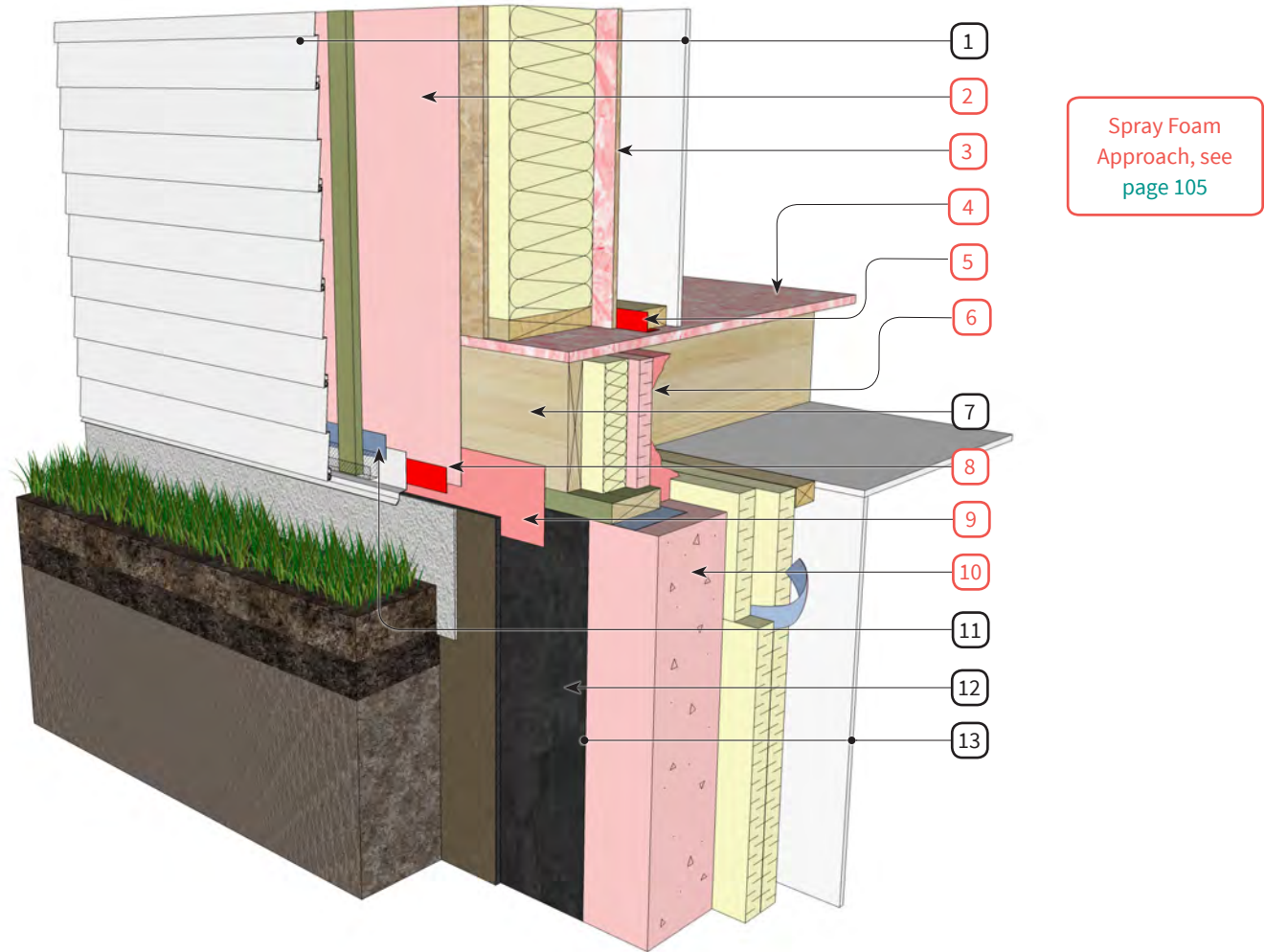

1. Deep stud-insulated wall assembly with service cavity, see [page 62](#)
2. Vapour-permeable sheathing membrane (AB)
3. Interior wall sheathing (AB)
4. Interior floor sheathing (AB)
5. Tape between interior wall sheathing and interior floor sheathing (AB)
6. Extruded polystyrene insulation with closed-cell spray foam at edges (AB)
7. Rim joist
8. Sheathing tape at sheathing membrane termination over self-adhered membrane strip (AB)
9. Self-adhered membrane strip between rim joist and concrete foundation wall dampproofing or waterproofing (AB)
10. Concrete foundation wall (AB)
11. Sheathing tape over top edge of base of wall flashing
12. Dampproofing or waterproofing
13. Interior-insulated foundation wall assembly, see [page 81](#)

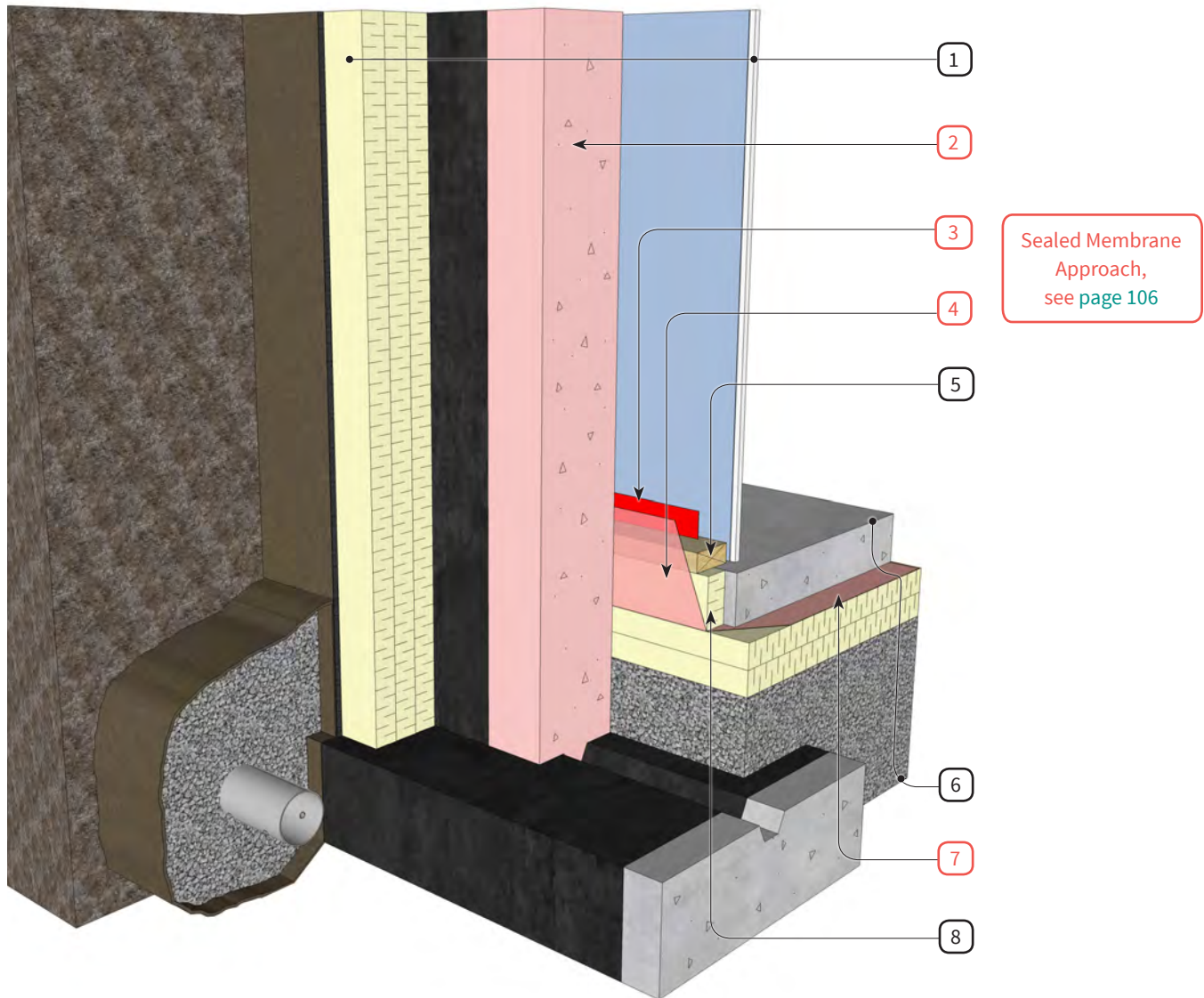
Detail 28**Transition Between Exterior-Insulated Foundation Wall and Exterior-Insulated Slab**

1. Exterior-insulated foundation wall assembly, see [page 80](#)
2. Concrete foundation wall AB
3. Tape at polyethylene sheet membrane termination onto concrete foundation wall AB
4. Polyethylene sheet membrane behind slab edge insulation onto concrete foundation wall AB
5. Wall bottom plate
6. Exterior-insulated concrete slab assembly, see [page 84](#)
7. Polyethylene sheet membrane AB
8. Extruded polystyrene slab edge insulation

Detail 29

Transition Between Interior-Insulated Foundation Wall and Exterior-Insulated Slab

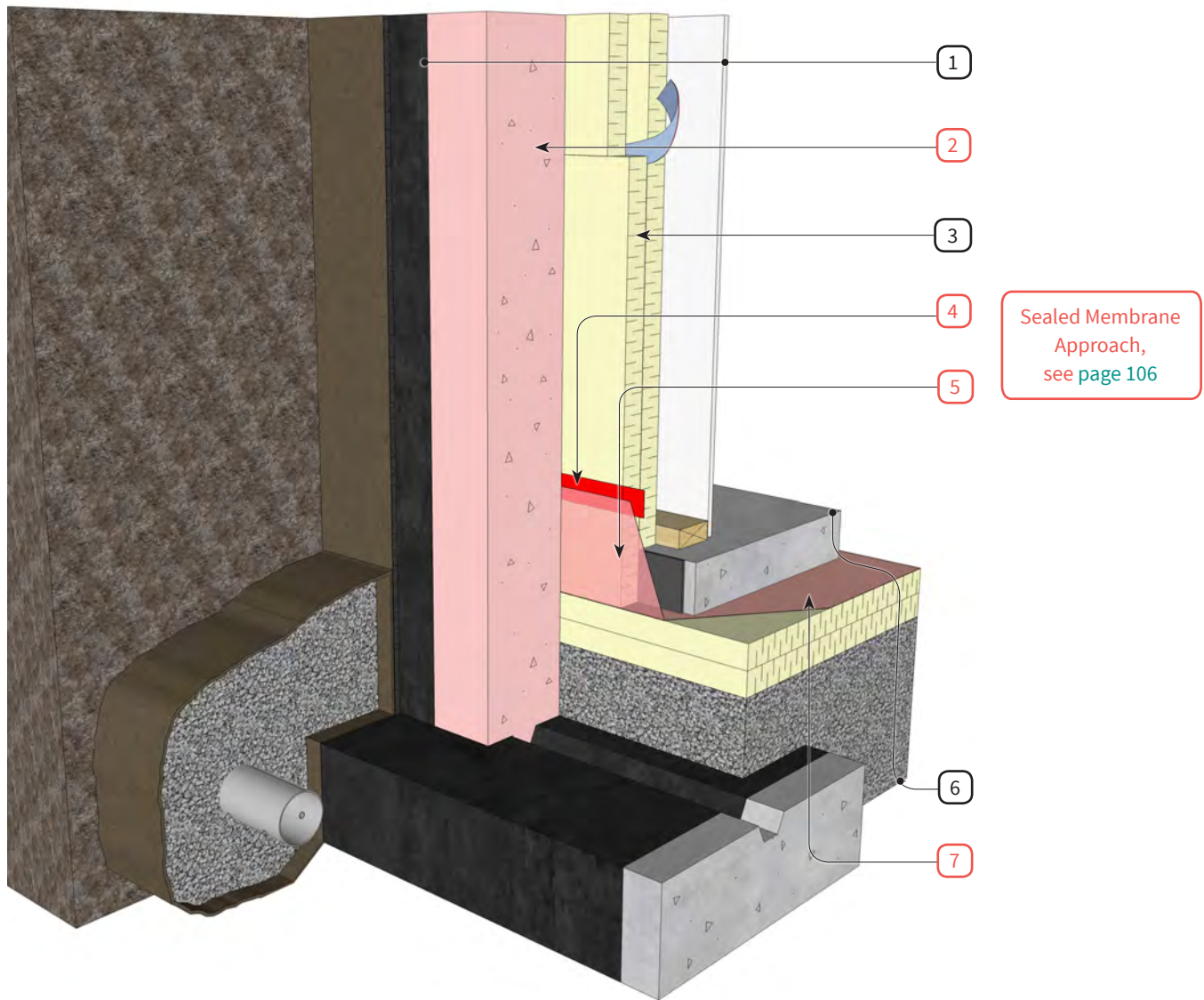

1. Interior-insulated foundation wall assembly, see [page 81](#)
2. Concrete foundation wall AB
3. Extruded polystyrene interior foundation wall and slab edge insulation
4. Tape at polyethylene sheet membrane termination AB
5. Polyethylene sheet membrane run behind AB slab edge insulation onto concrete foundation wall
6. Exterior-insulated concrete slab assembly, see [page 84](#)
7. Polyethylene sheet membrane AB

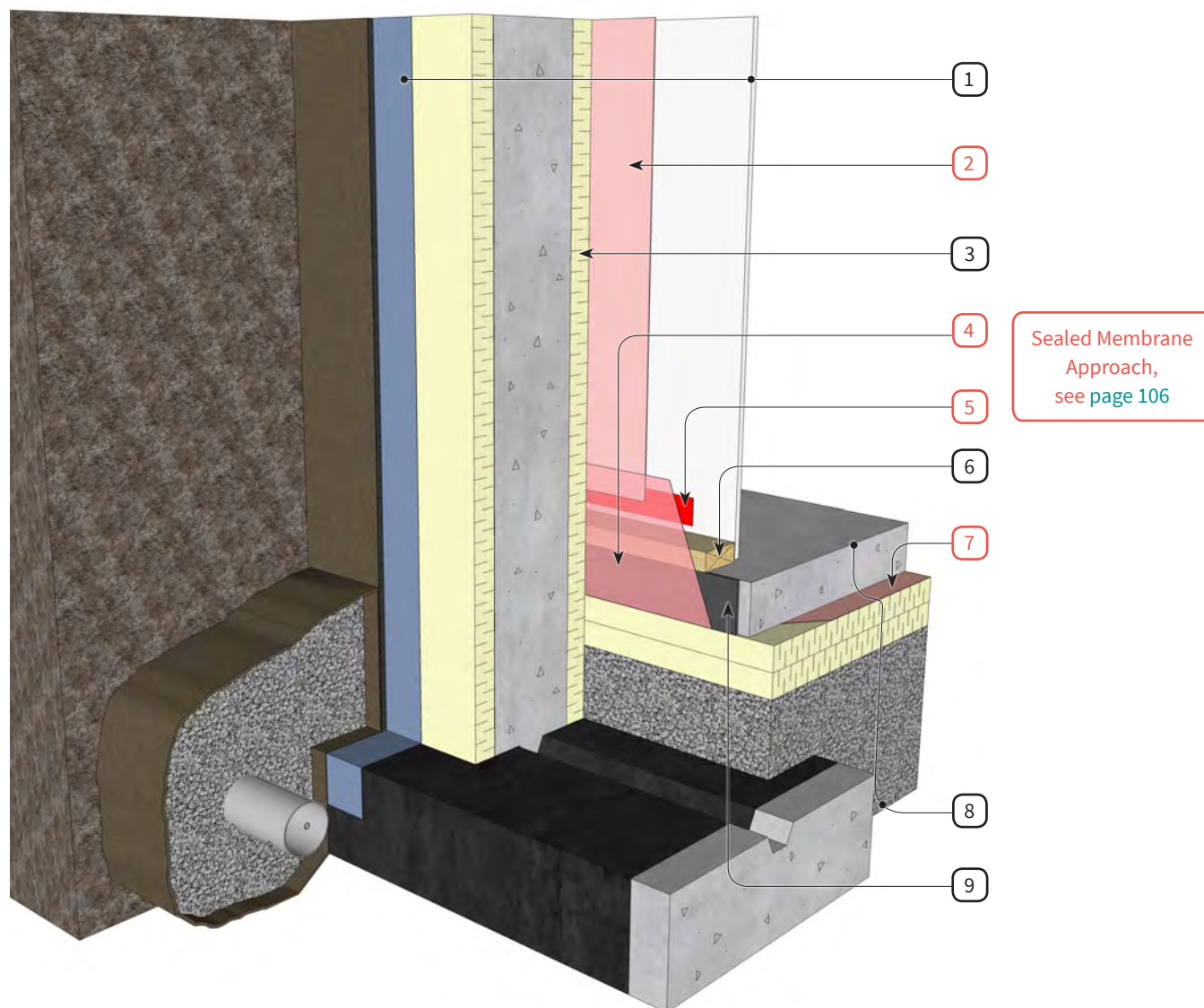
Detail 30**Transition between ICF Foundation Wall and Exterior-Insulated Slab**

1. ICF foundation wall assembly, see [page 82](#)
2. Interior sheathing membrane **(AB)**
3. ICF foundation wall insulation
4. Polyethylene sheet membrane run behind slab edge bond break and wall bottom plate onto ICF foundation wall insulation **(AB)**
5. Tape between sheathing membrane termination onto polyethylene sheet membrane **(AB)**
6. Wall bottom plate
7. Polyethylene sheet membrane **(AB)**
8. Exterior-insulated concrete slab assembly, see [page 84](#)
9. Slab edge bond break

This page is intentionally left blank

Additional Resources

BC Energy Step Code

BC Energy Step Code website - energystepcode.ca

BC Energy Step Code Design Guide published by BC Housing - bchousing.org

Guides

Published by BC Housing (bchousing.org/research-centre/library):

Building Enclosure Design Guide

Illustrated Guide - Achieving Airtight Buildings

Illustrated Guide - Energy Efficiency Requirements for Houses in BC

Illustrated Guide - R22+ Effective Walls in Residential Construction in BC

Residential Construction Performance Guide

Builder's Guide to Cold Climates published by Building Science Corporation
buildingscience.com

Canadian Home Builder's Association Builders' Manual published by the
Canadian Home Builders' Association - chba.ca

Guide for Designing Energy-Efficient Building Enclosures for Wood-Frame
Multi-Unit Residential Buildings published by FPInnovations, BC Housing,
and the Canadian Wood Council - fpinnovations.ca

Pathways to High-Performance Housing in British Columbia published by
FPInnovations - fpinnovations.ca

Energy Modelling Guidelines published by the City of Vancouver
vancouver.ca

Research/Reports

Energy Step Code 2018 Metrics Research Full Report Update, published by BC Housing - energystepcode.ca

Study of Part 3 Building Airtightness published by the National Research Council of Canada, available from rdh.com



Building Science Digest-014: Air Flow Control in Buildings published by Building Science Corporation - buildingscience.com

Building Science Digest-104: Understanding Air Barriers published by Building Science Corporation - buildingscience.com

Towards Airtightness - The Contractor's Role in Designing and Constructing the Air Barrier System published from the Building Enclosure Science & Technology 3 Conference, available from walshconstructionco.com

Attic Ventilation and Moisture Research Study published by BC Housing bchousing.org



Glossary of Terms

% < REF	% Lower than Reference House; A Step Code performance metric used to determine the energy performance of a building in relation to a modelled building benchmark, referred to by the BC Building Code as a reference building. Reference buildings are based on whole building energy analysis using energy simulation software.
	
Adhesion	The binding of two surfaces by adhesive forces.
Air Barrier	Materials and components which control the airflow through building enclosures to limit the potential for heat loss and condensation .
Air Leakage Rate/Airtightness	Air leakage rate is the quantitative measurement representing how much air leaks through the building enclosure. Airtightness is the common term for describing the continuity of the building air barrier system. The lower the air leakage rate, the greater the airtightness. For buildings in BC, increasing airtightness is one of the most cost-effective ways to reduce building energy consumption. Airtightness is measured by airtightness testing .
	
Airtightness Testing	A test using blower fans to pressurize and/or depressurize the building, with the goal of measuring the building enclosure air leakage rate . Better airtightness testing results indicate a more continuous air barrier system. Airtightness testing is a requirement for all Steps of the BC Energy Step Code.
Authority Having Jurisdiction (AHJ)	The provincial organization, office or individual responsible for adopting and enforcing the laws and regulations of construction.
Backer Rod	A cylindrical foam material, either polyethylene or polyurethane, that is used to control sealant joint depth, provide a surface for sealant tooling, serve as a bond breaker to prevent three sided adhesion, and provide an “hour-glass” control of the finished sealant profile.
Balcony	An outdoor horizontal surface, intended for pedestrian use, which projects from a building and is neither located over a living space nor acts as a roof.
BC Energy Step Code	The section of the BC Building Code which sets the energy efficiency requirements for new buildings. It uses tiers of performance targets, rather than prescriptive requirements.
Bottom Plate	The lower horizontal member of a wood-framed wall on which the bottom of a stud rests.
Building Enclosure	A system of materials, components and assemblies which physically separates the interior environment of a building from the outdoors. Its components should be designed to ensure the control of air and heat flow through the building enclosure in addition to the control of water, water vapour, sound, fire, and smoke.

Built Environment	A general term referring to the human-made surroundings that provide the setting for human activity, ranging in scale from individual buildings to complete transportation systems.
Bulk Water Ingress	The act of liquid water entering the building enclosure, or passing through to another location where its presence is not desired.
Cant Strip	A strip of material of triangular section placed at the intersection of a balcony or roof deck with a higher wall or other vertical surface for making smooth transitions for membranes.
Capillary Break	An air space or material in an assembly which hinders capillary action, decreasing the potential for water movement between materials.
Casement Window	A window which opens on a hinge to the left or right.
Cladding	A material or component of the wall assembly that forms the outer surface of the wall and is exposed to the full force of the environment. Also referred to as siding.
Coefficient of Performance (COP)	The unit used to measure heat pump efficiencies. For example, a 300% efficiency correlates to a COP of 3.0
Condensation	The appearance of moisture (water vapour) on a surface caused by air encountering a surface that is at, or below, the dew point temperature of the air.
Conductivity	A measure of the ability of a material to transmit heat (a process known as conduction).
Convective Looping	A process which can occur if there is excessive void space in assemblies enabling air to flow; warm air rises until it is thermally depleted. The now cooled air begins to sink, gathering thermal energy and creating a loop of rising and falling air – a convective loop. This can reduce insulation effectiveness and contribute to moisture accumulation within the assembly.
Dew Point Temperature	The temperature at which air is saturated with water vapour (100% relative humidity). Adjacent surfaces at temperatures lower than the dew point temperature of the air will lead to the formation of condensation .
Domestic Hot Water (DHW)	Hot water used within a building. The heating of which usually accounts for 15-35% of a buildings energy use. Typically heated by a gas boiler or electric coil then stored for later use; can also be heated through tankless instantaneous heating.
Drain Water Heat Recovery	A mechanism which collects the heat from used drain water and uses it to assist in the heating of supply water.

Electric Baseboard	A common heating system which generates heat by electrical resistance in a heating element and distributes the heat via radiating fins. They can be operated individually and are 100% efficient.
Enclosure-First Approach	An approach to reduce energy consumption and provide a comfortable indoor environment for the occupants. A key strategy in achieving high-performance buildings .
Energy Factor	A metric used to compare the energy conversion efficiency of appliances and equipment.
Energy Recovery Ventilator (ERV)	An electrical energy saving device, like an HRV , included in most high-performance homes which recovers heat from air leaving the building using a passive heat exchanger. It also controls the transfer of moisture to help maintain the buildings humidity levels.
Enthalpy Core	A specialized heat exchanger which allows both heat and moisture transfer between air streams without cross-contamination. See ERV .
Equipment Operating Efficiency	A measurement for the efficiency at which input energy is converted into useful output energy.
Fenestration	The non-opaque components of a building used for light transfer and visibility such as windows, door sidelights and skylights.
Flashing	The material used to prevent water penetration or direct the flow of water at interfaces and joints between construction assemblies.
Framing Factor	The percent composition of the framed portion of a wall assembly that consists of framing members rather than insulation or other materials. For all effective R-values in the guide, calculations are based upon a framing factor corresponding to standard framing practices for 16” spaced members.
Gasket	A seal meant to prevent the leakage of liquid or gas, usually made of rubber or a rubber-like material.
Glazing	The glass components of the building enclosure, most often found in windows and doors.
Greenhouse Gas Intensity (GHGI)	An additional metric for rezoning requirements by the City of Vancouver, not in the BC Energy Step Code . GHGI is the total green house gas emissions associated with the use of all energy utilities on site. It is expressed in kg CO ₂ e/ (m ² year).
 Greenhouse Gas Intensity (GHGI)	An additional metric for rezoning requirements by the City of Vancouver, not in the BC Energy Step Code . GHGI is the total green house gas emissions associated with the use of all energy utilities on site. It is expressed in kg CO ₂ e/ (m ² year).
Head	The horizontal wooden member that forms the top of a window frame.

Heat Pump	A device that circulates refrigerant which absorbs and releases heat through evaporation and condensing of the refrigerant as it travels between the indoors and the outdoors. Can provide heating or cooling.
Heat Recovery Ventilator (HRV)	An electrical energy saving device included in most high-performance homes which recovers heat from air leaving the building using a passive heat exchanger.
High-Performance Building	A building built to high energy-efficient standards with reduced energy needs compared to today's standards.
Heating, Ventilation and Air Conditioning (HVAC)	The systems used to actively control the interior conditions of a building.
Hydrostatic Pressure	The force exerted by water on an object or material caused by gravitational forces on the water.
Insulating Concrete Forms (ICF)	Manufactured interlocking modular concrete formwork made of expanded polystyrene (EPS) insulation which are filled with concrete after assembly.
Insulating Glass Unit (IGU)	Consists of multiple panes of glass separated by spacer bars, sealed together with a waterproof and airtight sealant. The thermal performance of IGUs can be improved by filling the space between panes with an inert gas, and by including one or more low-e coatings on select window panes.
Internal Heat Gains	Heat generated by the equipment or living occupants within a building which contribute to the internal thermal load of a space.
Jamb	The vertical framing members which make up the sides of window and door frames.
Low-e Coating	Low-emissivity coatings, which are commonly applied to a glass surface, reduce radiation heat transfer and improve the window's thermal performance (U-value).
Makeup Air System (MUA)	A system which uses a central supply fan, also known as a makeup air unit (MUA), and ductwork to provide ventilation air throughout a building. Incoming air is conditioned to the correct temperature before it is supplied to the building.
Massing	Refers to the three-dimensional form of a structure. It helps influence the sense of a buildings volume and ratios compared to its context. It helps define both the interior space and exterior shape of a building.

Mechanical Energy Use Intensity (MEUI)	A performance metric for the equipment and systems of Part 9 buildings that varies depending on building size and whether the building has incorporated mechanical cooling. It considers the energy consumption by HVAC systems and their auxiliary equipment. MEUI omits base load energy consumption.
	
Net-Zero Energy Ready Building	A building built to high energy-efficient standards such that it could, with additional measures, generate enough on-site energy to meet its own energy needs.
Opaque Assembly	The components of the building enclosure which light does not pass through (i.e. Insulation, sheathing, studs).
Parapet	A low wall along the edge of a flat roof.
Part 3 Buildings	In the context of this Step Code guide, residential buildings over three storeys in height or over 600 square metres in footprint. Part 3 buildings may also be determined by use (i.e. type of occupancy).
	
Part 9 Buildings	In the context of this Step Code guide, residential buildings three storeys and under in height and with a footprint of 600 square metres or less. This includes small residential buildings such as single-family detached homes and small apartment complexes.
	
Penetration	An intentional opening through an assembly to allow for ducts, electrical wires, pipes, and fasteners to pass through.
Performance Path	Designing a building to comply with the parameters defined in BCBC Subsection 9.36.5 which requires energy modelling to be carried out such that the house is designed to achieve the same energy performance as a reference house designed using Subsections 9.36.2 to 9.36.4.
Permeability	A measure of the ability of a material to allow water (liquid or gas) to pass through it.
Pre-stripping	A material installed early during the construction sequence of an assembly, typically for air or moisture control.
Polyethylene Sheet	A type of plastic sheet commonly used to prevent vapour and air from moving through an assembly.
Prescriptive Path	Designing a building to comply with the prescriptive requires defined in BC Building Code (BCBC) subsections 9.36.2 to 9.36.4 which uses performance targets based on metrics such as R-values and U-Values .

Rainscreen Cavity	A small air space incorporated between the exterior cladding and the rest of the wall assembly, meant to promote drainage and drying of any water that is present behind the cladding .
Reference House	See %<REF
Relative Humidity (RH)	The ratio of the amount of water vapour in a volume of air to the maximum amount of water vapour it can hold at a given temperature. Often expressed in percentages. For example, fully saturated air is at 100% relative humidity.
R-Value	The Imperial measurement of a material's thermal resistance to conductive heat flow, often used to describe different types of insulation. Higher values indicate greater insulating capabilities. The inverse of U-value .
RSI-Value	The Metric measurement of a material's thermal resistance to conductive heat flow, often used to describe different types of insulation. Higher values indicate greater insulating capabilities. The inverse of USI-value .
Sewage Heat Recovery	A type of heat pump system which extracts heat from waste water. Mainly used in larger residential buildings.
Sheathing Membrane	A material in an exterior wall assembly that limits the penetration of water further into the structure past the cladding . These materials include both vapour-permeable sheathing membranes, such as sheathing paper and housewraps, and waterproof (non-vapour permeable) sheathing membranes, such as self-adhesive modified bituminous membranes.
Sliding Window	A window which opens by sliding on a track. They are more prone to air and thermal leakage than casement windows .
Soil Gas Mitigation System	A system in place to prevent harmful gases found in soil such as radon or methane, from passing through the building enclosure to the building's interior.
Solar Heat Gain Coefficient (SHGC)	The fraction of solar radiation admitted through a window, both directly transmitted and absorbed, and subsequently released inward. The lower a window's SHGC, the less solar heat it transmits.
Stack Effect Pressure	The movement of air into and out of buildings, chimneys, or other containers, resulting from air buoyancy. This occurs due to a difference in indoor and outdoor air density, resulting from temperature and moisture differences.
Stud	The vertical framing member used in succession in walls and partitions.
Substrate	A material or surface which acts as a base, on top of which additional materials or surfaces are fastened or adhered.

Thermal Break	A material with low conductivity that is placed between two conductive materials, such as a metal frame, to reduce heat flow and decrease condensation potential.
Thermal Bridging	The transfer of heat that occurs through a material with thermal conductivity higher than that of the surrounding materials. A common example is a stud within an insulated wall.
Thermal Cycling	The stress placed on a material from expansion and contraction caused by seasonal thermal changes in the surrounding environment.
Thermal Energy Demand Intensity (TEDI)	A Step Code performance metric for the annual heating energy demand for space conditioning and ventilation air, per unit of floor area (kWh/m ²). Energy used to heat domestic hot water, for example, is not included in the TEDI.
	
Top Plate	The upper horizontal member(s) of a wood-framed wall on which floor framing or the roof framing rests.
Total Energy Use Intensity (TEUI)	A Step Code performance metric for the equipment and systems of Part 3 buildings. It considers the energy consumption from the enclosures' HVAC systems, base loads and auxiliary HVAC equipment.
	
U-Value	The Imperial measure of the conductive heat transmission property of a material or assembly of materials, expressed as a rate of heat flux through a material. Lower values indicate greater insulating capabilities. The inverse of R-value .
USI-Value	The Metric measure of the conductive heat transmission property of a material or assembly of materials, expressed as a rate of heat flux through a material. Lower values indicate greater insulating capabilities. The inverse of RSI-value .
Vapour Retarder	A material with low vapour permeability that is located within the assembly to control the flow of vapour.
Water-Resistive Barrier	A material typically located towards the exterior of an assembly which protects the moisture-sensitive parts of the assembly from liquid water.
Water-Shedding Surface	The exterior surface of assemblies, interfaces, and details that deflect and drain most of the liquid water which the building is exposed to from the exterior environment.

Appendix A: Part 9 Step Code Compliance Report

Available from www.gov.bc.ca

PRE-CONSTRUCTION

BC ENERGY COMPLIANCE REPORT - PERFORMANCE PATHS FOR PART 9 BUILDINGS

For Buildings Complying with Subsection 9.36.5. or 9.36.6. of the 2012 BC Building Code (see BCBC Article 2.2.8.3. of Division C)

A: PROJECT INFORMATION

Building Permit #: _____ **Building Type:** Please Select Building Type
Builder: _____ **If Other, Please Specify:** _____
Project Address: _____ **Number of Dwelling Units:** _____
Municipality / District: _____ **Climate Zone:** Please Select Climate Zone
Postal Code: _____ **PID or Legal Description:** _____

BC Building Code Performance Compliance Path (select one):

9.36.5. ➔ Complete Sections A, B, C, & E
 9.36.6. ➔ Complete Sections A, B, D, & E

Software Name: _____ **Version:** _____ **Climatic Data (Location):** _____

B: BUILDING CHARACTERISTICS SUMMARY (see BCBC Clause 2.2.8.3.(2)(b) of Division C)

	DETAILS (ASSEMBLY / SYSTEM TYPE / FUEL TYPE / ETC.)	EFFECTIVE RSI-VALUE / EFFICIENCY
EXTERIOR WALLS & FLOOR HEADERS		
ROOF / CEILINGS		
FOUNDATION WALLS, HEADERS, & SLABS	Slab Is: <input type="checkbox"/> Below OR <input type="checkbox"/> Above Frost Line AND <input type="checkbox"/> Heated OR <input type="checkbox"/> Unheated	
FLOORS OVER UNHEATED SPACES		
FENESTRATION & DOORS	FDWR: _____ %	
AIR BARRIER SYSTEM & LOCATION		
SPACE CONDITIONING (HEATING & COOLING)		
SERVICE WATER HEATING		
VENTILATION		
OTHER ENERGY IMPACTING FEATURES		

The above information is correct based on drawings prepared by _____, dated (dd/mm/yyyy) _____.

VERSION 1.1 (DEC 6, 2017) 1

C: 9.36.5. ENERGY PERFORMANCE COMPLIANCE (see Clause 2.2.8.3.(2)(c) of Division C)

Complete this section only if using the Energy Performance Compliance Path in Subsection 9.36.5.

PROPOSED HOUSE RATED ENERGY CONSUMPTION (GJ/YEAR)		REFERENCE HOUSE RATED ENERGY TARGET (GJ/YEAR)	
HVAC		HVAC	
Hot Water Heating		Hot Water Heating	
SUM		SUM	

The airtightness value used in the energy model calculations for the Proposed House is:

4.5 ACH @ 50Pa 3.5 ACH @ 50Pa **OR** Tested At _____ ACH @ 50Pa

The above calculation was performed in compliance with Subsection 9.36.5. of Division B: Yes No

D: 9.36.6. ENERGY STEP CODE COMPLIANCE (see Sentence 2.2.8.3(3) of Division C)

Complete this section only if using the Energy Step Code Compliance Path in Subsection 9.36.6.

Proposed House Rated Energy Consumption (GJ/year): _____ Reference House Rated Energy Target (GJ/year): _____

METRIC	UNITS	REQUIRED	PROPOSED
Step Code Level	Step 1, 2, 3, 4, or 5		
Mechanical Energy Use Intensity (MEUI)	kWh/(m ² -year)	(max)	
ERS Rating % Lower Than EnerGuide Reference House, <i>where applicable</i>	%	(min)	
Thermal Energy Demand Intensity (TEDI)	kWh/(m ² -year)	(max)	
Peak Thermal Load (PTL)	W/m ²	(max)	
Airtightness in Air Changes per Hour at 50 Pa differential	ACH @ 50 Pa	(max)	
Step Code Design Requirements Met: <input type="checkbox"/>			

The above calculation was performed in compliance with (see Clause 2.2.8.3.(2)(e) of Division C)

Select One:

- Subsection 9.36.5.,
- The Passive House Planning Package (PHPP), version 9 or newer, and the energy model was prepared by a Certified Passive House Designer or Certified Passive House Consultant,
- The EnerGuide Rating System (ERS), version 15 or newer, or
- The applicable requirements of NECB Part 8 and the City of Vancouver Energy Modelling Guidelines.

E: COMPLETED BY

Full Name (Print): _____

Company Name: _____

Phone: _____

Address: _____

Email: _____

Date (dd/mm/yyyy): _____

If applicable, enter ERS information:

Advisor ID Number: _____

Service Organization: _____

EnerGuide P #: _____

SUPPLEMENTARY INFORMATION

Supplementary information is not required for Code Compliance but may be requested by the local municipality/district.

If required, complete the applicable sections below.

F: OTHER ENERGY MODELLING METRICS

METRIC	UNITS	PROPOSED
Airtightness NLA@10Pa	cm ² /m ²	
EnerGuide Rating	GJ/year	
EnerGuide Reference House	GJ/year	
EnerGuide Rating % Lower Than EnerGuide Reference House House with baseloads	%	
Rated Energy Intensity	GJ/m ² /year	
Rated Greenhouse Gas Emissions	kg/year	
Rated Greenhouse Gas Intensity	kg/m ² /year	

G: OPTIONAL CERTIFICATIONS

PENDING:

BUILTGREEN®, Level: _____

Certified Passive House

CHBA Net Zero House

ENERGY STAR® for New Homes

LEED® Canada for Homes, Level: _____

R2000

Other: _____

Appendix B: Example Step Code Flow Chart

The following example Step Code flow chart is for the City of Richmond.

How the Energy Step Code fits into the Building Permit Process for new Part 9* Residential Development

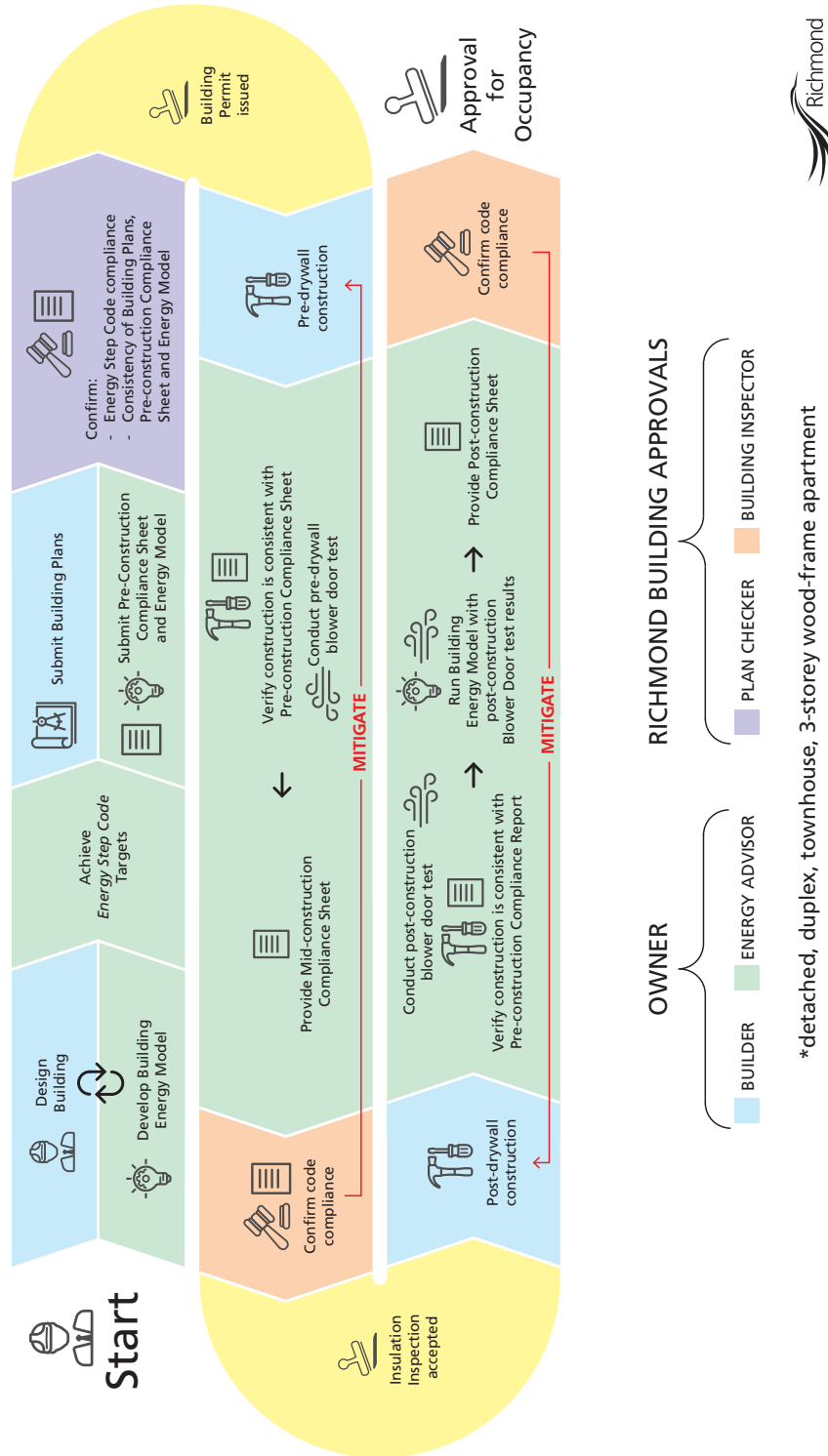

Appendix C: Sample Energy Modelling Results to Meet Step Code



Example Energy Modelling Results to Meet Step Code for Part 9 Buildings in Climate Zone 4

The following provides example results of energy modelling for a medium size Part 9 home in Climate Zone 4. Each example lists the building airtightness, the thermal performances of enclosure components, and the mechanical equipment used in the energy model to reach Step Code targets. These examples show what changes can be made compared to the prescriptive base code to meet the various steps of the Step Code.



This analysis is not intended to restrict the use of any enclosure assembly or mechanical system. The Step Code allows for many combinations of assemblies and systems that meets the energy performance requirements based on the energy modelling.

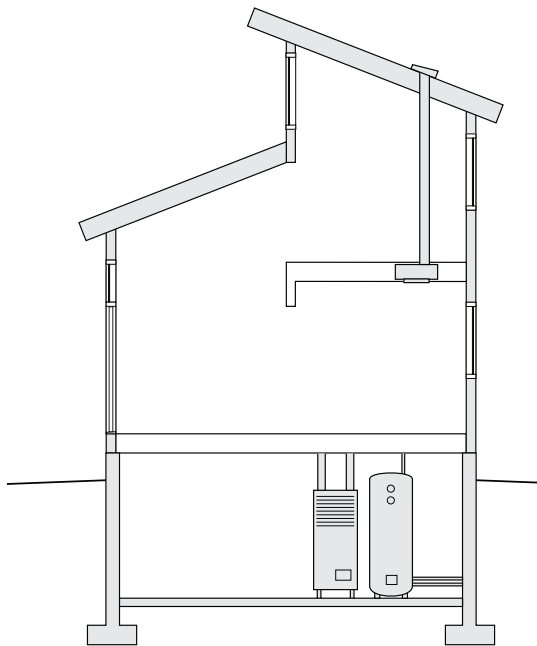

Example of Prescriptive Compliance for CZ 4

Without HRV	Airtightness (ACH50)	
	Above-Grade Wall	R-16 Effective
	Below-Grade Wall	R-11.3 Effective
	Unheated floors below frost line	
	Roof (attics)	R-40 Effective
	Fenestration and doors (Max U-value)	U-1.8
Mechanical	Domestic Hot Water	NG Tank, 0.67 EF / Electric Tank, 0.94 EF
	Drain Water Heat Recovery	
	Space Heating	NG Furnace, 92% AFUE / Electric Baseboards, 100% Efficiency
	Ventilation Heat Recovery	

Abbreviations Used in the Tables

ACH50 Air changes per hour at 50 Pascal pressure difference

SHGC Solar heat gain coefficient
NG Natural gas
EF Energy factor

AFUE Annual fuel utilization efficiency
COP Coefficient of performance
ASHP Air source heat pump

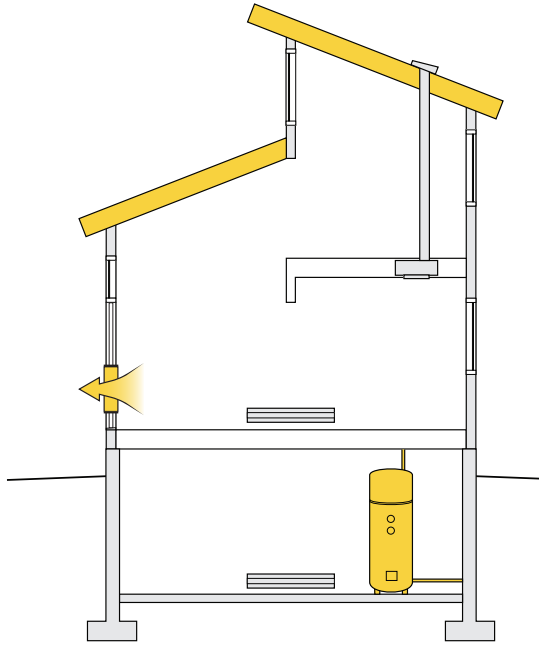

Example Step 1 Compliance for CZ 4

Enclosure	Airtightness (ACH50)	3.5	
	Above-Grade Wall	R-16 Effective	
	Below-Grade Wall	R-11.3 Effective	
	Unheated Floors Below Frost Line		
	Roof	R-50 Effective	▲
	Fenestration and doors	Double-glazed U-1.8 (SHGC 0.33)	
Mechanical	Domestic Hot Water	Heat Pump Tank, COP 2.3	▲
	Drain Water Heat Recovery		
	Space Heating	Electric Baseboards, 100% Efficiency	
	Ventilation Heat Recovery		

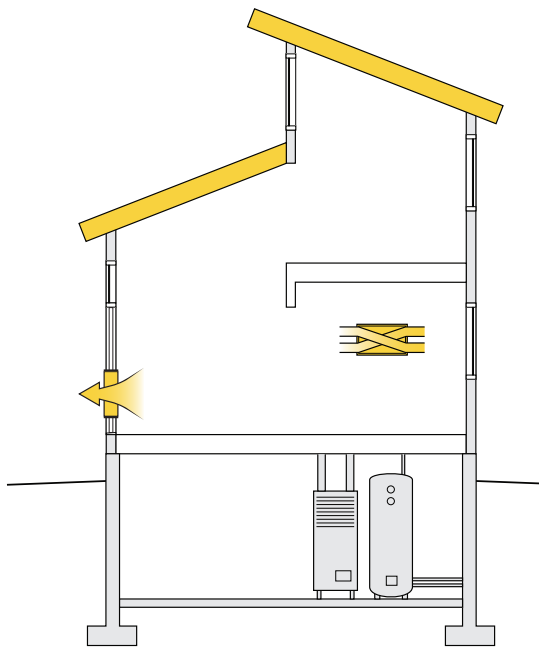

Example Step 1 Compliance for CZ 4

Enclosure	Airtightness (ACH50)	3.5	
	Above-Grade Wall	R-16 Effective	
	Below-Grade Wall	R-11.3 Effective	
	Unheated Floors Below Frost Line		
	Roof	R-50 Effective	▲
	Fenestration and doors	Double-glazed U-1.8 (SHGC 0.33)	
Mechanical	Domestic Hot Water	NG Tank, 0.67 EF	
	Drain Water Heat Recovery		
	Space Heating	NG Furnace, 92% AFUE	
	Ventilation Heat Recovery	60% Efficiency	▲

- No change in performance compared to current code
- ▲ Increase in performance compared to current code
- ▼ Decrease in performance compared to current code

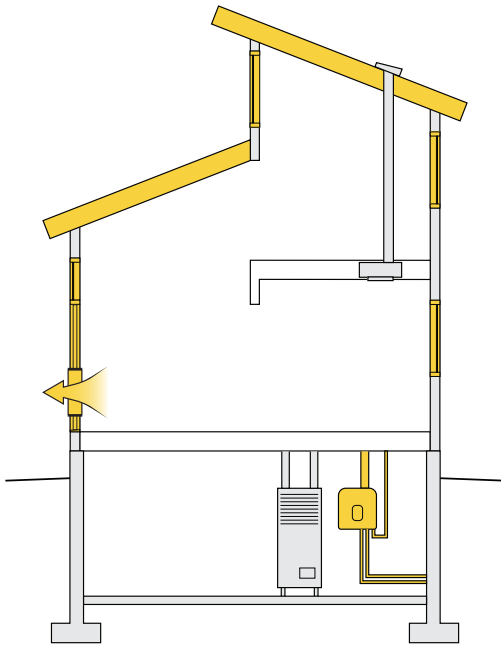

Example Step 2 Compliance for CZ 4

Enclosure	Airtightness (ACH50)	2.5	▲
	Above-Grade Wall	R-16 Effective	
	Below-Grade Wall	R-11.3 Effective	
	Unheated Floors Below Frost Line		
	Roof	R-50 Effective	▲
	Fenestration and doors	Double-glazed	
		U-1.6 (SHGC 0.33)	▲
Mechanical	Domestic Hot Water	Condensing NG Tankless, 0.94 EF	▲
	Drain Water Heat Recovery		
	Space Heating	NG Furnace, 92% AFUE	
	Ventilation Heat Recovery		

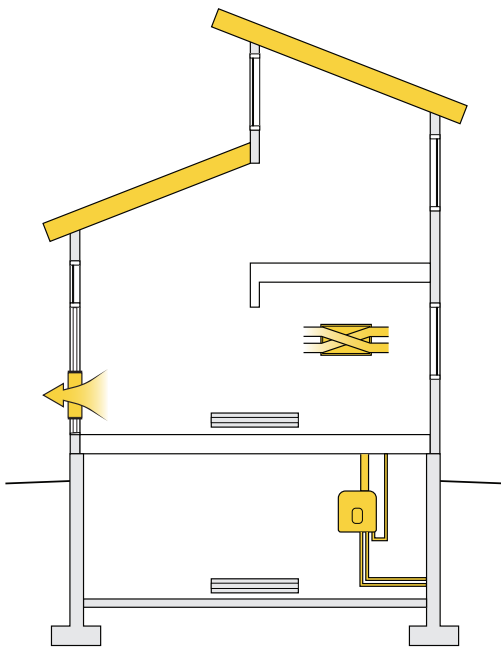

Example Step 2 Compliance for CZ 4

Enclosure	Airtightness (ACH50)	2.5	▲
	Above-Grade Wall	R-16 Effective	
	Below-Grade Wall	R-11.3 Effective	
	Unheated Floors Below Frost Line		
	Roof	R-50 Effective	▲
	Fenestration and doors	Double-glazed	
		U-1.8 (SHGC 0.33)	
Mechanical	Domestic Hot Water	Condensing NG Tankless, 0.94 EF	▲
	Drain Water Heat Recovery		
	Space Heating	Electric Baseboards, 100% Efficiency	
	Ventilation Heat Recovery	70% Efficiency	▲

- No change in performance compared to current code
- ▲ Increase in performance compared to current code
- ▼ Decrease in performance compared to current code

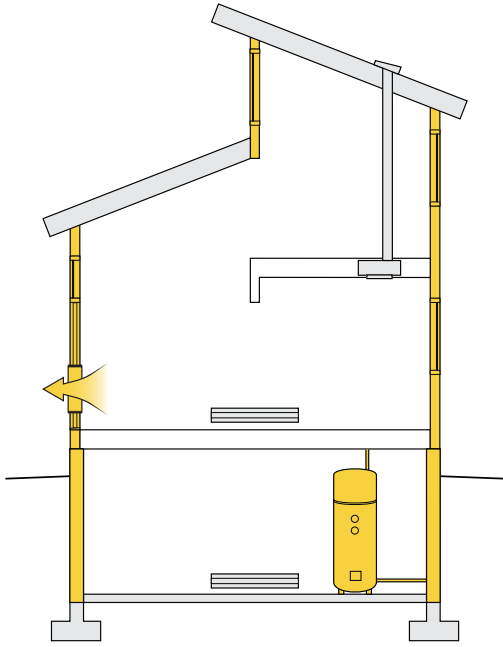

Example Step 3 Compliance for CZ 4

Enclosure	Airtightness (ACH50)	2.5	▲
	Above-Grade Wall	R-22 Effective	▲
	Below-Grade Wall	R-19.6 Effective	▲
	Unheated Floors Below Frost Line		
	Roof	R-40 Effective	
	Fenestration and doors	Double-glazed U-1.6 (SHGC 0.33)	▲
Mechanical	Domestic Hot Water	Heat Pump Tank, COP 2.3	▲
	Drain Water Heat Recovery		
	Space Heating	Electric Baseboards, 100% Efficiency	
	Ventilation Heat Recovery		

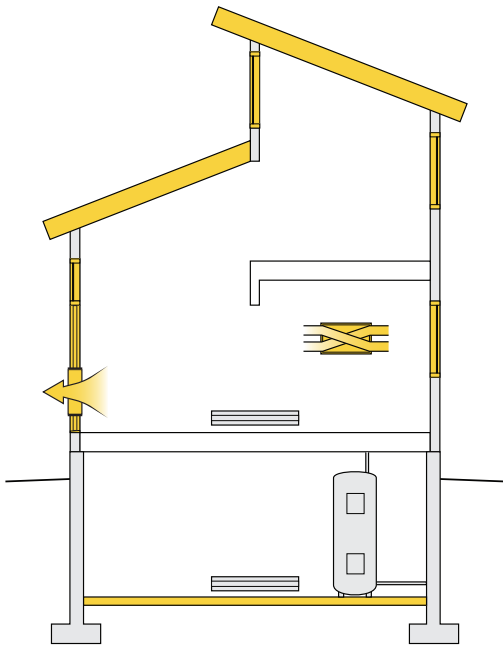

Example Step 3 Compliance for CZ 4

Enclosure	Airtightness (ACH50)	2.5	▲
	Above-Grade Wall	R-16 Effective	
	Below-Grade Wall	R-11.3 Effective	
	Unheated Floors Below Frost Line	R-11.1 Effective	▲
	Roof	R-50 Effective	▲
	Fenestration and doors	Double-glazed U-1.6 (SHGC 0.33)	▲
Mechanical	Domestic Hot Water	Electric Tank, 0.94 EF	
	Drain Water Heat Recovery		
	Space Heating	Electric Baseboards, 100% Efficiency	
	Ventilation Heat Recovery	60% Efficiency	▲

- No change in performance compared to current code
- ▲ Increase in performance compared to current code
- ▼ Decrease in performance compared to current code



Example Energy Modelling Results to Meet Step Code for Part 9 Buildings in Climate Zone 5

The following provides example results of energy modelling for a medium size Part 9 home in Climate Zone 5. Each example lists the building airtightness, the thermal performances of enclosure components, and the mechanical equipment used in the energy model to reach Step Code targets. These examples show what changes can be made compared to the prescriptive base code to meet the various steps of the Step Code.



This analysis is not intended to restrict the use of any enclosure assembly or mechanical system. The Step Code allows for many combinations of assemblies and systems that meets the energy performance requirements based on the energy modelling.

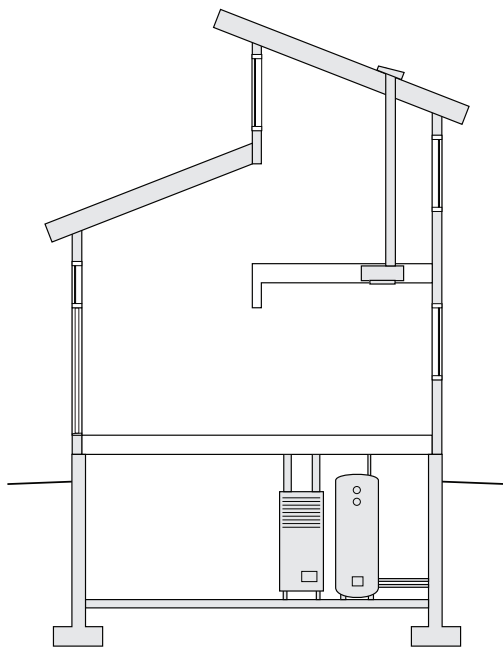

Example of Prescriptive Compliance for CZ 5

Without HRV	Airtightness (ACH50)	
	Above-Grade Wall	R-18 Effective
	Below-Grade Wall	R-17 Effective
	Unheated floors below frost line	
	Roof (attics)	R-50 Effective
	Fenestration and doors (Max U-value)	U-1.8
Mechanical	Domestic Hot Water	NG Tank, 0.67 EF / Electric Tank, 0.94 EF
	Drain Water Heat Recovery	
	Space Heating	NG Furnace, 92% AFUE / Electric Baseboards, 100% Efficiency
	Ventilation Heat Recovery	

Abbreviations Used in the Tables

ACH50 Air changes per hour at 50 Pascal pressure difference

SHGC Solar heat gain coefficient
NG Natural gas
EF Energy factor

AFUE Annual fuel utilization efficiency
COP Coefficient of performance
ASHP Air source heat pump

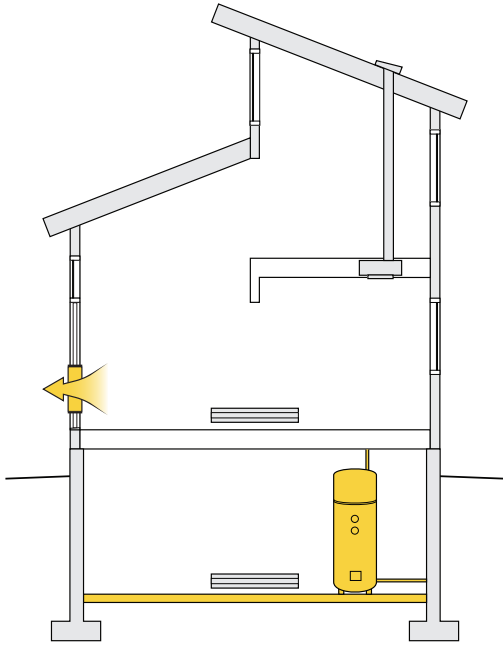

Example Step 1 Compliance for CZ 5

And	Airtightness (ACH50)	3.5	▲
	Above-Grade Wall	R-16 Effective	▼
	Below-Grade Wall	R-11.3 Effective	▼
	Unheated Floors Below Frost Line	R-15 Effective	▲
	Roof	R-40 Effective	▼
	Fenestration and doors	Double-glazed U-1.8 (SHGC 0.33)	
Mechanical	Domestic Hot Water	Heat Pump Tank, COP 2.3	▲
	Drain Water Heat Recovery		
	Space Heating	Electric Baseboards, 100% Efficiency	
	Ventilation Heat Recovery		

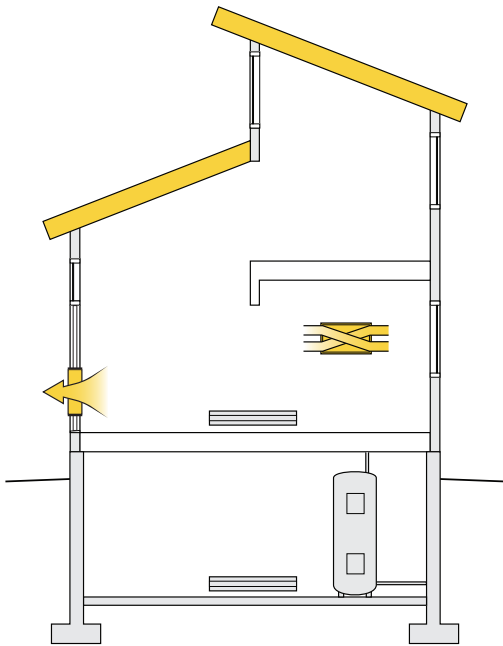

Example Step 1 Compliance for CZ 5

Enclosure	Airtightness (ACH50)	3.5	▲
	Above-Grade Wall	R-16 Effective	▼
	Below-Grade Wall	R-11.3 Effective	▼
	Unheated Floors Below Frost Line		
	Roof	R-100 Effective	▲
	Fenestration and doors	Double-glazed U-1.8 (SHGC 0.33)	
Mechanical	Domestic Hot Water	Electric Tank, 0.94 EF	
	Drain Water Heat Recovery		
	Space Heating	Electric Baseboards, 100% Efficiency	
	Ventilation Heat Recovery	75% Efficiency	▲

- No change in performance compared to current code
- ▲ Increase in performance compared to current code
- ▼ Decrease in performance compared to current code

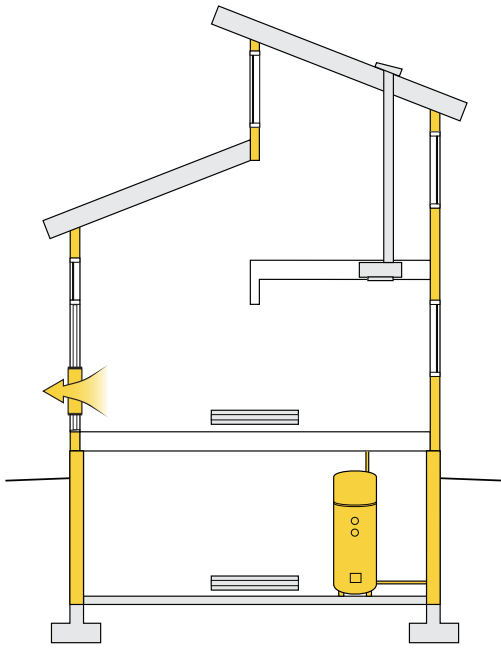

Example Step 2 Compliance for CZ 5

Enclosure	Airtightness (ACH50)	2.5	▲
	Above-Grade Wall	R-22 Effective	▲
	Below-Grade Wall	R-19.6 Effective	▲
	Unheated Floors Below Frost Line		
	Roof	R-40 Effective	▼
	Fenestration and doors	Double-glazed U-1.8 (SHGC 0.33)	
Mechanical	Domestic Hot Water	Heat Pump Tank, COP 2.3	▲
	Drain Water Heat Recovery		
	Space Heating	Electric Baseboards, 100% Efficiency	
	Ventilation Heat Recovery		

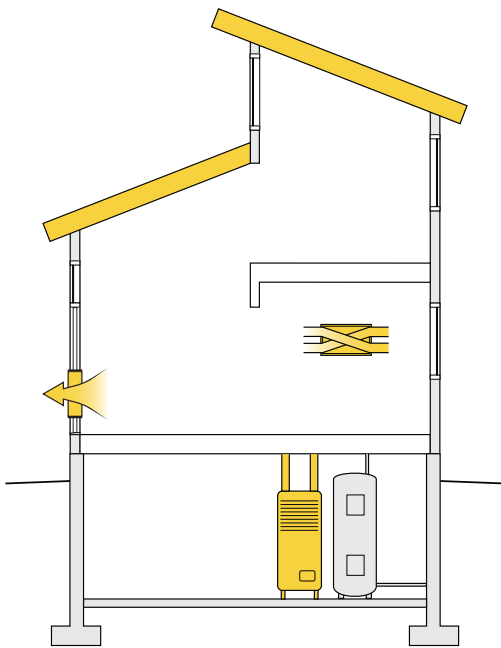

Example Step 2 Compliance for CZ 5

Enclosure	Airtightness (ACH50)	2.5	▲
	Above-Grade Wall	R-16 Effective	▼
	Below-Grade Wall	R-11.3 Effective	▼
	Unheated Floors Below Frost Line		
	Roof	R-50 Effective	
	Fenestration and doors	Double-glazed U-1.8 (SHGC 0.33)	
Mechanical	Domestic Hot Water	Electric Tank, 0.94 EF	
	Drain Water Heat Recovery		
	Space Heating	ECM NG Furnace, 95% AFUE	▲
	Ventilation Heat Recovery	75% Efficiency	▲

- No change in performance compared to current code
- ▲ Increase in performance compared to current code
- ▼ Decrease in performance compared to current code

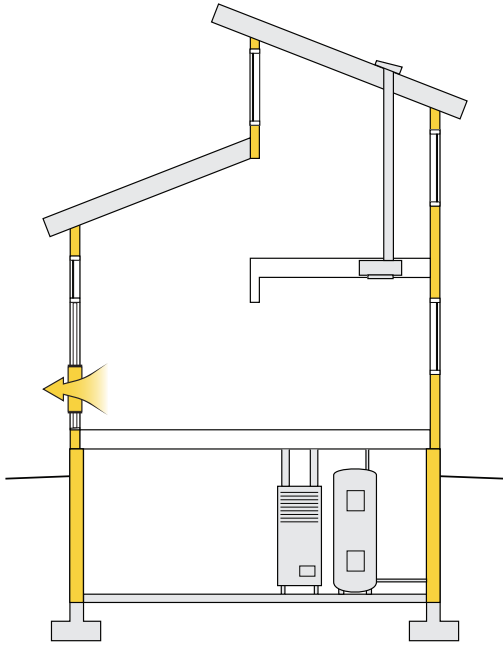

Example Step 3 Compliance for CZ 5

Enclosure	Airtightness (ACH50)	2.5	▲
	Above-Grade Wall	R-24 Effective	▲
	Below-Grade Wall	R-25 Effective	▲
	Unheated Floors Below Frost Line		
	Roof	R-40 Effective	▼
	Fenestration and doors	Double-glazed U-1.8 (SHGC 0.33)	
Mechanical	Domestic Hot Water	Electric Tank, 0.94 EF	
	Drain Water Heat Recovery		
	Space Heating	NG Furnace, 92% AFUE	
	Ventilation Heat Recovery		

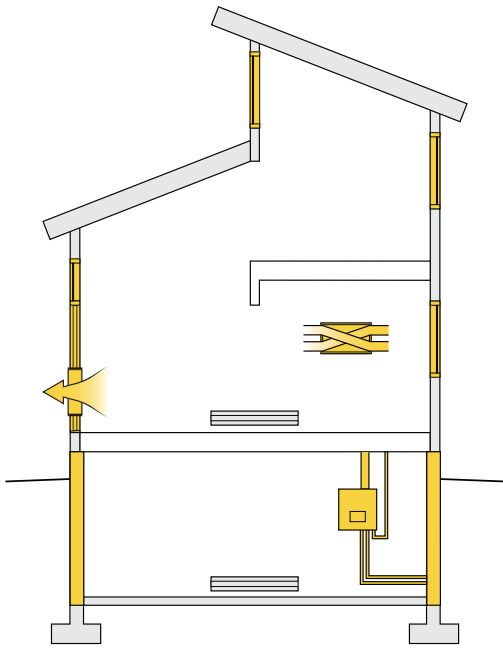

Example Step 3 Compliance for CZ 5

Enclosure	Airtightness (ACH50)	2.5	▲
	Above-Grade Wall	R-16 Effective	▼
	Below-Grade Wall	R-19.6 Effective	▲
	Unheated Floors Below Frost Line		
	Roof	R-40 Effective	▼
	Fenestration and doors	Double-glazed U-1.6 (SHGC 0.33)	▲
Mechanical	Domestic Hot Water	NG Tank, 0.67 EF	
	Drain Water Heat Recovery		
	Space Heating	Electric Baseboards, 100% Efficiency	
	Ventilation Heat Recovery	70% Efficiency	▲

- No change in performance compared to current code
- ▲ Increase in performance compared to current code
- ▼ Decrease in performance compared to current code



Example Energy Modelling Results to Meet Step Code for Part 9 Buildings in Climate Zone 6

The following provides example results of energy modelling for a medium size Part 9 home in Climate Zone 6. Each example lists the building airtightness, the thermal performances of enclosure components, and the mechanical equipment used in the energy model to reach Step Code targets. These examples show what changes can be made compared to the prescriptive base code to meet the various steps of the Step Code.

This analysis is not intended to restrict the use of any enclosure assembly or mechanical system. The Step Code allows for many combinations of assemblies and systems that meets the energy performance requirements based on the energy modelling.

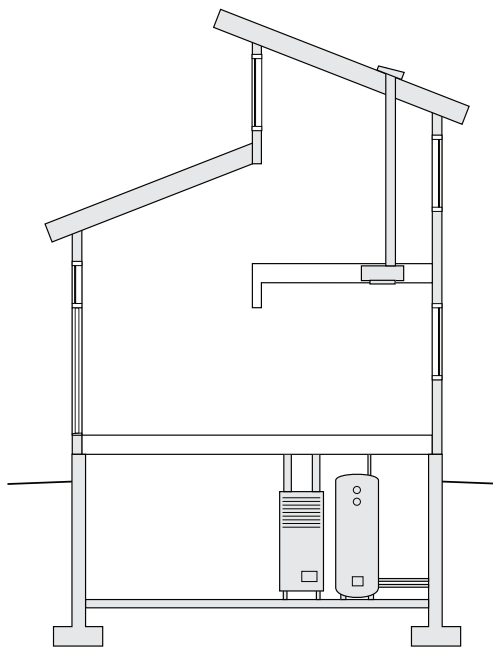

Example of Prescriptive Compliance for CZ 6

Without HRV	Airtightness (ACH50)	
	Above-Grade Wall	R-18 Effective
	Below-Grade Wall	R-17 Effective
	Unheated floors below frost line	
	Roof (attics)	R-50 Effective
	Fenestration and doors (Max U-value)	U-1.6
Mechanical	Domestic Hot Water	NG Tank, 0.67 EF / Electric Tank, 0.94 EF
	Drain Water Heat Recovery	
	Space Heating	NG Furnace, 92% AFUE / Electric Baseboards, 100% Efficiency
	Ventilation Heat Recovery	

Abbreviations Used in the Tables

ACH50 Air changes per hour at 50 Pascal pressure difference

SHGC Solar heat gain coefficient

NG Natural gas

EF Energy factor

AFUE Annual fuel utilization efficiency

COP Coefficient of performance

ASHP Air source heat pump

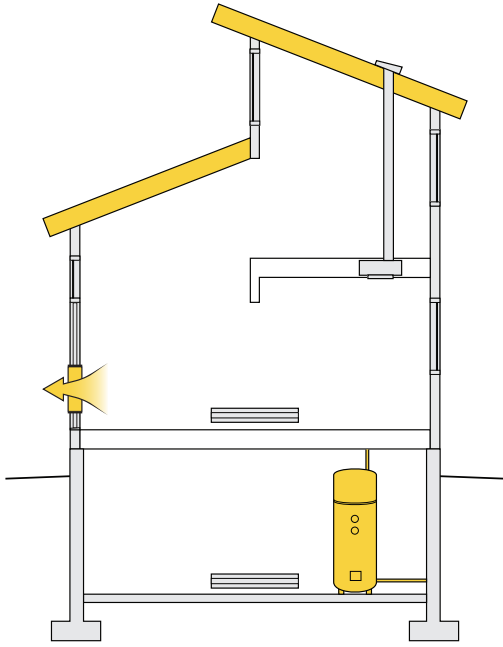

Example Step 1 Compliance for CZ 6

Enclosure	Airtightness (ACH50)	3.5	▲
	Above-Grade Wall	R-16 Effective	▼
	Below-Grade Wall	R-11.3 Effective	▼
	Unheated Floors Below Frost Line		
	Roof	R-70 Effective	▲
	Fenestration and doors	Double-glazed U-1.6 (SHGC 0.33)	
Mechanical	Domestic Hot Water	Heat Pump Tank, COP 2.3	▲
	Drain Water Heat Recovery		
	Space Heating	Electric Baseboards, 100% Efficiency	
	Ventilation Heat Recovery		

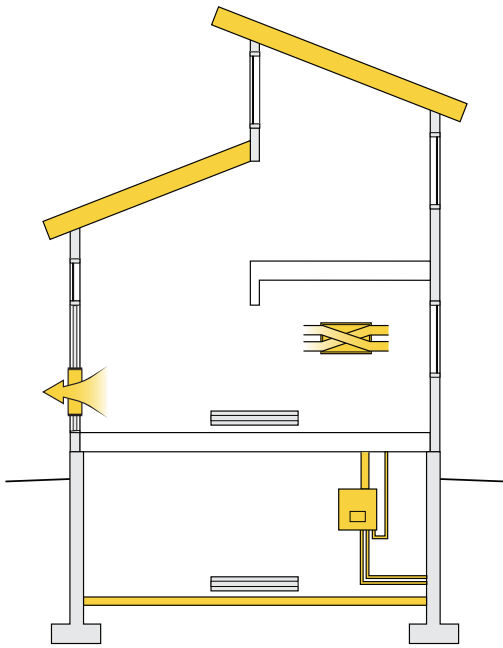

Example Step 1 Compliance for CZ 6

Enclosure	Airtightness (ACH50)	3.5	▲
	Above-Grade Wall	R-16 Effective	▼
	Below-Grade Wall	R-11.3 Effective	▼
	Unheated Floors Below Frost Line	R-11 Effective	▲
	Roof	R-100 Effective	▲
	Fenestration and doors	Double-glazed U-1.8 (SHGC 0.33)	▼
Mechanical	Domestic Hot Water	NG Tankless, 0.8 EF	▲
	Drain Water Heat Recovery		
	Space Heating	Electric Baseboards, 100% Efficiency	
	Ventilation Heat Recovery	75% Efficiency	▲

- No change in performance compared to current code
- ▲ Increase in performance compared to current code
- ▼ Decrease in performance compared to current code

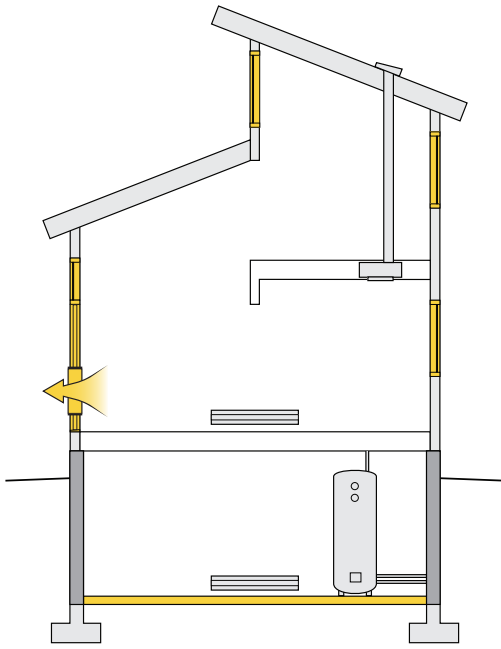

Example Step 2 Compliance for CZ 6

Enclosure	Airtightness (ACH50)	2.5	▲
	Above-Grade Wall	R-16 Effective	▼
	Below-Grade Wall	R-16.9 Effective	▼
	Unheated Floors Below Frost Line	R-11.1 Effective	▲
	Roof	R-40 Effective	▼
	Fenestration and doors	Double-glazed U-1.6 (SHGC 0.33)	
Mechanical	Domestic Hot Water	NG Tank, 0.67 EF	
	Drain Water Heat Recovery		
	Space Heating	Electric Baseboards, 100% Efficiency	
	Ventilation Heat Recovery		

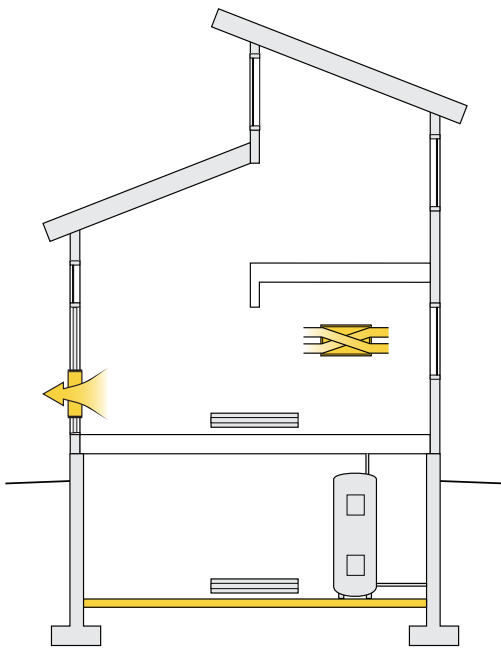

Example Step 2 Compliance for CZ 6

Enclosure	Airtightness (ACH50)	2.5	▲
	Above-Grade Wall	R-16 Effective	▼
	Below-Grade Wall	R-16.9 Effective	▼
	Unheated Floors Below Frost Line	R-11.1 Effective	▲
	Roof	R-40 Effective	▼
	Fenestration and doors	Double-glazed U-1.8 (SHGC 0.33)	▼
Mechanical	Domestic Hot Water	Electric Tank, 0.94 EF	
	Drain Water Heat Recovery		
	Space Heating	Electric Baseboards, 100% Efficiency	
	Ventilation Heat Recovery	84% Efficiency	▲

- No change in performance compared to current code
- ▲ Increase in performance compared to current code
- ▼ Decrease in performance compared to current code

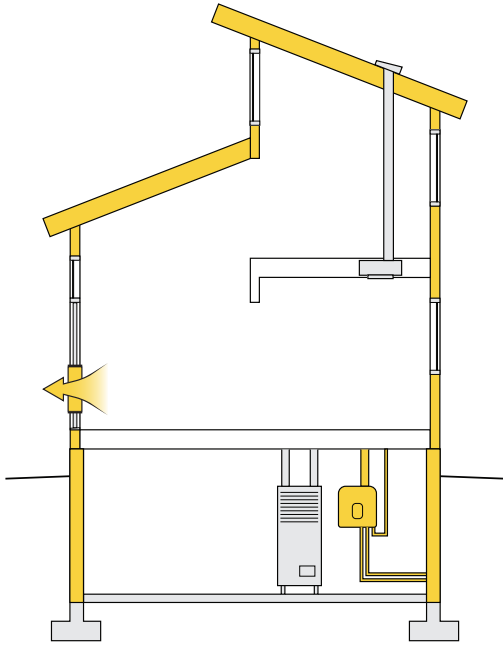

Example Step 3 Compliance for CZ 6

Enclosure	Airtightness (ACH50)	2.5	▲
	Above-Grade Wall	R-22 Effective	▲
	Below-Grade Wall	R-25 Effective	▲
	Unheated Floors Below Frost Line		
	Roof	R-100 Effective	▲
	Fenestration and doors	Double-glazed U-1.6 (SHGC 0.33)	
Mechanical	Domestic Hot Water	Condensing NG Tankless, 0.94 EF	▲
	Drain Water Heat Recovery		
	Space Heating	NG Furnace, 92% AFUE	
	Ventilation Heat Recovery		

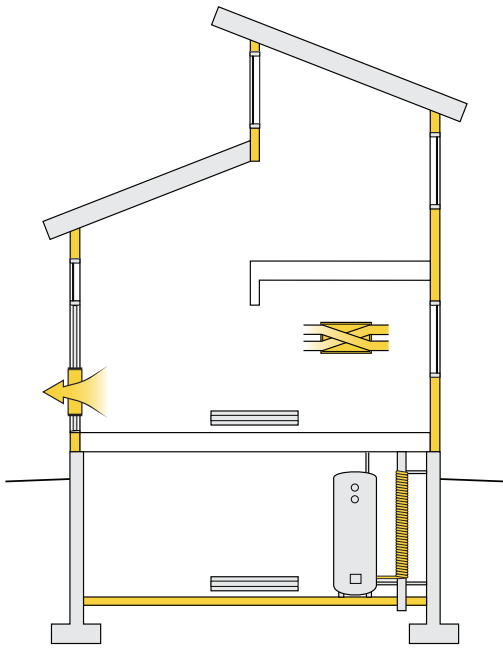

Example Step 3 Compliance for CZ 6

Enclosure	Airtightness (ACH50)	2.5	▲
	Above-Grade Wall	R-22 Effective	▲
	Below-Grade Wall	R-16.9 Effective	▼
	Unheated Floors Below Frost Line	R-11.1 Effective	▲
	Roof	R-40 Effective	▼
	Fenestration and doors	Double-glazed U-1.6 (SHGC 0.33)	
Mechanical	Domestic Hot Water	NG Tank, 0.67 EF	
	Drain Water Heat Recovery	42% Efficient	▲
	Space Heating	Electric Baseboards, 100% Efficiency	
	Ventilation Heat Recovery	60% Efficiency	▲

- No change in performance compared to current code
- ▲ Increase in performance compared to current code
- ▼ Decrease in performance compared to current code



Example Energy Modelling Results to Meet Step Code for Part 9 Buildings in Climate Zone 7A

The following provides example results of energy modelling for a medium size Part 9 home in Climate Zone 7A. Each example lists the building airtightness, the thermal performances of enclosure components, and the mechanical equipment used in the energy model to reach Step Code targets. These examples show what changes can be made compared to the prescriptive base code to meet the various steps of the Step Code.



This analysis is not intended to restrict the use of any enclosure assembly or mechanical system. The Step Code allows for many combinations of assemblies and systems that meets the energy performance requirements based on the energy modelling.

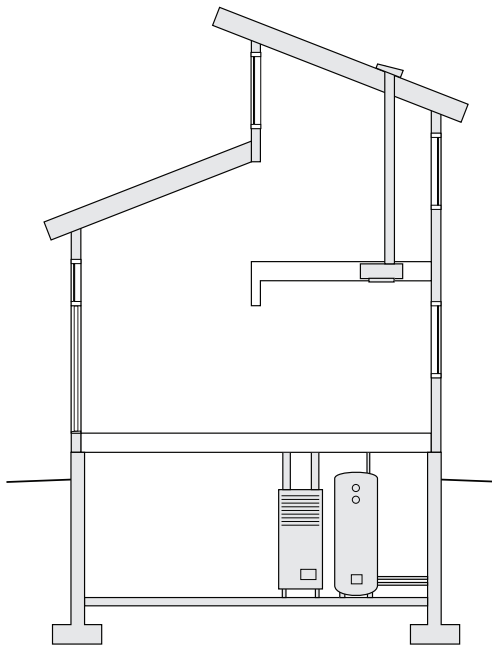

Example of Prescriptive Compliance for CZ 7A

Without HRV	Airtightness (ACH50)	
	Above-Grade Wall	R-18 Effective
	Below-Grade Wall	R-20 Effective
	Unheated floors below frost line	
	Roof (attics)	R-60 Effective
	Fenestration and doors (Max U-value)	U-1.6
Mechanical	Domestic Hot Water	NG Tank, 0.67 EF / Electric Tank, 0.94 EF
	Drain Water Heat Recovery	
	Space Heating	NG Furnace, 92% AFUE / Electric Baseboards, 100% Efficiency
	Ventilation Heat Recovery	

Abbreviations Used in the Tables

ACH50 Air changes per hour at 50 Pascal pressure difference

SHGC Solar heat gain coefficient
NG Natural gas
EF Energy factor

AFUE Annual fuel utilization efficiency
COP Coefficient of performance
ASHP Air source heat pump

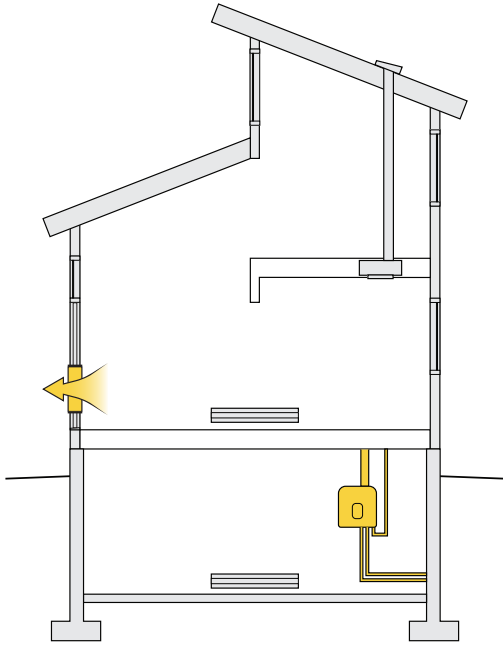

Example Step 1 Compliance for CZ 7A

Enclosure	Airtightness (ACH50)	3.5	▲
	Above-Grade Wall	R-18 Effective	■
	Below-Grade Wall	R-16.9 Effective	▼
	Unheated Floors Below Frost Line		■
	Roof	R-50 Effective	▼
	Fenestration and doors	Double-glazed U-1.6 (SHGC 0.33)	■
Mechanical	Domestic Hot Water	Condensing NG Tankless, 0.94 EF	▲
	Drain Water Heat Recovery		■
	Space Heating	Electric Baseboards, 100% Efficiency	■
	Ventilation Heat Recovery		■

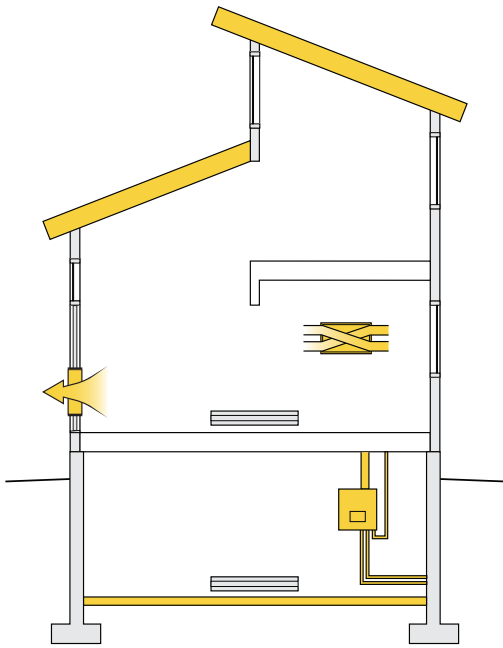

Example Step 1 Compliance for CZ 7A

Enclosure	Airtightness (ACH50)	3.5	▲
	Above-Grade Wall	R-24 Effective	▲
	Below-Grade Wall	R-11.3 Effective	▼
	Unheated Floors Below Frost Line		■
	Roof	R-40 Effective	▼
	Fenestration and doors	Double-glazed U-1.8 (SHGC 0.33)	▼
Mechanical	Domestic Hot Water	NG Tankless, 0.8 EF	▲
	Drain Water Heat Recovery		■
	Space Heating	Electric Baseboards, 100% Efficiency	■
	Ventilation Heat Recovery	60% Efficiency	▲

- No change in performance compared to current code
- ▲ Increase in performance compared to current code
- ▼ Decrease in performance compared to current code

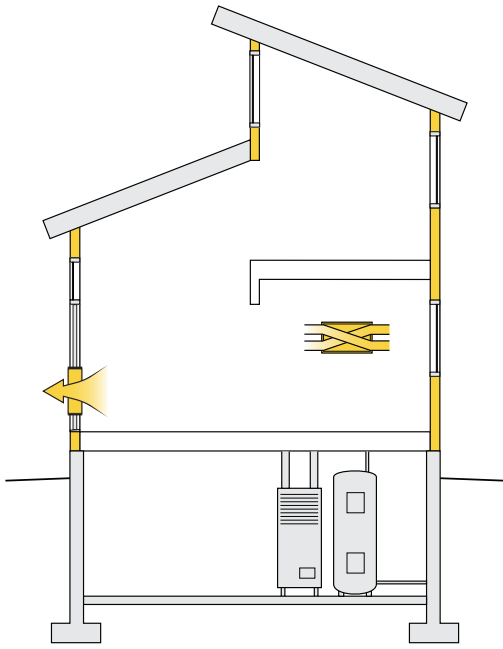

Example Step 2 Compliance for CZ 7A

Enclosure	Airtightness (ACH50)	2.5	▲
	Above-Grade Wall	R-24 Effective	▲
	Below-Grade Wall	R-16.9 Effective	▼
	Unheated Floors Below Frost Line		
	Roof	R-40 Effective	▼
	Fenestration and doors	Double-glazed U-1.8 (SHGC 0.33)	▼
Mechanical	Domestic Hot Water	Electric Tank, 0.94 EF	
	Drain Water Heat Recovery		
	Space Heating	NG Furnace, 92% AFUE	
	Ventilation Heat Recovery	60% Efficiency	▲

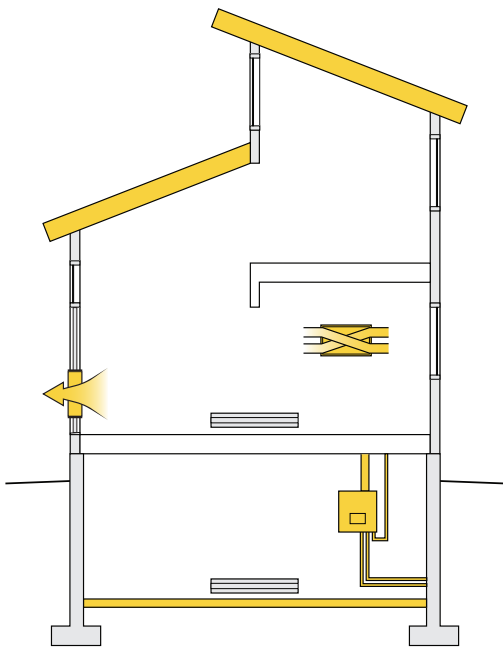

Example Step 2 Compliance for CZ 7A

Enclosure	Airtightness (ACH50)	2.5	▲
	Above-Grade Wall	R-18 Effective	
	Below-Grade Wall	R-11.3 Effective	▼
	Unheated Floors Below Frost Line	R-15 Effective	▲
	Roof	R-70 Effective	▲
	Fenestration and doors	Double-glazed U-1.8 (SHGC 0.33)	▼
Mechanical	Domestic Hot Water	NG Tankless, 0.8 EF	▲
	Drain Water Heat Recovery		
	Space Heating	Electric Baseboards, 100% Efficiency	
	Ventilation Heat Recovery	75% Efficiency	▲

- No change in performance compared to current code
- ▲ Increase in performance compared to current code
- ▼ Decrease in performance compared to current code

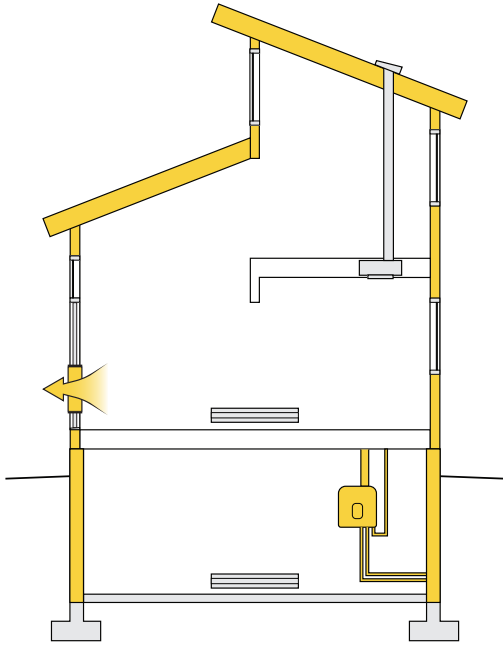

Example Step 3 Compliance for CZ 7A

Enclosure	Airtightness (ACH50)	2.5	▲
	Above-Grade Wall	R-30 Effective	▲
	Below-Grade Wall	R-25 Effective	▲
	Unheated Floors Below Frost Line		
	Roof	R-80 Effective	▲
	Fenestration and doors	Double-glazed U-1.6 (SHGC 0.33)	
Mechanical	Domestic Hot Water	Condensing NG Tankless, 0.94 EF	▲
	Drain Water Heat Recovery		
	Space Heating	Electric Baseboards, 100% Efficiency	
	Ventilation Heat Recovery		

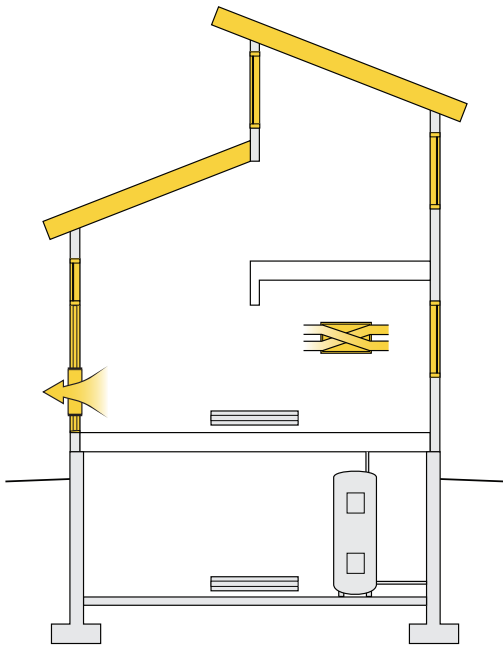

Example Step 3 Compliance for CZ 7A

Enclosure	Airtightness (ACH50)	2.5	▲
	Above-Grade Wall	R-18 Effective	
	Below-Grade Wall	R-11.3 Effective	▼
	Unheated Floors Below Frost Line		
	Roof	R-70 Effective	▲
	Fenestration and doors	Triple-glazed U-1.0 (SHGC 0.35)	▲
Mechanical	Domestic Hot Water	Electric Tank, 0.94 EF	
	Drain Water Heat Recovery		
	Space Heating	Electric Baseboards, 100% Efficiency	
	Ventilation Heat Recovery	60% Efficiency	▲

- No change in performance compared to current code
- ▲ Increase in performance compared to current code
- ▼ Decrease in performance compared to current code



Example Energy Modelling Results to Meet Step Code for Part 9 Buildings in Climate Zone 7B

The following provides example results of energy modelling for a medium size Part 9 home in Climate Zone 7B. Each example lists the building airtightness, the thermal performances of enclosure components, and the mechanical equipment used in the energy model to reach Step Code targets. These examples show what changes can be made compared to the prescriptive base code to meet the various steps of the Step Code.

This analysis is not intended to restrict the use of any enclosure assembly or mechanical system. The Step Code allows for many combinations of assemblies and systems that meets the energy performance requirements based on the energy modelling.

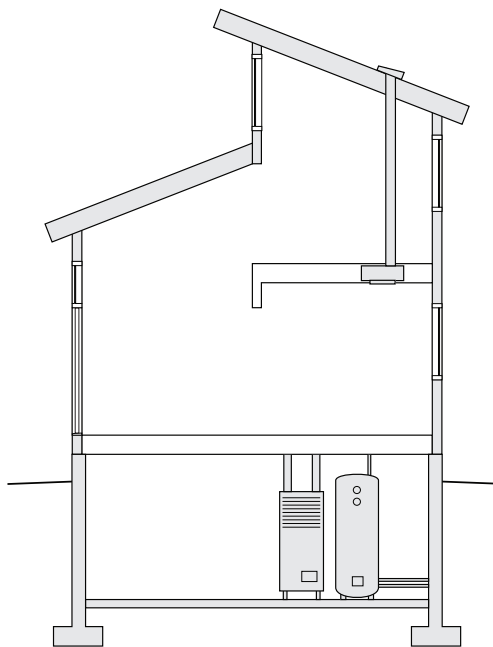

Example of Prescriptive Compliance for CZ 7B

Without HRV	Airtightness (ACH50)	
	Above-Grade Wall	R-22 Effective
	Below-Grade Wall	R-20 Effective
	Unheated floors below frost line	
	Roof (attics)	R-60 Effective
	Fenestration and doors (Max U-value)	U-1.4
Mechanical	Domestic Hot Water	NG Tank, 0.67 EF / Electric Tank, 0.94 EF
	Drain Water Heat Recovery	
	Space Heating	NG Furnace, 92% AFUE / Electric Baseboards, 100% Efficiency
	Ventilation Heat Recovery	

Abbreviations Used in the Tables

ACH50 Air changes per hour at 50 Pascal pressure difference

SHGC Solar heat gain coefficient
NG Natural gas
EF Energy factor

AFUE Annual fuel utilization efficiency
COP Coefficient of performance
ASHP Air source heat pump

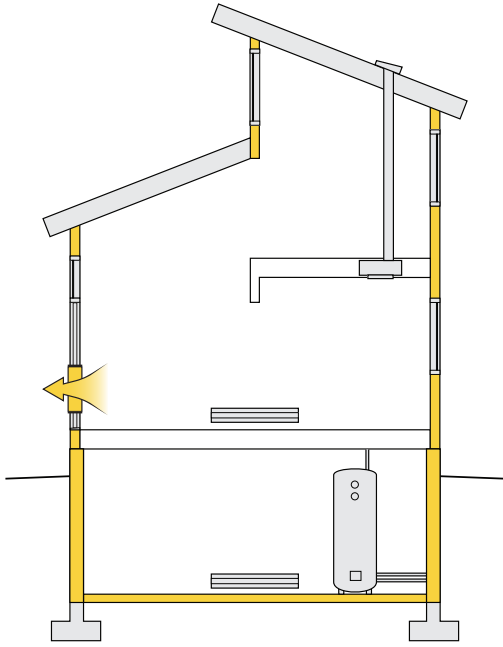

Example Step 1 Compliance for CZ 7B

Enclosure	Airtightness (ACH50)	3.5	▲
	Above-Grade Wall	R-24 Effective	▲
	Below-Grade Wall	R-25 Effective	▲
	Unheated Floors Below Frost Line	R-11.1 Effective	▲
	Roof	R-40 Effective	▼
	Fenestration and doors	Double-glazed	
		U-1.6 (SHGC 0.33)	▼
Mechanical	Domestic Hot Water	NG Tank, 0.67 EF	
	Drain Water Heat Recovery		
	Space Heating	Electric Baseboards, 100% Efficiency	
	Ventilation Heat Recovery		

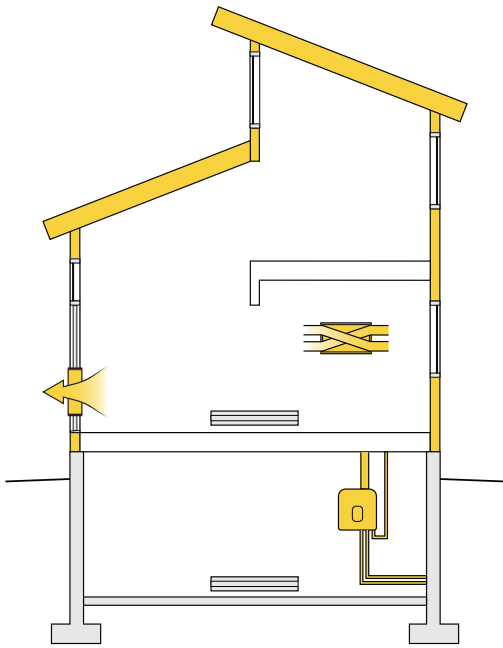

Example Step 1 Compliance for CZ 7B

Enclosure	Airtightness (ACH50)	3.5	▲
	Above-Grade Wall	R-24 Effective	▲
	Below-Grade Wall	R-19.6 Effective	▼
	Unheated Floors Below Frost Line		
	Roof	R-100 Effective	▲
	Fenestration and doors	Double-glazed	
		U-1.6 (SHGC 0.33)	▼
Mechanical	Domestic Hot Water	Condensing NG Tankless, 0.94 EF	▲
	Drain Water Heat Recovery		
	Space Heating	Electric Baseboards, 100% Efficiency	
	Ventilation Heat Recovery	70% Efficiency	▲

- No change in performance compared to current code
- ▲ Increase in performance compared to current code
- ▼ Decrease in performance compared to current code

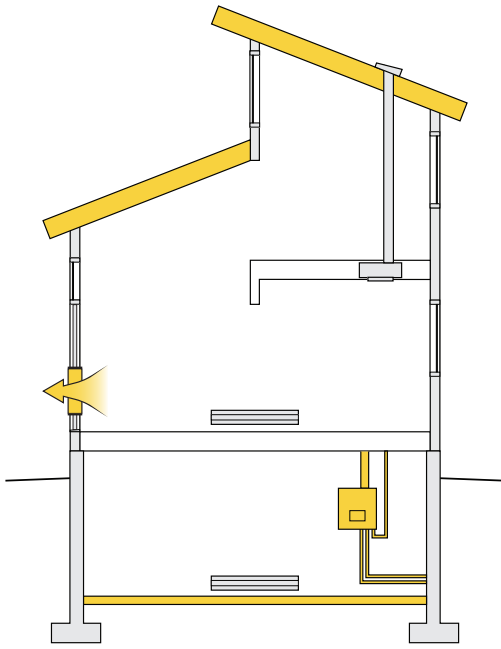

Example Step 2 Compliance for CZ 7B

Enclosure	Airtightness (ACH50)	2.5	▲
	Above-Grade Wall	R-22 Effective	■
	Below-Grade Wall	R-19.6 Effective	▼
	Unheated Floors Below Frost Line	R-20 Effective	▲
	Roof	R-100 Effective	▲
	Fenestration and doors	Double-glazed	■
		U-1.6 (SHGC 0.33)	▼
Mechanical	Domestic Hot Water	NG Tankless, 0.8 EF	▲
	Drain Water Heat Recovery		■
	Space Heating	Electric Baseboards, 100% Efficiency	■
	Ventilation Heat Recovery		■

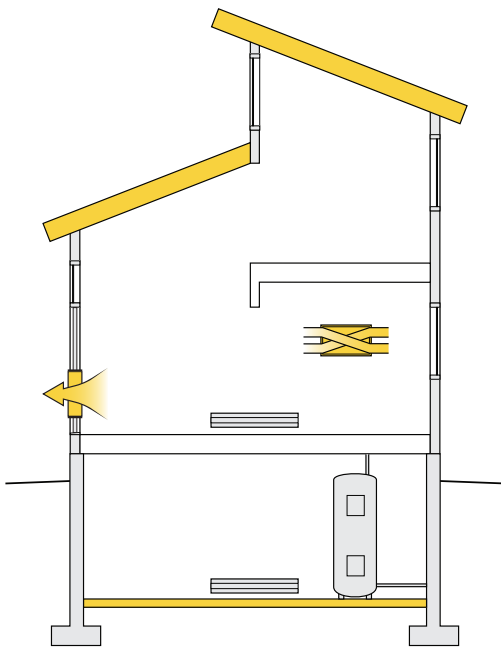

Example Step 2 Compliance for CZ 7B

Enclosure	Airtightness (ACH50)	2.5	▲
	Above-Grade Wall	R-16 Effective	▼
	Below-Grade Wall	R-11.3 Effective	▼
	Unheated Floors Below Frost Line	R-15 Effective	▲
	Roof	R-70 Effective	▲
	Fenestration and doors	Double-glazed	■
		U-1.6 (SHGC 0.33)	▼
Mechanical	Domestic Hot Water	Electric Tank, 0.94 EF	■
	Drain Water Heat Recovery		■
	Space Heating	Electric Baseboards, 100% Efficiency	■
	Ventilation Heat Recovery	75% Efficiency	▲

- No change in performance compared to current code
- ▲ Increase in performance compared to current code
- ▼ Decrease in performance compared to current code

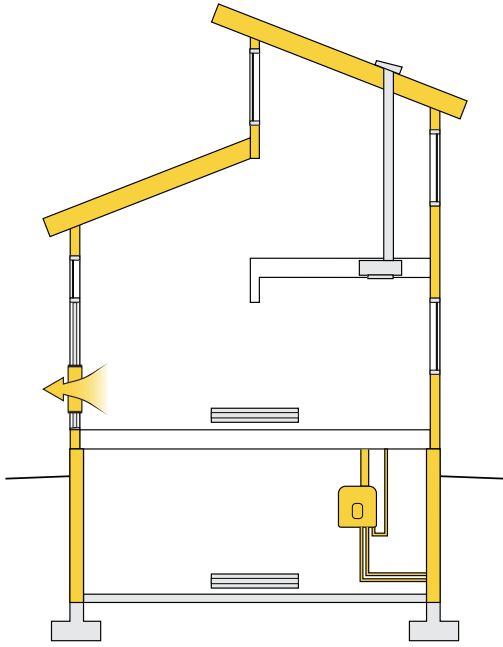

Example Step 3 Compliance for CZ 7B

Enclosure	Airtightness (ACH50)	2.5	▲
	Above-Grade Wall	R-30 Effective	▲
	Below-Grade Wall	R-25 Effective	▲
	Unheated Floors Below Frost Line		
	Roof	R-80 Effective	▲
	Fenestration and doors	Double-glazed U-1.6 (SHGC 0.33)	▼
Mechanical	Domestic Hot Water	Condensing NG Tankless, 0.94 EF	▲
	Drain Water Heat Recovery		
	Space Heating	Electric Baseboards, 100% Efficiency	
	Ventilation Heat Recovery		

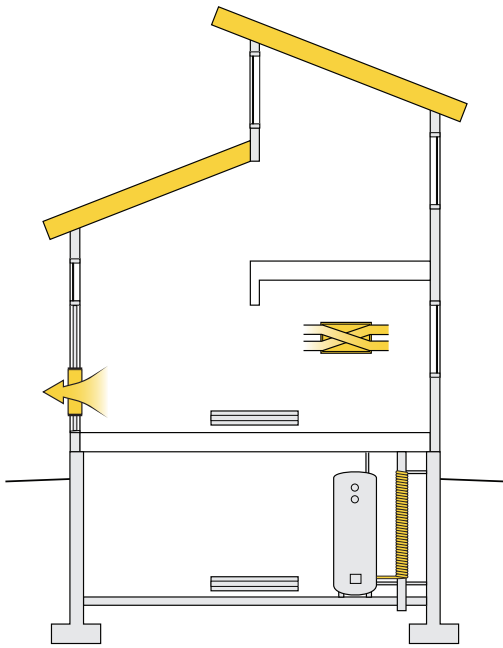

Example Step 3 Compliance for CZ 7B

Enclosure	Airtightness (ACH50)	2.5	▲
	Above-Grade Wall	R-22 Effective	
	Below-Grade Wall	R-16.9 Effective	▼
	Unheated Floors Below Frost Line		
	Roof	R-100 Effective	▲
	Fenestration and doors	Double-glazed U-1.4 (SHGC 0.33)	
Mechanical	Domestic Hot Water	NG Tank, 0.67 EF	
	Drain Water Heat Recovery	30% Efficient	▲
	Space Heating	Electric Baseboards, 100% Efficiency	
	Ventilation Heat Recovery	60% Efficiency	▲

- No change in performance compared to current code
- ▲ Increase in performance compared to current code
- ▼ Decrease in performance compared to current code



Example Energy Modelling Results to Meet Step Code for Part 9 Buildings in Climate Zone 8

The following provides example results of energy modelling for a medium size Part 9 home in Climate Zone 8. Each example lists the building airtightness, the thermal performances of enclosure components, and the mechanical equipment used in the energy model to reach Step Code targets. These examples show what changes can be made compared to the prescriptive base code to meet the various steps of the Step Code.

This analysis is not intended to restrict the use of any enclosure assembly or mechanical system. The Step Code allows for many combinations of assemblies and systems that meets the energy performance requirements based on the energy modelling.

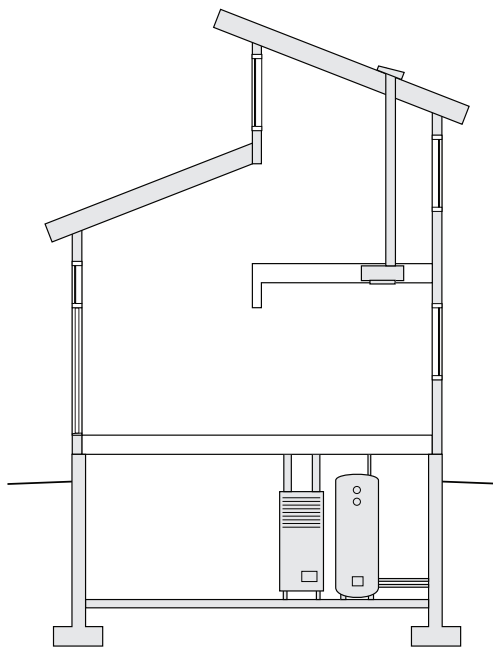

Example of Prescriptive Compliance for CZ 8

Without HRV	Airtightness (ACH50)	
	Above-Grade Wall	R-22 Effective
	Below-Grade Wall	R-23 Effective
	Unheated floors below frost line	
	Roof (attics)	R-60 Effective
	Fenestration and doors (Max U-value)	U-1.4
Mechanical	Domestic Hot Water	NG Tank, 0.67 EF / Electric Tank, 0.94 EF
	Drain Water Heat Recovery	
	Space Heating	NG Furnace, 92% AFUE / Electric Baseboards, 100% Efficiency
	Ventilation Heat Recovery	

Abbreviations Used in the Tables

ACH50 Air changes per hour at 50 Pascal pressure difference

SHGC Solar heat gain coefficient
NG Natural gas
EF Energy factor

AFUE Annual fuel utilization efficiency
COP Coefficient of performance
ASHP Air source heat pump

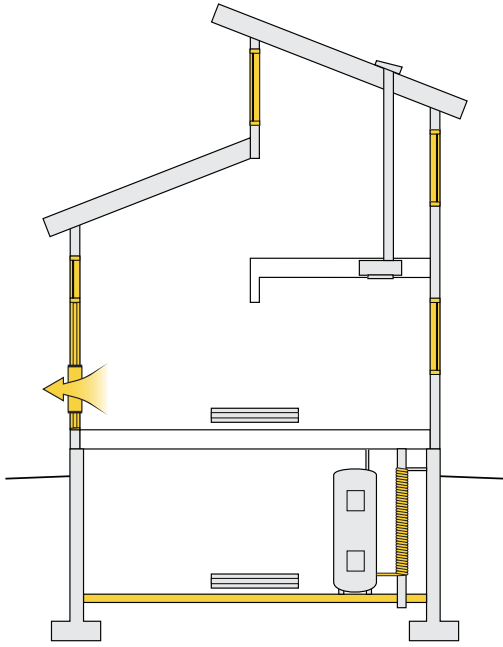

Example Step 1 Compliance for CZ 8

Enclosure	Airtightness (ACH50)	3.5	▲
	Above-Grade Wall	R-22 Effective	■
	Below-Grade Wall	R-19.6 Effective	▼
	Unheated Floors Below Frost Line	R-11.1 Effective	▲
	Roof	R-50 Effective	▼
	Fenestration and doors	Triple-glazed	▲
		U-0.8 (SHGC 0.5)	▲
Mechanical	Domestic Hot Water	Electric Tank, 0.94 EF	■
	Drain Water Heat Recovery	55% Efficiency	▲
	Space Heating	Electric Baseboards, 100% Efficiency	■
	Ventilation Heat Recovery		■

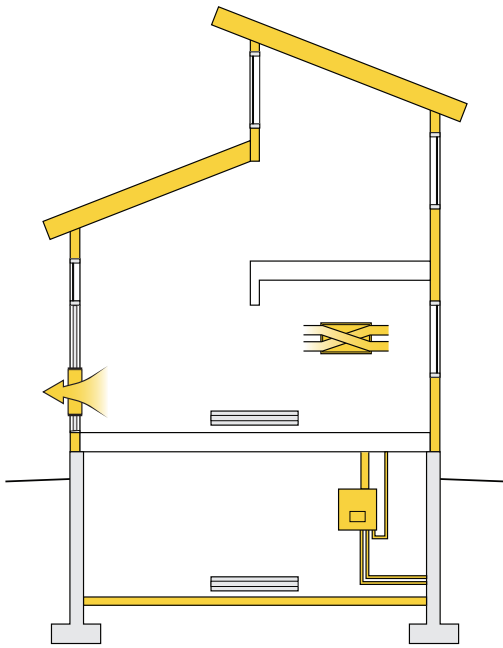

Example Step 1 Compliance for CZ 8

Enclosure	Airtightness (ACH50)	3.5	▲
	Above-Grade Wall	R-40 Effective	▲
	Below-Grade Wall	R-16.9 Effective	▼
	Unheated Floors Below Frost Line	R-11.1 Effective	▲
	Roof	R-100 Effective	▲
	Fenestration and doors	Double-glazed	■
		U-1.8 (SHGC 0.33)	▼
Mechanical	Domestic Hot Water	NG Tankless, 0.8 EF	▲
	Drain Water Heat Recovery		■
	Space Heating	Electric Baseboards, 100% Efficiency	■
	Ventilation Heat Recovery	84% Efficiency	▲

- No change in performance compared to current code
- ▲ Increase in performance compared to current code
- ▼ Decrease in performance compared to current code

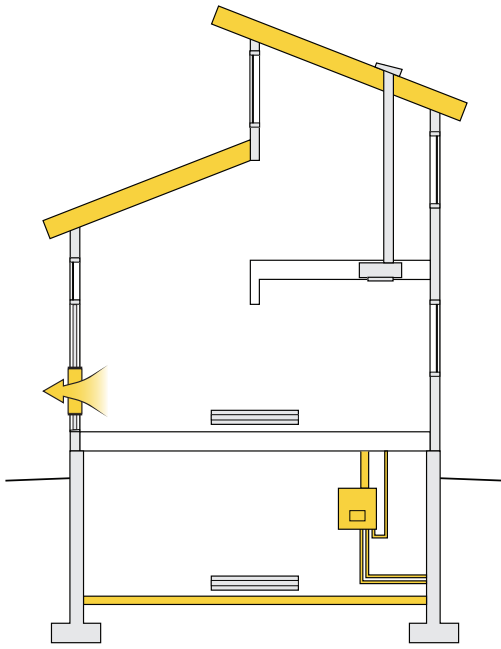

Example Step 2 Compliance for CZ 8

Enclosure	Airtightness (ACH50)	2.5	▲
	Above-Grade Wall	R-22 Effective	■
	Below-Grade Wall	R-19.6 Effective	▼
	Unheated Floors Below Frost Line	R-20 Effective	▲
	Roof	R-100 Effective	▲
	Fenestration and doors	Double-glazed	■
		U-1.6 (SHGC 0.33)	▼
Mechanical	Domestic Hot Water	NG Tankless, 0.8 EF	▲
	Drain Water Heat Recovery		■
	Space Heating	Electric Baseboards, 100% Efficiency	■
	Ventilation Heat Recovery		■

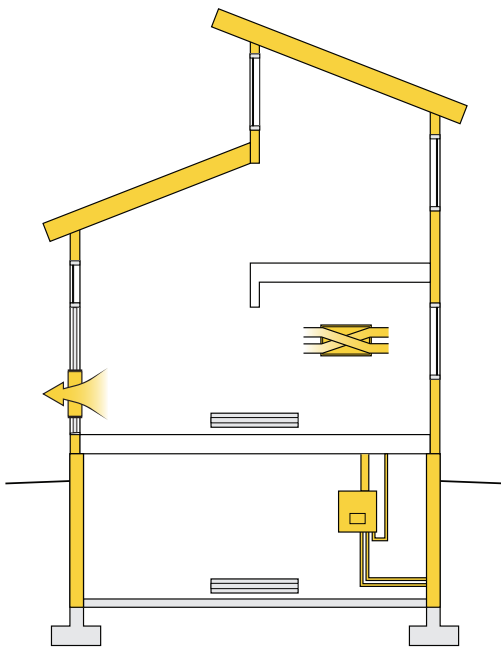

Example Step 2 Compliance for CZ 8

Enclosure	Airtightness (ACH50)	2.5	▲
	Above-Grade Wall	R-24 Effective	▲
	Below-Grade Wall	R-25 Effective	▲
	Unheated Floors Below Frost Line		■
	Roof	R-70 Effective	▲
	Fenestration and doors	Double-glazed	■
		U-1.4 (SHGC 0.33)	■
Mechanical	Domestic Hot Water	NG Tankless, 0.8 EF	▲
	Drain Water Heat Recovery		■
	Space Heating	Electric Baseboards, 100% Efficiency	■
	Ventilation Heat Recovery	84% Efficiency	▲

- No change in performance compared to current code
- ▲ Increase in performance compared to current code
- ▼ Decrease in performance compared to current code

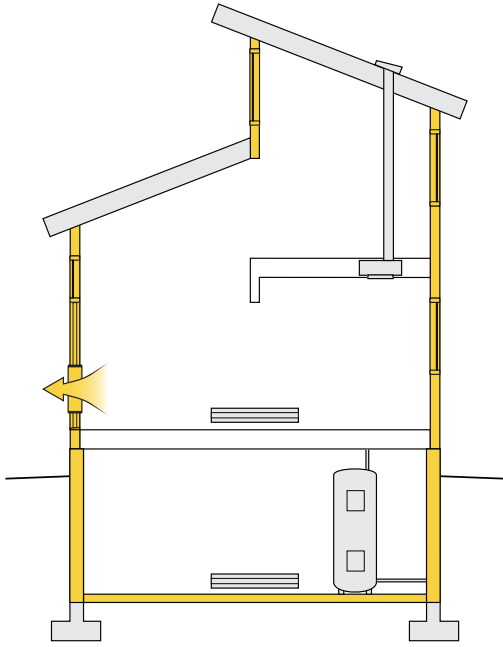

Example Step 3 Compliance for CZ 8

Enclosure	Airtightness (ACH50)	2.5	▲
	Above-Grade Wall	R-40 Effective	▲
	Below-Grade Wall	R-25 Effective	▲
	Unheated Floors Below Frost Line	R-11.1 Effective	▲
	Roof	R-40 Effective	▼
	Fenestration and doors	Triple-glazed U-1.0 (SHGC 0.35)	▲
Mechanical	Domestic Hot Water	Electric Tank, 0.94 EF	
	Drain Water Heat Recovery		
	Space Heating	Electric Baseboards, 100% Efficiency	
	Ventilation Heat Recovery		

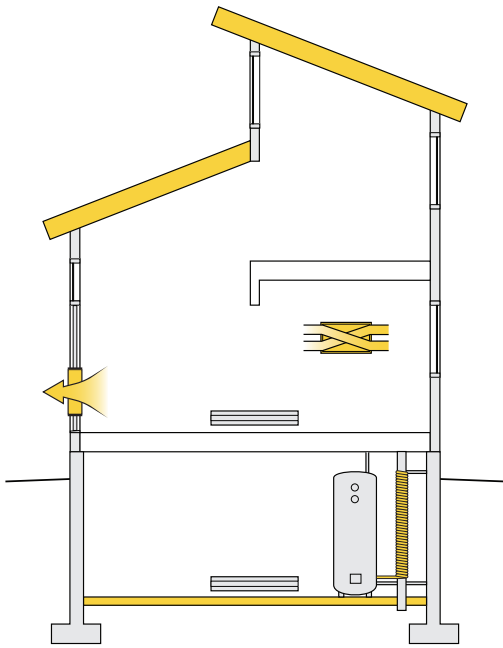

Example Step 3 Compliance for CZ 8

Enclosure	Airtightness (ACH50)	2.5	▲
	Above-Grade Wall	R-22 Effective	
	Below-Grade Wall	R-19.6 Effective	▼
	Unheated Floors Below Frost Line	R-11.1 Effective	▲
	Roof	R-100 Effective	▲
	Fenestration and doors	Double-glazed U-1.6 (SHGC 0.33)	▼
Mechanical	Domestic Hot Water	NG Tank, 0.67 EF	
	Drain Water Heat Recovery	42% Efficient	▲
	Space Heating	Electric Baseboards, 100% Efficiency	
	Ventilation Heat Recovery	60% Efficiency	▲

- No change in performance compared to current code
- ▲ Increase in performance compared to current code
- ▼ Decrease in performance compared to current code

This page is intentionally left blank

Appendix D: Mock-Up Build Instructions

Split-Insulated Wall Assembly | Thin Exterior Insulation

Non-Flange Window | Exterior Air Barrier Approach

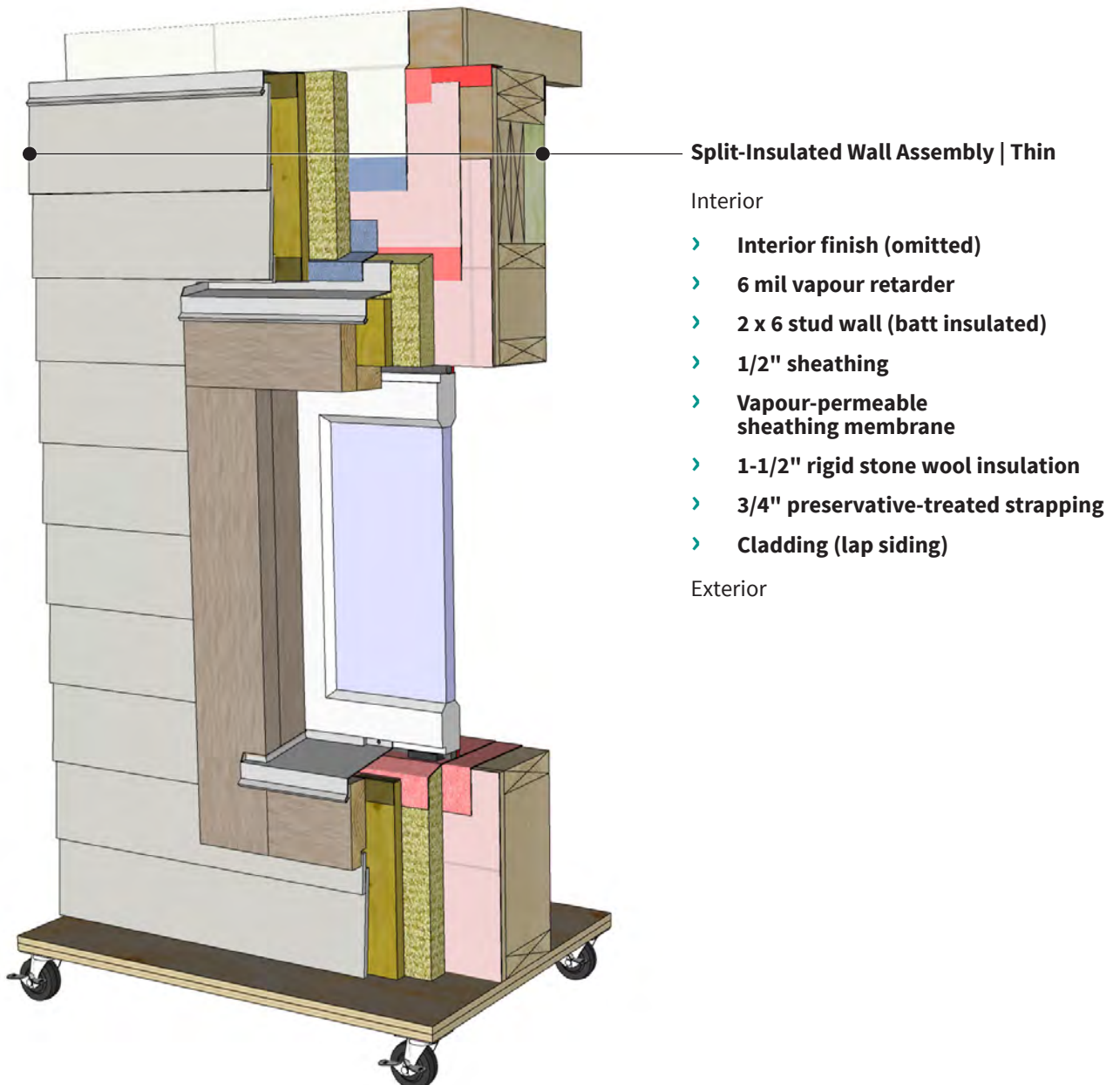

Materials & Tools

Materials

- › 30 lf. 2x6 lumber for exterior wall framing
- › 36 lf. 2x4 lumber for interior wall & shipping framing
- › 3 lf. 2x8 lumber for header framing
- › 18 lf. 3" wide x 3/4" thick preservative-treated plywood rainscreen strapping
- › 48" x 96" 1/2" plywood sheet
- › 15 lf. 7-1/4" wide fibre-cement lap siding
- › 6 lf. 5-1/2" wide 5/4 trim board
- › **(2)** 24" x 48" 1-1/2" thick rigid stone wool (≥ 11 psf density)
- › 4 lf. insect screen
- › 4 lf. 9" wide 24 gauge flashing flatstock
- › 12" x 24" window (W x H, with attachment accessories as required)
- › **(4)** 3" non-marking lockable casters
- › 4 lf. backer rod for 1/2" gap
- › Contractor-grade silicone sealant
- › 5 lf. 9" wide impermeable self-adhered membrane
- › 9 lf. 2-1/2" wide high-performance air barrier tape
- › 36" x 60" 6 mil polyethylene sheet
- › 6 lf. 2x6 stud batt insulation
- › Assorted window shims
- › **(3)** Hurricane ties
- › 48" x 72" permeable sheathing membrane
- › 2-1/2" wide acrylic sheathing tape
- › Assorted fasteners including:
 - Framing nails
 - 3" wood screws
 - Cladding nails
 - Staples

Tools

- › Standard tools for framing, cladding and flashing work
- › 24" sheet metal brake
- › Staple gun
- › Sealant gun
- › Membrane roller
- › Stone wool insulation cutter
- › Utility knife

Framing Cut List

Base Platform (1/2" plywood)

- › (2) 24" x 33" rectangle

Exterior Wall (2x6 lumber unless noted otherwise)

- › 33" bottom plate
- › (2) 10-1/2" cripple
- › 42-3/4" trimmer stud
- › 51-1/2" king stud
- › 51-1/2" end stud
- › 16-1/2" sill
- › 16-1/2" head trimmer
- › (2) 4-1/4" cripple (head)
- › 18" header plate
- › 33" top plate
- › 6" top plate
- › 12-1/2" top plate
- › 11" top plate
- › 51-1/2" interior wall backer stud
- › (2) 18" 2x8 header

Interior Wall, Ceiling & Shipping (2x4 lumber)

- › 8" bottom plate
- › 8" top plate
- › 13-1/2" overlapping top plate
- › (2) 51-1/2" studs
- › (3) 13-1/2" ceiling joists
- › (2) 33" shipping horizontal members
- › (3) 60-1/2" shipping vertical members

Sheathing (1/2" plywood)

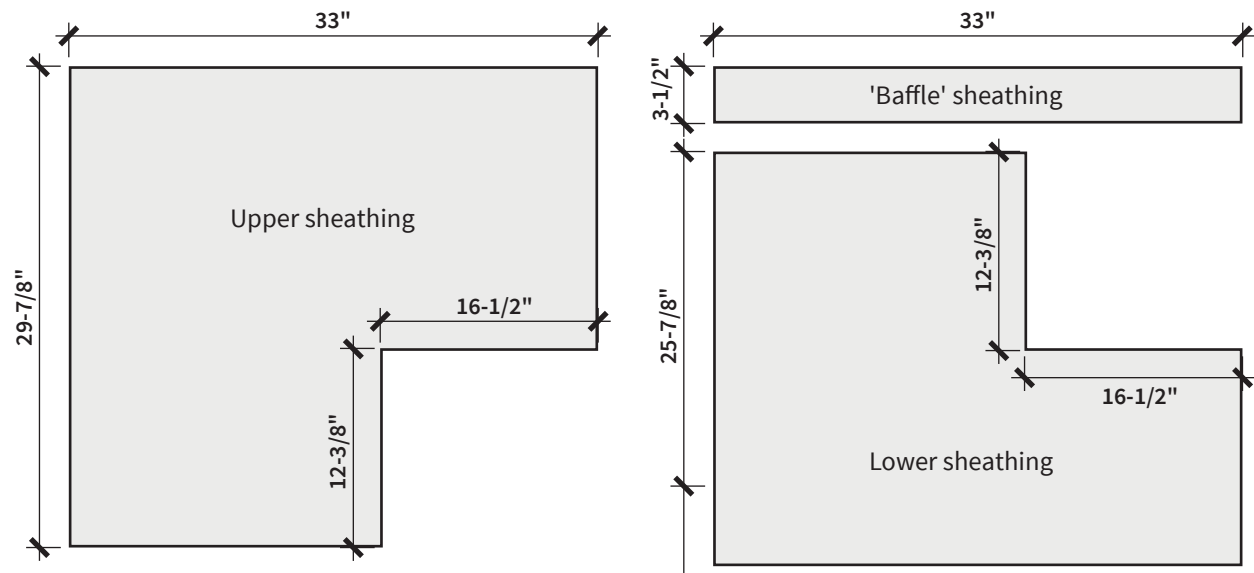

Wall Sheathing



Interior Wall Framing

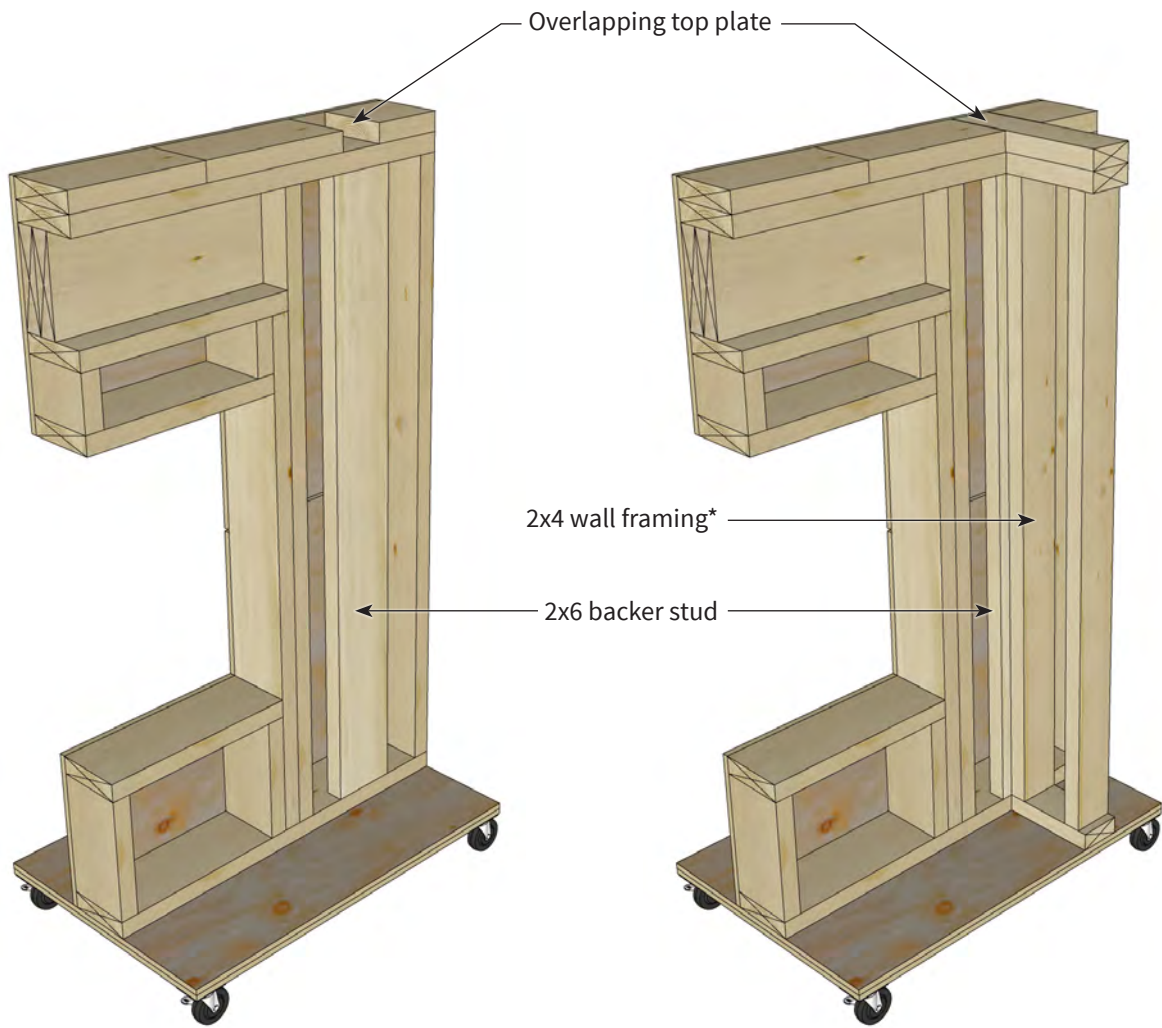

*Interior polyethylene pre-strip behind dividing wall may not be required when the exterior wall air barrier approach is used.

Top Plate Air Barrier Tape - Ceiling Interior Air Barrier Transition

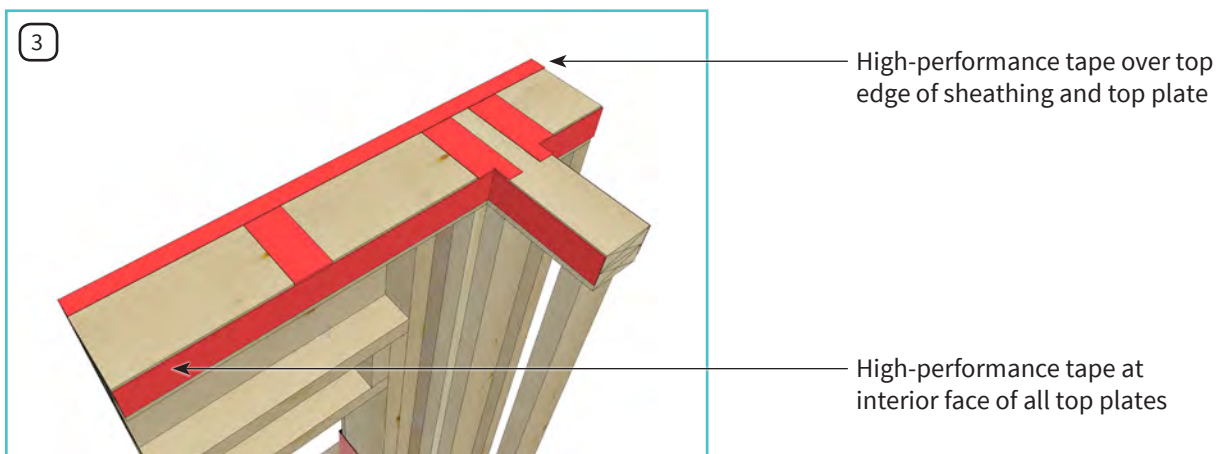
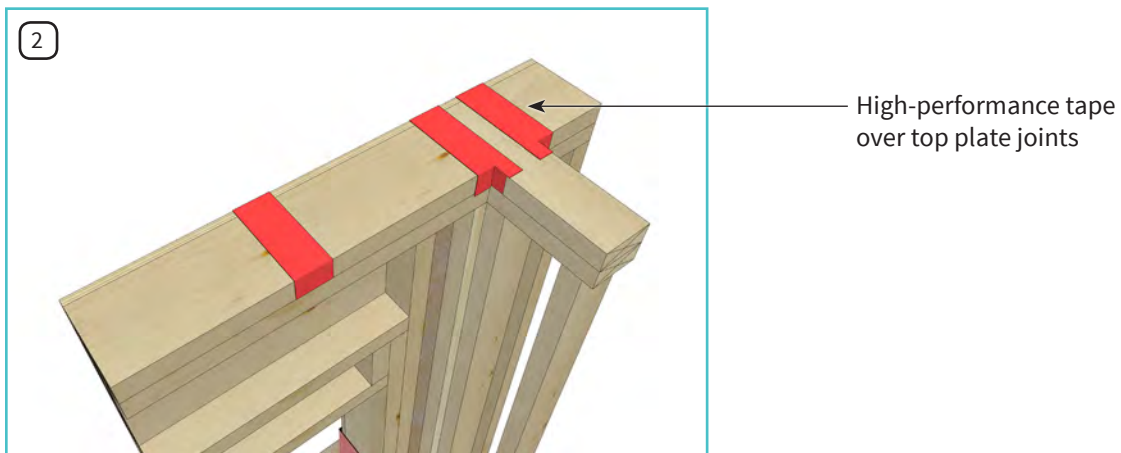
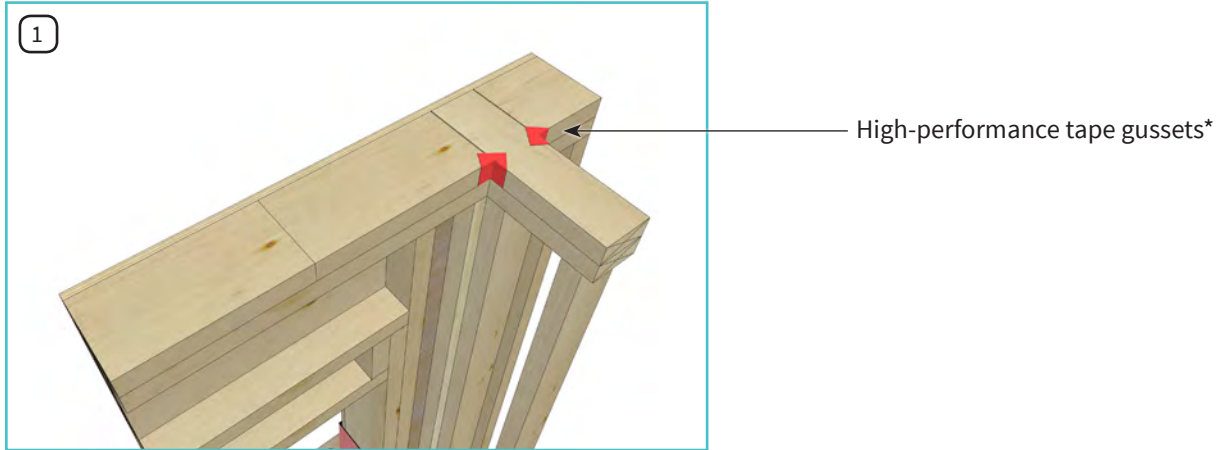

*Red indicates air barrier components, not necessarily product colour.

Roof Framing

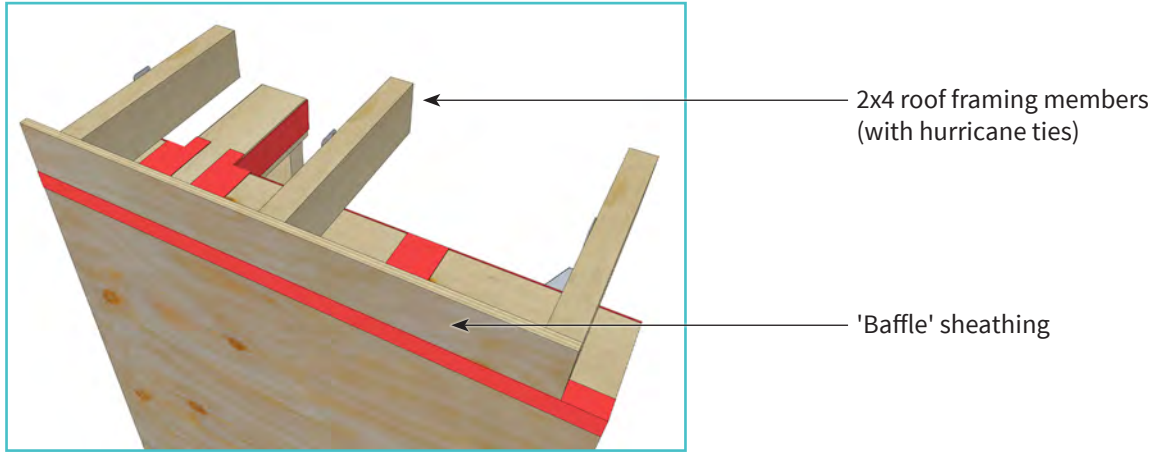

Window Sill Sheathing Membrane Pre-Strip

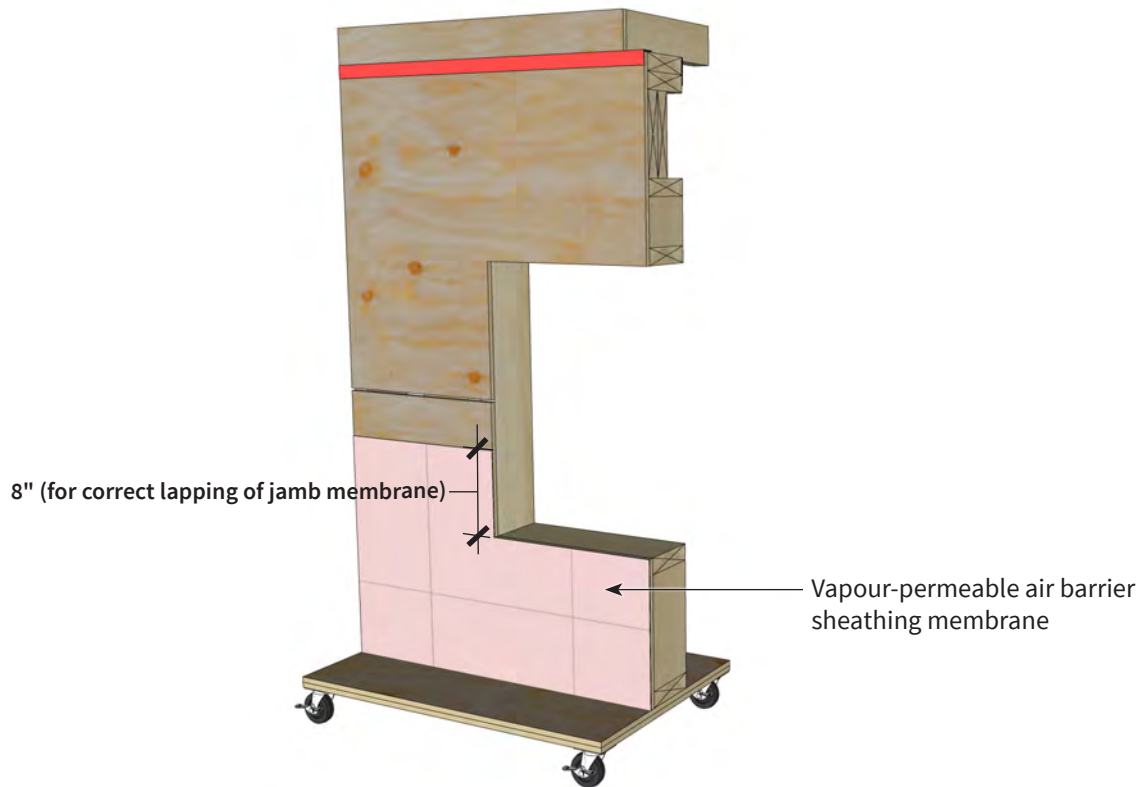

Window Self-Adhered Membrane

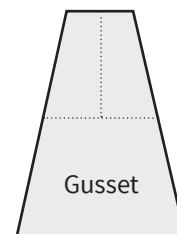
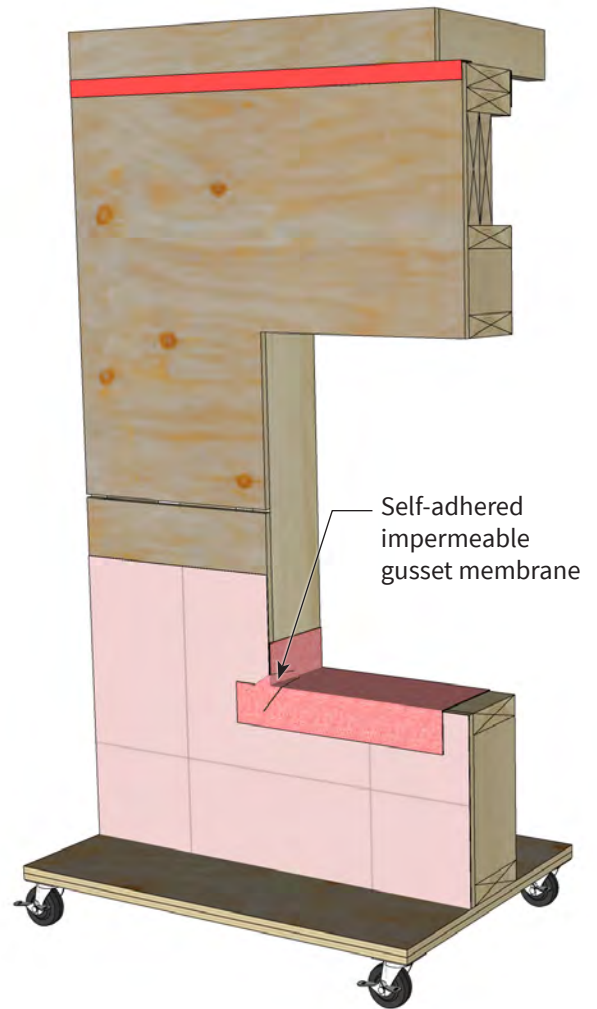
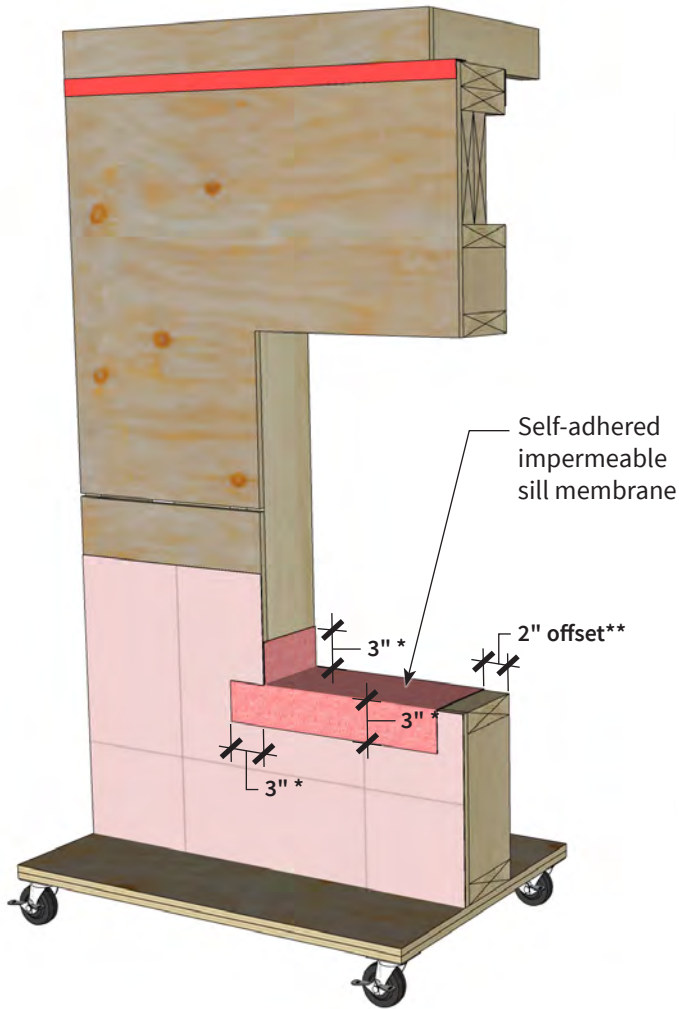

*Recommended dimension for correct membrane lapping.

**Recommended dimension for offset layering.

Window Self-Adhered Membrane (Continued)

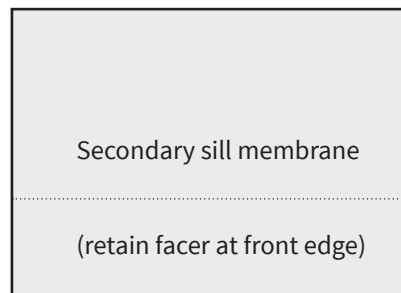
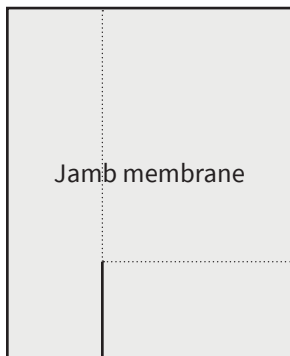
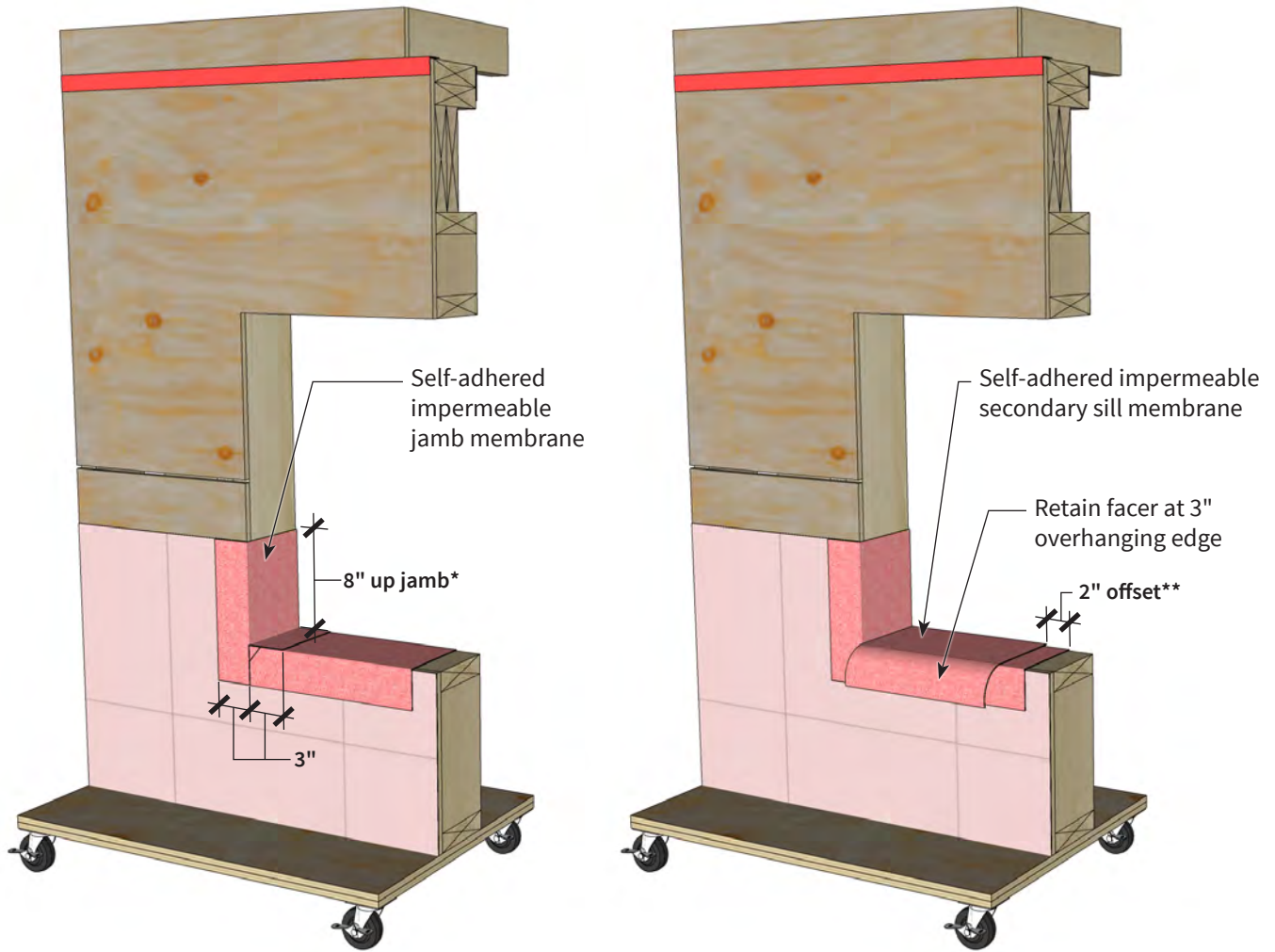

*Recommended dimension for correct membrane lapping.

**Recommended dimension for offset layering.

Window Pre-Strip Sheathing Membrane

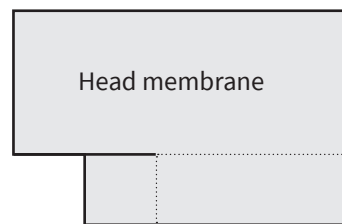
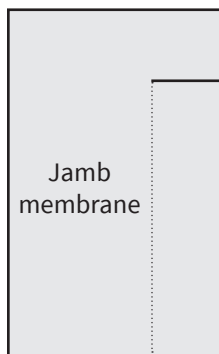
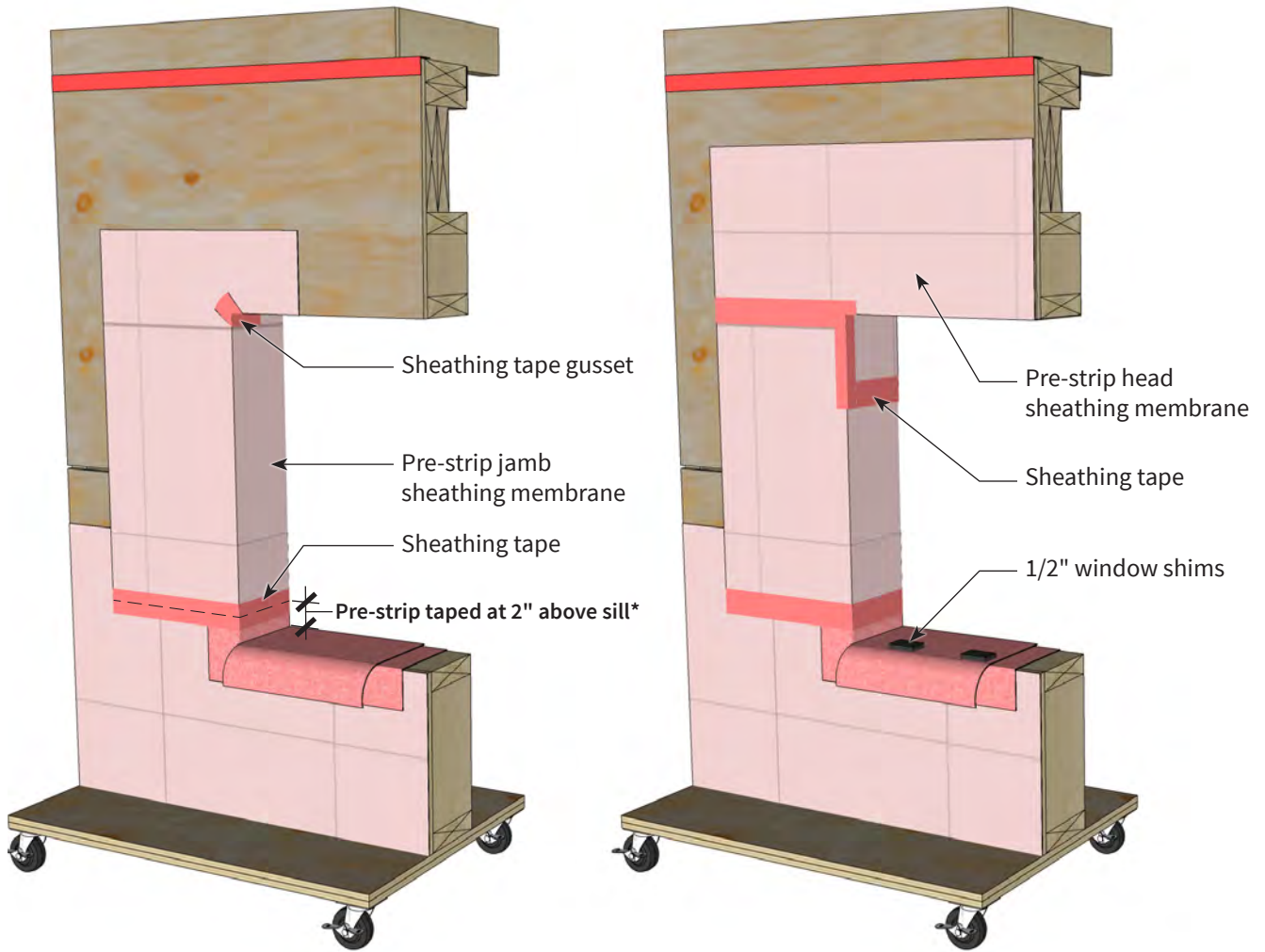

*Recommended dimension for correct membrane lapping.

Window Installation

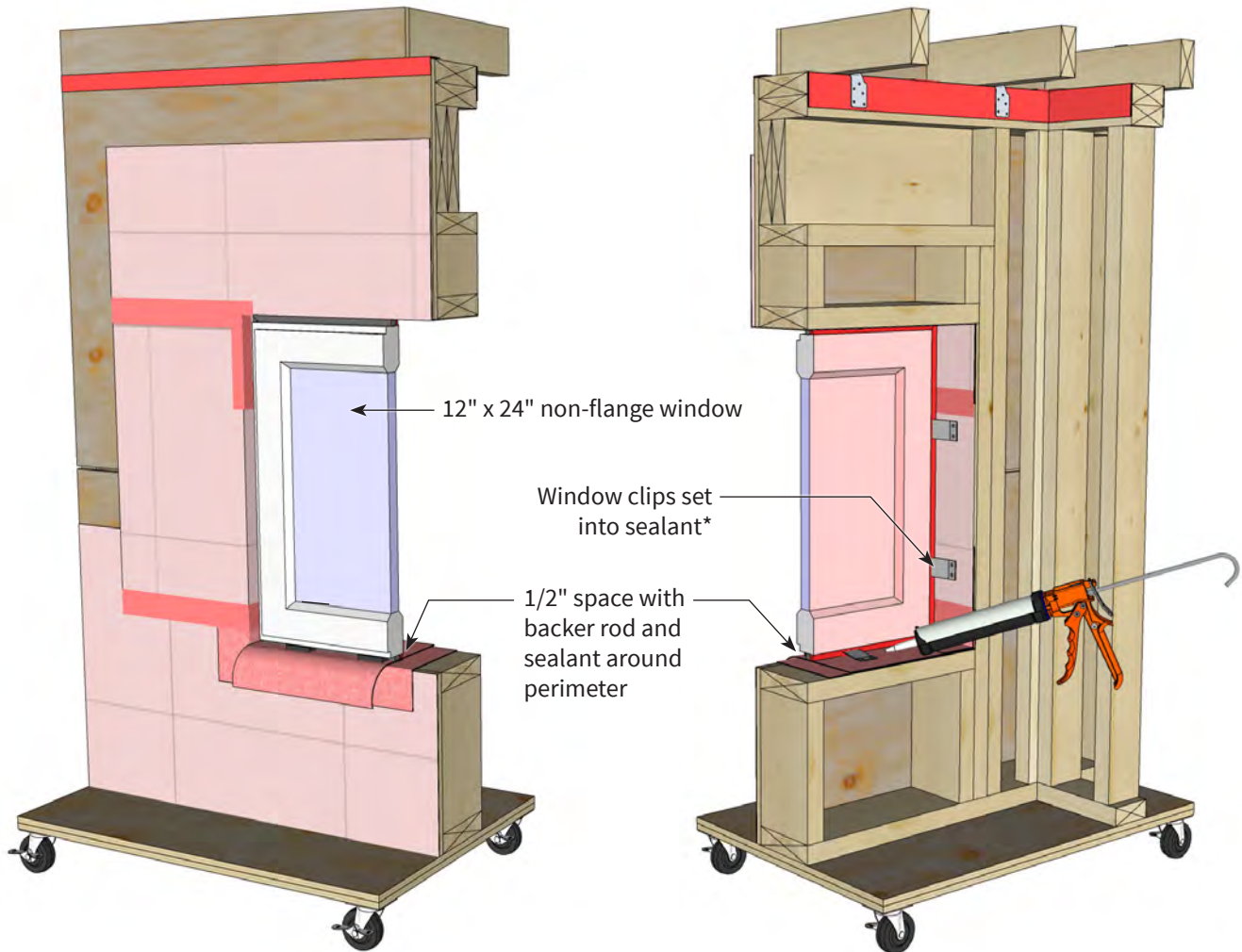

*As per manufacturer's installation requirements.

Field Membrane & Insulation

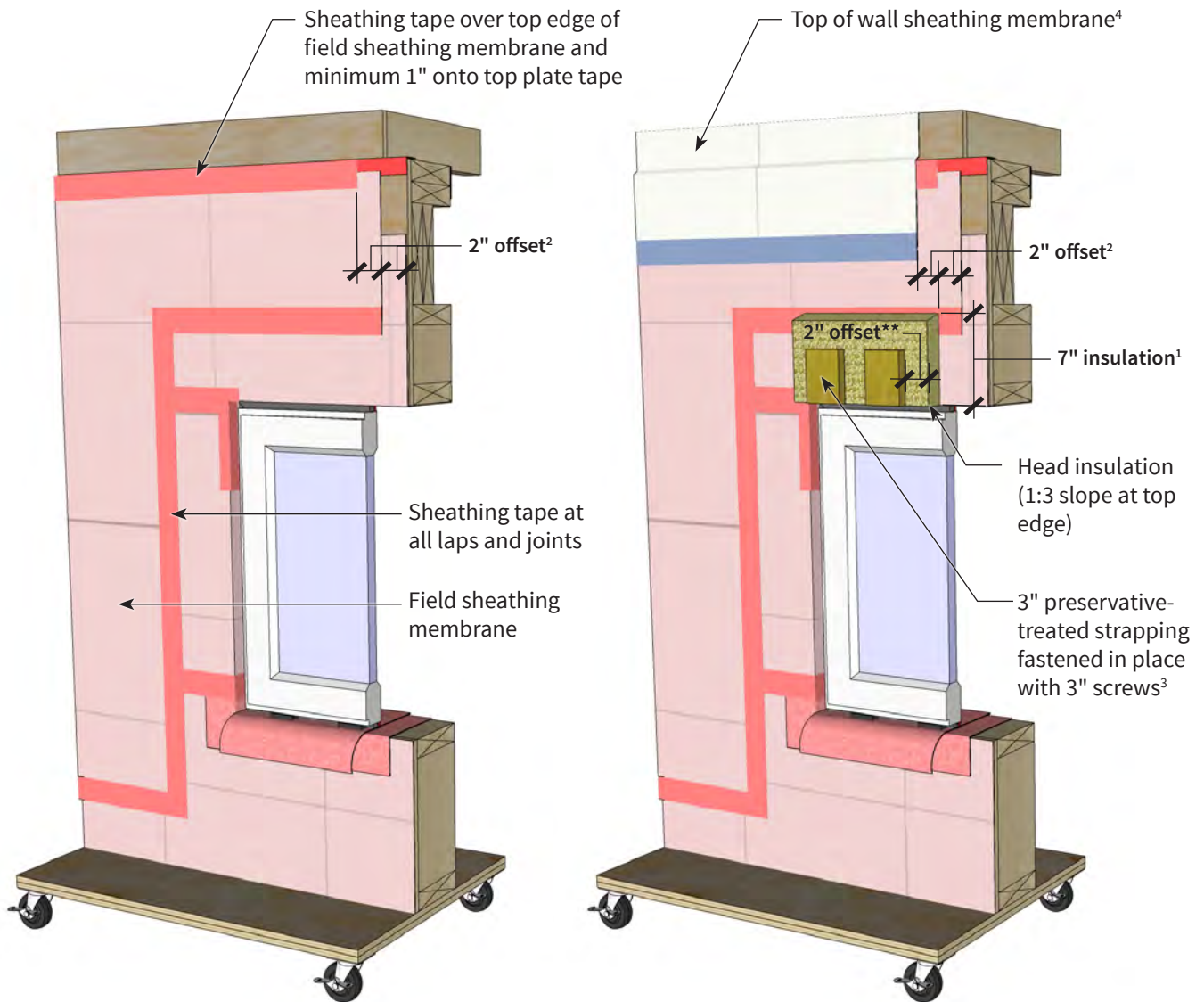

¹Varies based on trim and flashing dimensions; recommended dimension for use with 5-1/2" trim board at head.

²Recommended dimension for offset layering.

³Strapping spaced to retain mockup insulation as needed.

⁴The top of wall sheathing membrane above the top plate functions only as the water-resistive barrier in this assembly and must be installed following the manufacturer's instructions.

Insulation & Strapping

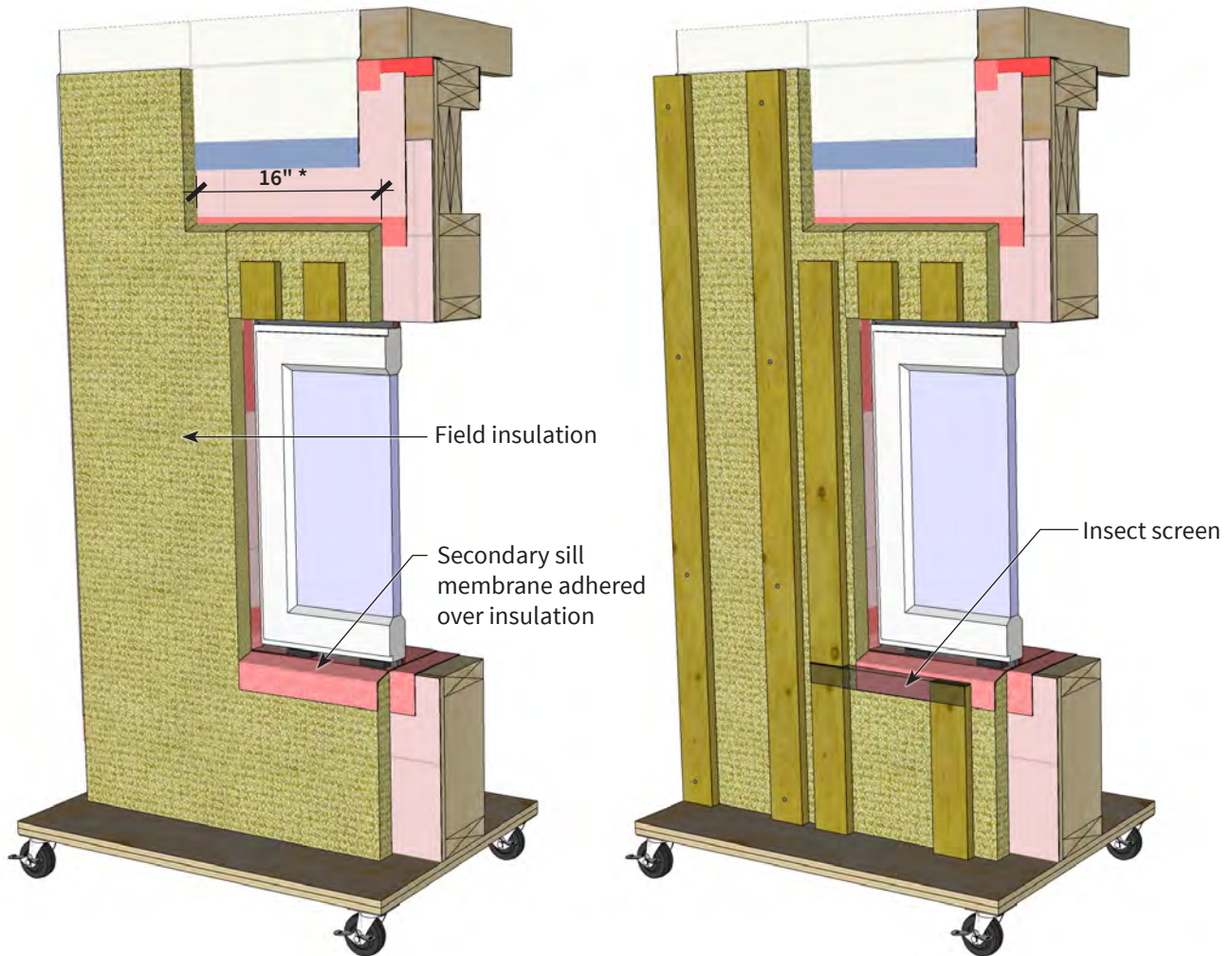

*Varies based on trim used; recommended dimension to align with outside edge of 5-1/2" trim board at jamb inset 1-1/2" over window.

Flashing & Trim

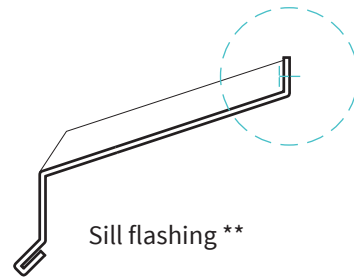
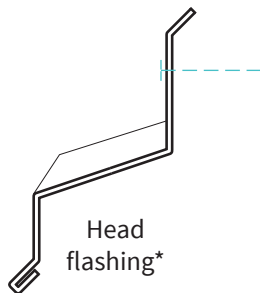
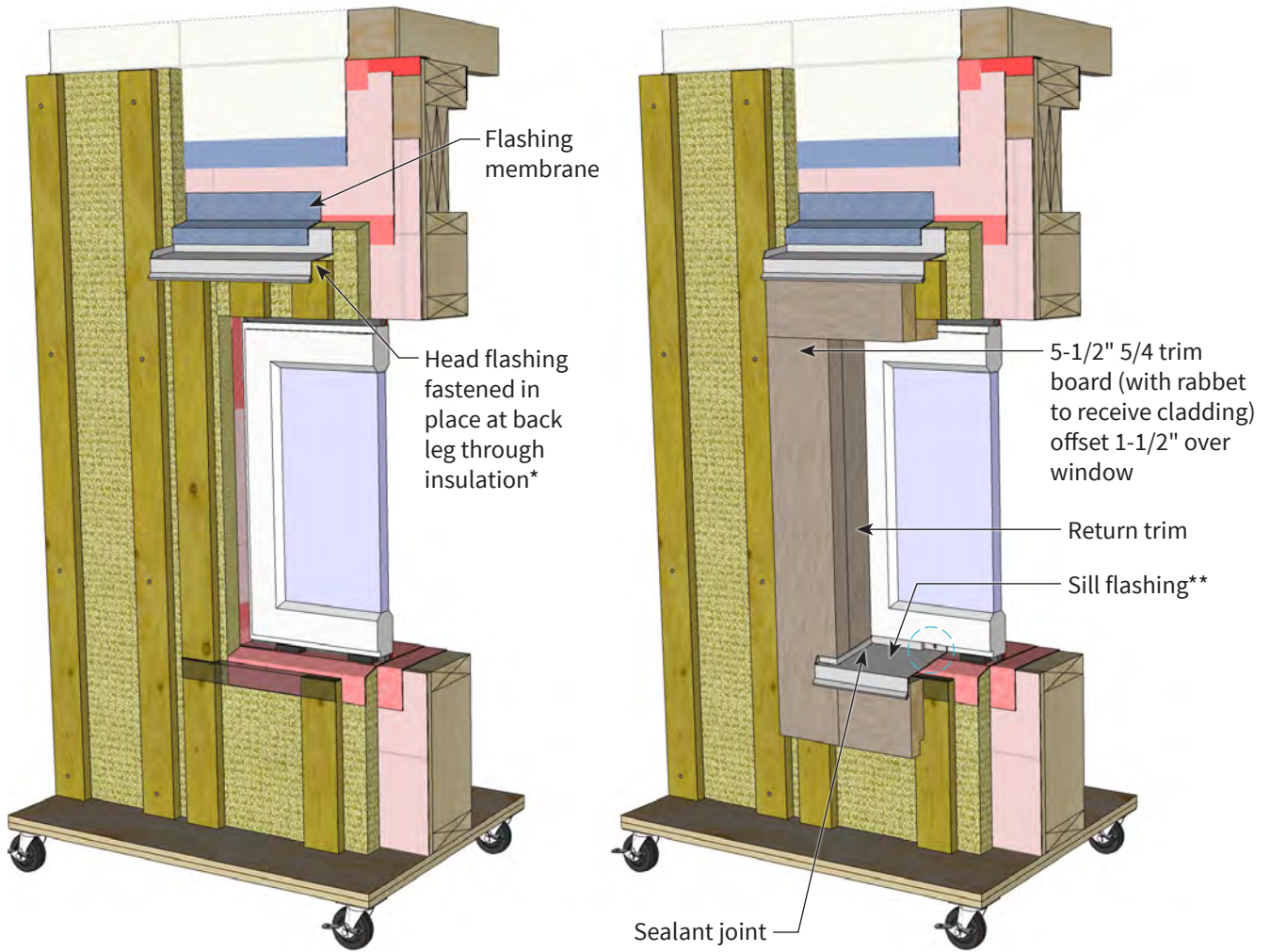

*Flashing profile varies based on trim thickness.

**Sill flashing attachment to window varies; profile shown assumes back leg attachment to front face of window with screws. Other options include attachment with double-sided tape and sealant, or using an extended return beneath the window profile.

Strapping & Cladding

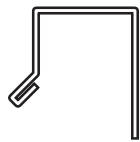
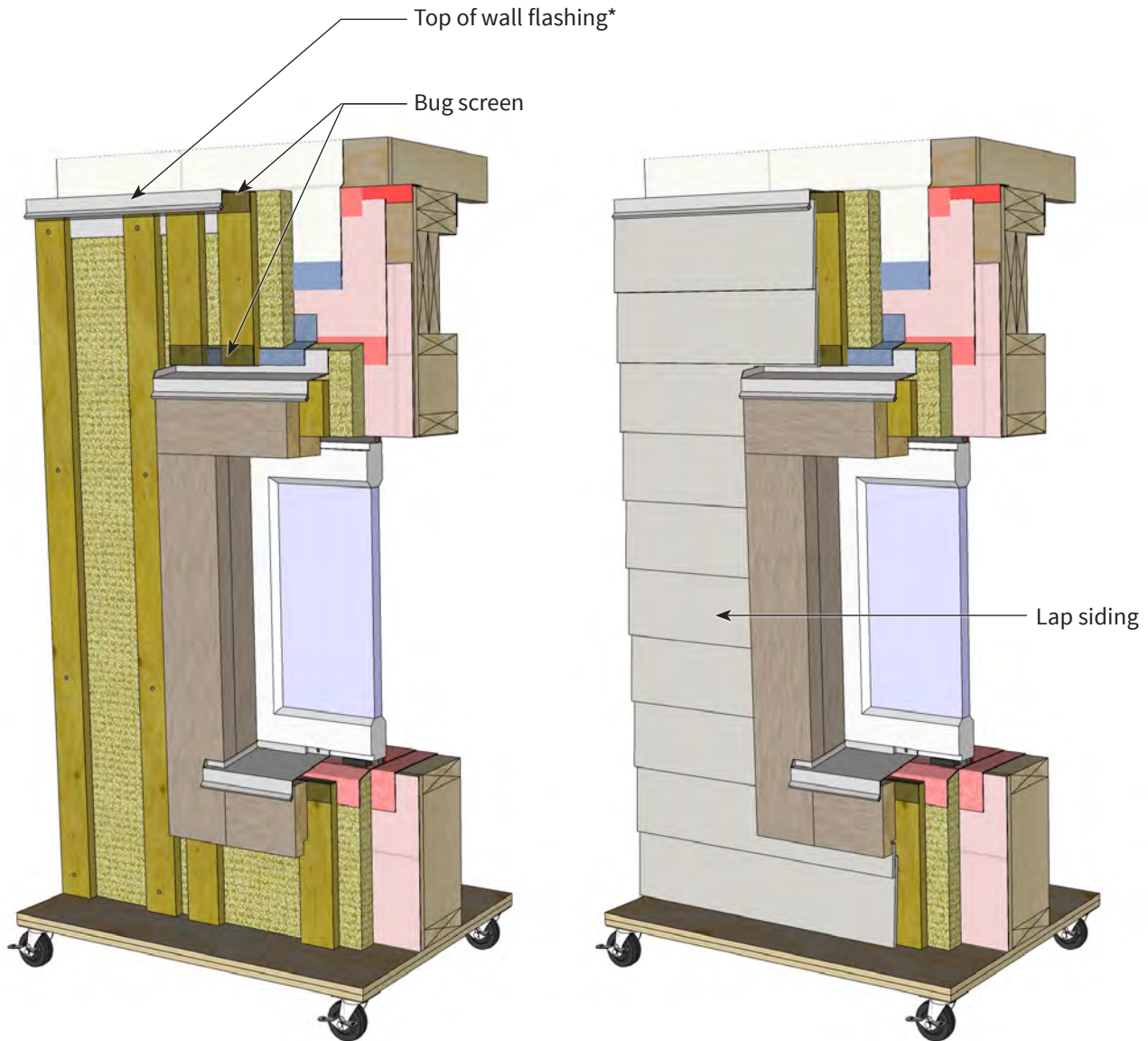

Top of wall flashing*

*Profile varies based on trim/cladding used; must be shaped to cap-off top of rainscreen cavity but still allow ventilation. Attached by slipping between back of strapping and front face of exterior insulation.

Interior Insulation & Polyethylene

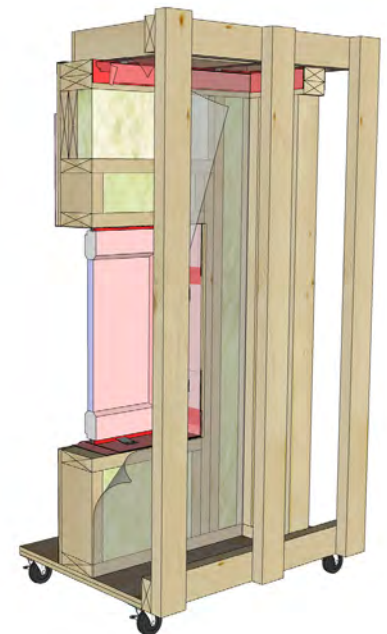
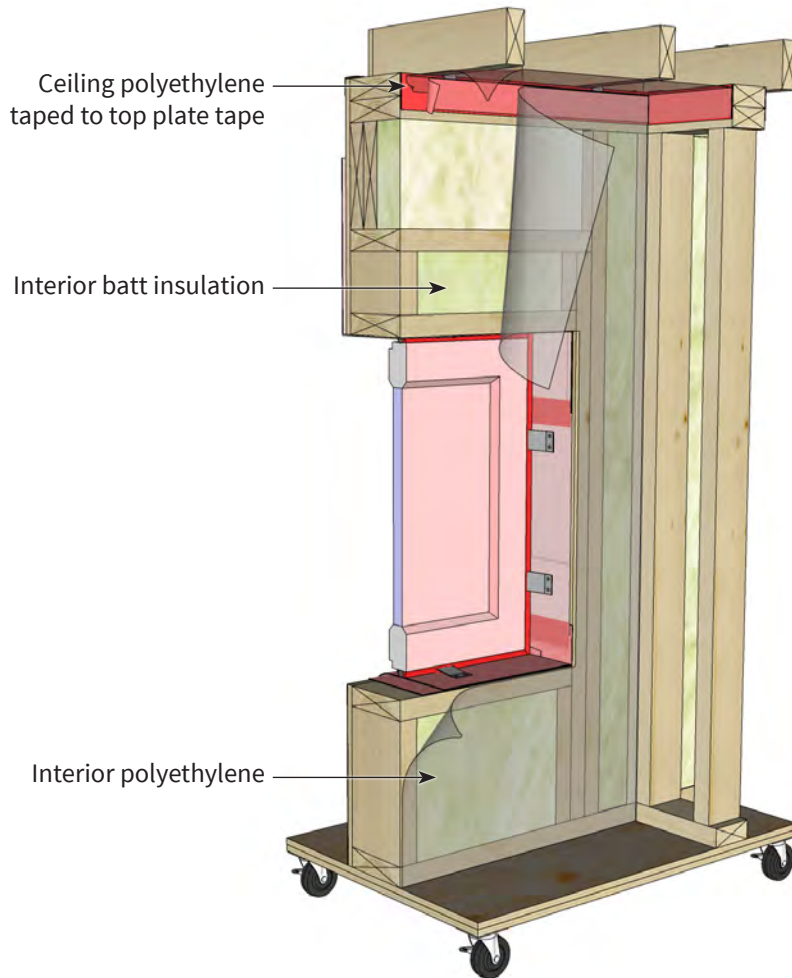

2x4 framing for horizontal transport

This page is intentionally left blank

Split-Insulated Wall Assembly | Thick Exterior Insulation

Non-Flange Window | Exterior Air Barrier Approach

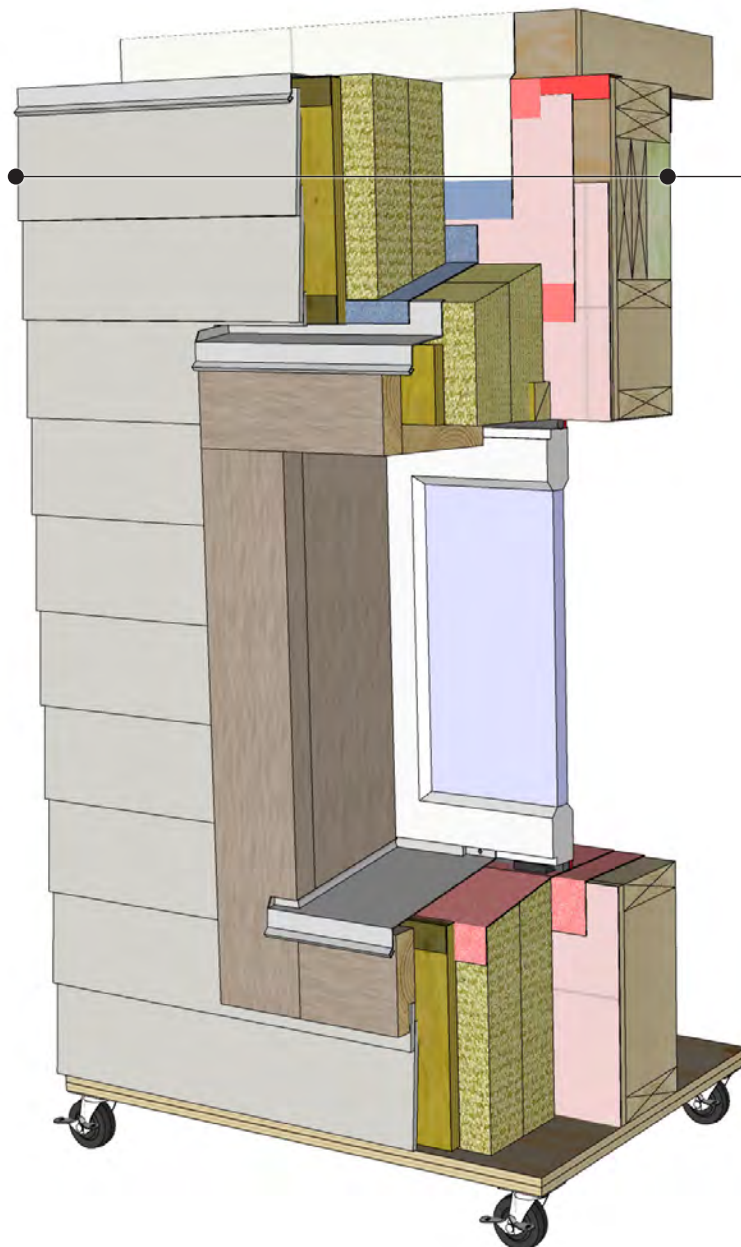

Split-Insulated Wall Assembly | Thin

Interior

- › Interior finish (omitted)
- › 6 mil vapour retarder
- › 2 x 6 stud wall (batt insulated)
- › 1/2" sheathing
- › Vapour-permeable sheathing membrane
- › 6" rigid stone wool insulation
- › 3/4" preservative-treated strapping
- › Cladding (lap siding)

Exterior

Materials & Tools

Materials

- › 30 lf. 2x6 lumber for exterior wall framing
- › 36 lf. 2x4 lumber for interior wall & shipping framing
- › 3 lf. 2x8 lumber for header framing
- › 18 lf. 3" wide x 3/4" thick preservative-treated plywood rainscreen strapping
- › 48" x 96" 1/2" plywood sheet
- › 15 lf. 7-1/4" wide fibre-cement lap siding
- › 6 lf. 5-1/2" wide 5/4 trim board
- › **(8)** 24" x 48" 3" thick rigid stone wool (≥ 11 psf density)
- › 4 lf. insect screen
- › 4 lf. 9" wide 24 gauge flashing flatstock
- › 12" x 24" window (W x H, with attachment accessories as required)
- › **(4)** 3" non-marking lockable casters
- › 4 lf. backer rod for 1/2" gap
- › Contractor-grade silicone sealant
- › 5 lf. 9" wide impermeable self-adhered membrane
- › 9 lf. 2-1/2" wide high-performance air barrier tape
- › 36" x 60" 6 mil polyethylene sheet
- › 6 lf. 2x6 stud batt insulation
- › Assorted window shims
- › **(3)** Hurricane ties
- › 48" x 72" permeable sheathing membrane
- › 2-1/2" wide acrylic sheathing tape
- › Assorted fasteners including:
 - Framing nails
 - 8" wood screws
 - Cladding nails
 - Staples

Tools

- › Standard tools for framing, cladding and flashing work
- › 24" sheet metal brake
- › Staple gun
- › Sealant gun
- › Membrane roller
- › Stone wool insulation cutter
- › Utility knife

Framing Cut List

Base Platform (1/2" plywood)

- › (2) 24" x 33" rectangle

Exterior Wall (2x6 lumber unless noted otherwise)

- › 33" bottom plate
- › (2) 10-1/2" cripple
- › 42-3/4" trimmer stud
- › 51-1/2" king stud
- › 51-1/2" end stud
- › 16-1/2" sill
- › 16-1/2" head trimmer
- › (2) 4-1/4" cripple (head)
- › 18" header plate
- › 33" top plate
- › 6" top plate
- › 12-1/2" top plate
- › 11" top plate
- › 51-1/2" interior wall backer stud
- › (2) 18" 2x8 header

Interior Wall, Ceiling & Shipping (2x4 lumber)

- › 8" bottom plate
- › 8" top plate
- › 13-1/2" overlapping top plate
- › (2) 51-1/2" studs
- › (3) 13-1/2" ceiling joists
- › (2) 33" shipping horizontal members
- › (3) 60-1/2" shipping vertical members

Sheathing (1/2" plywood)

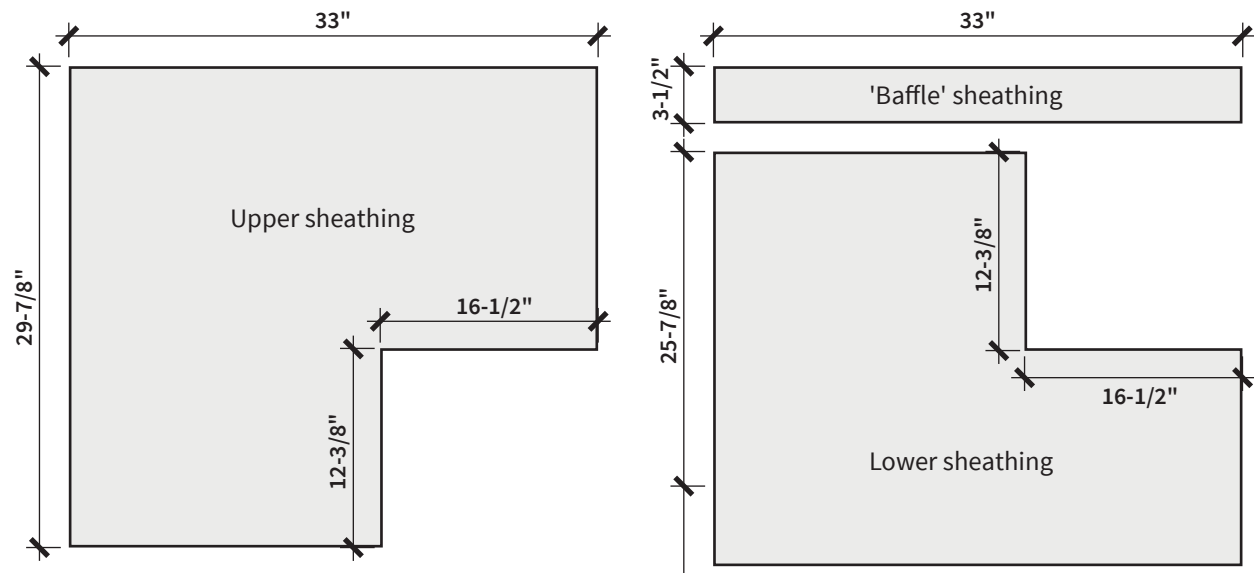

Exterior Wall Framing

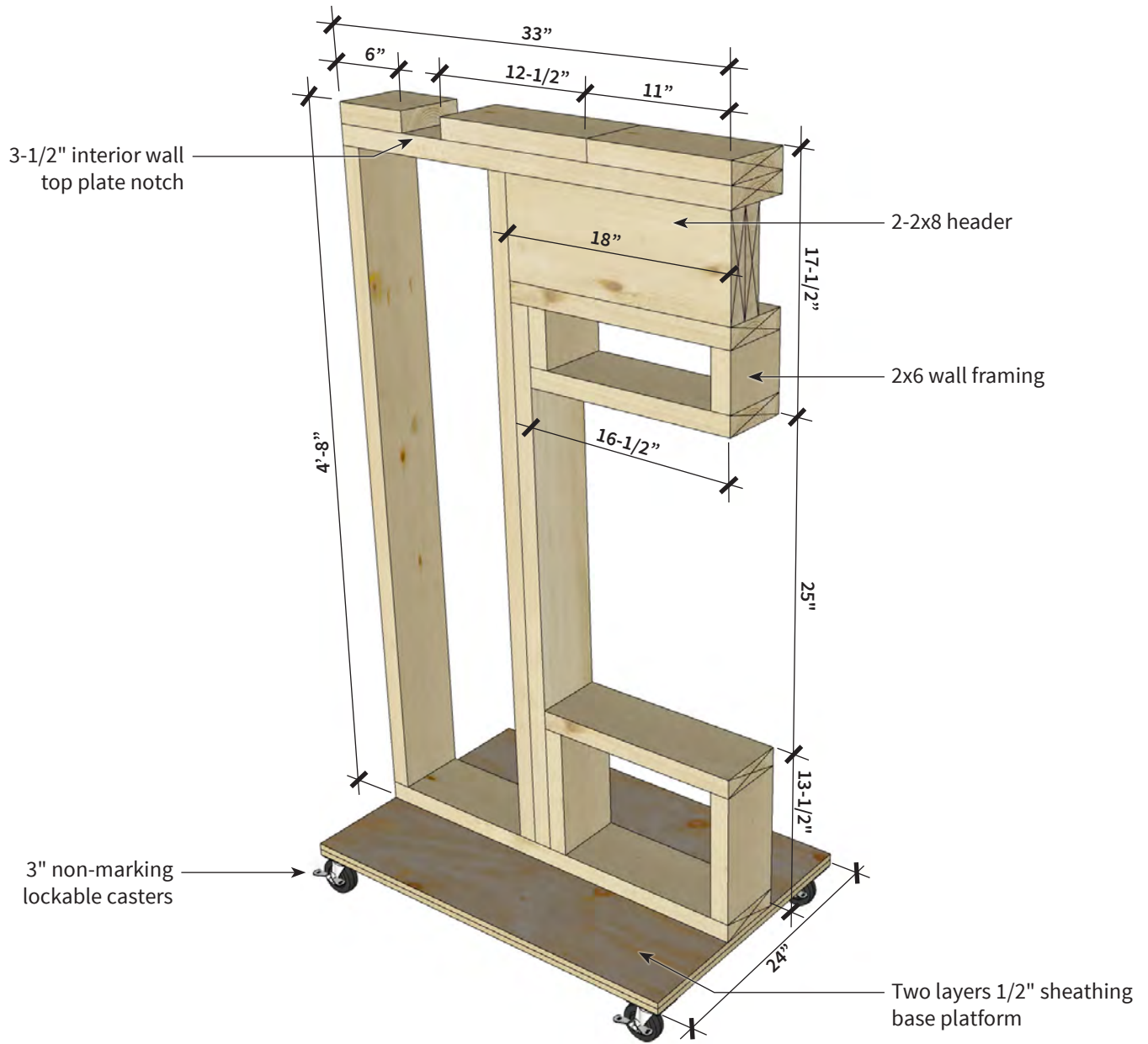

Wall Sheathing



Interior Wall Framing

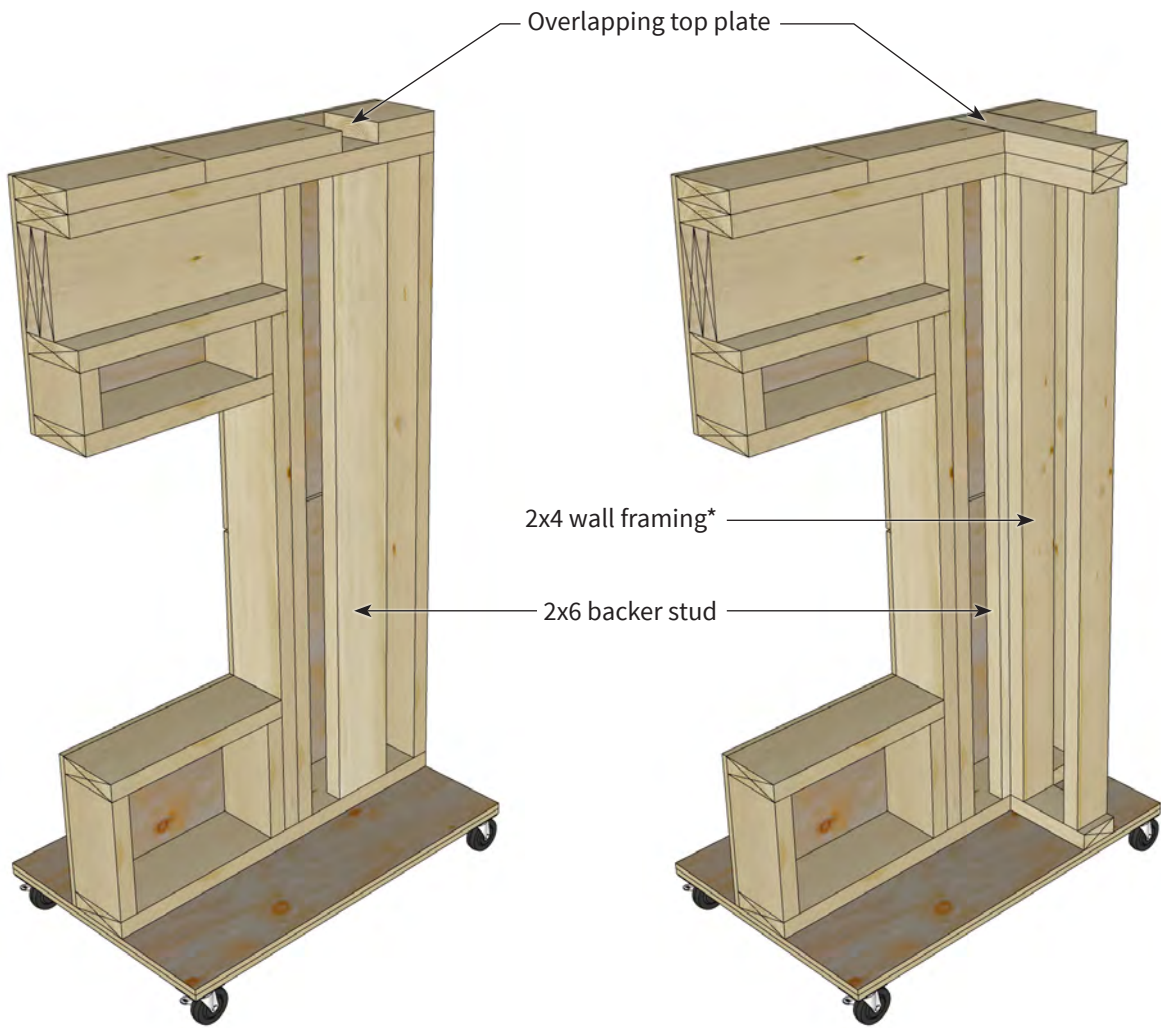

*Interior polyethylene pre-strip behind dividing wall may not be required when the exterior wall air barrier approach is used.

Top Plate Air Barrier Tape - Ceiling Interior Air Barrier Transition

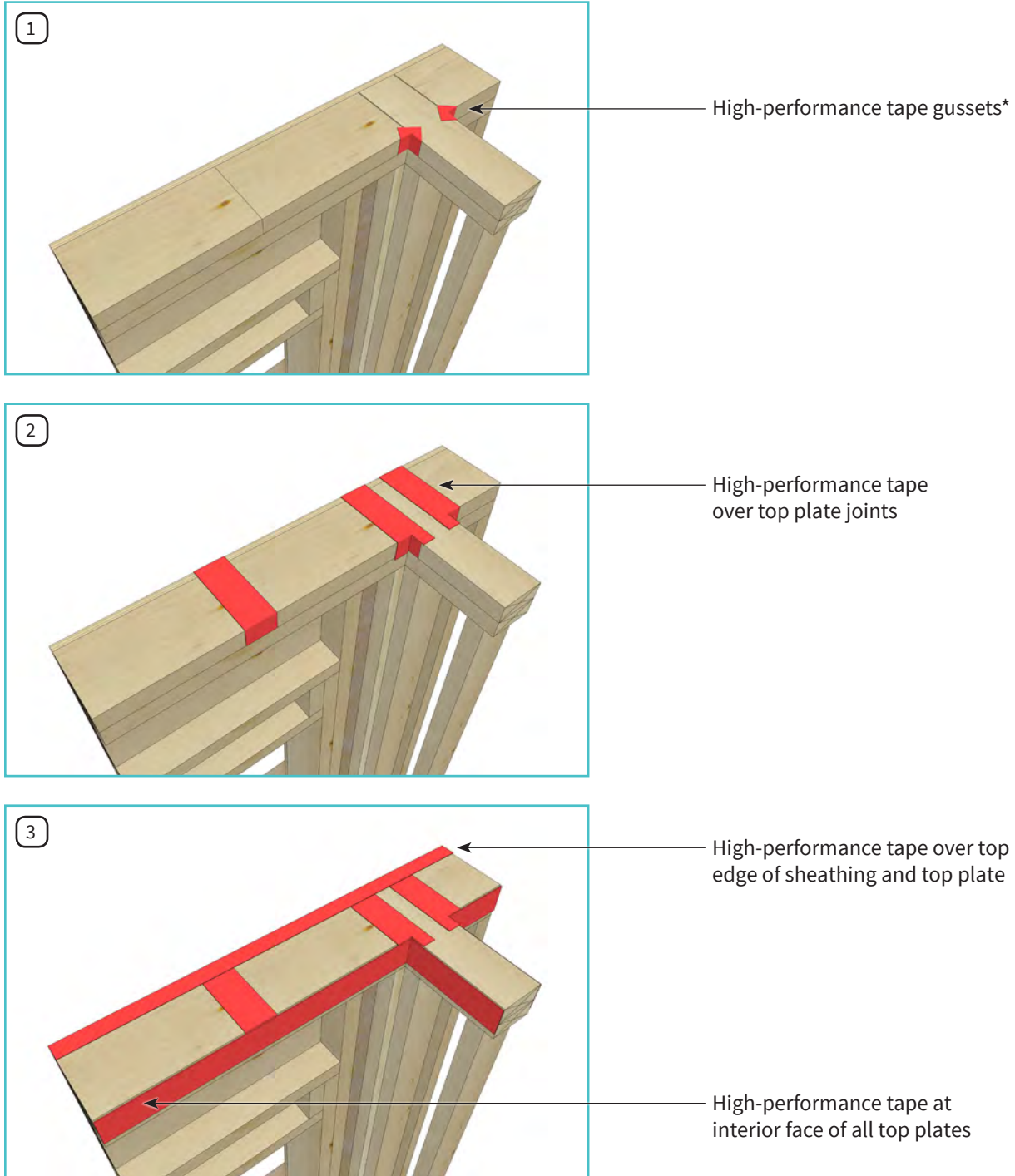

*Red indicates air barrier components, not necessarily product colour.

Roof Framing

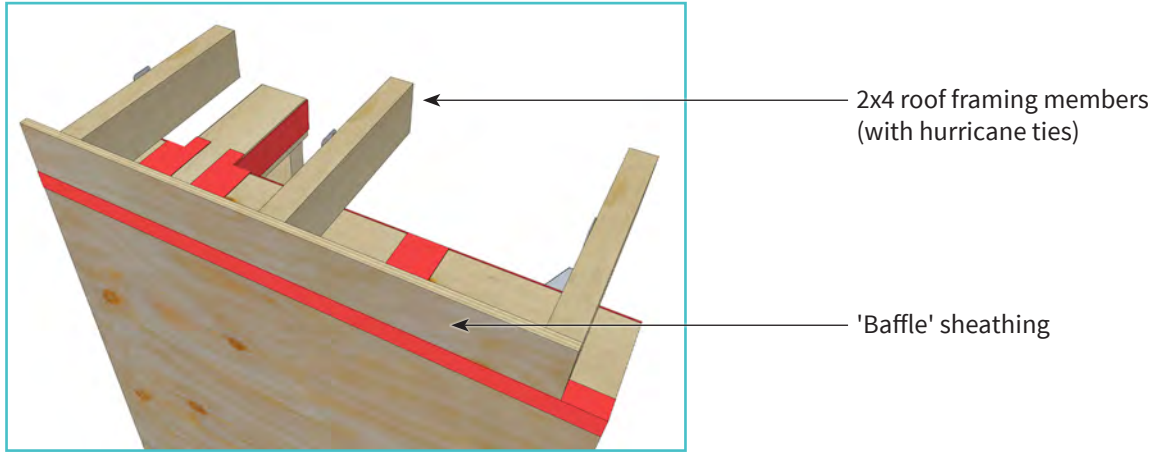

Window Sill Sheathing Membrane Pre-Strip

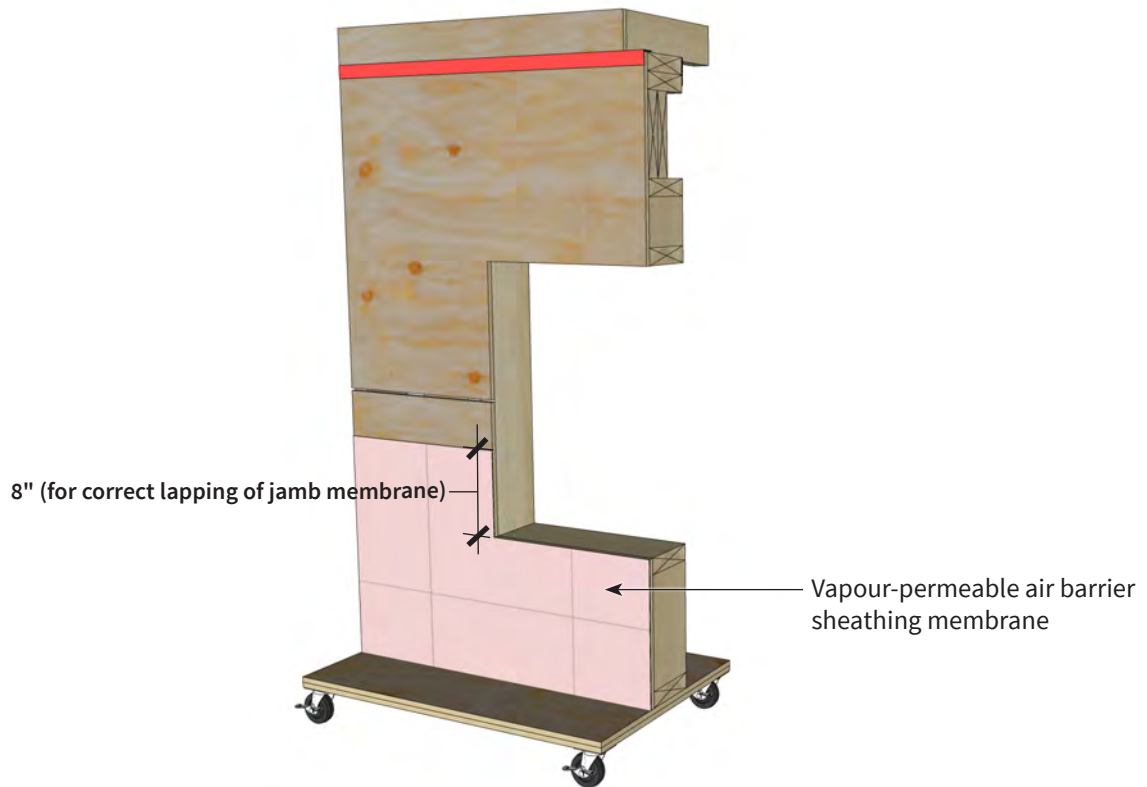

Window Self-Adhered Membrane

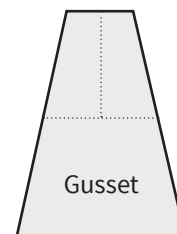
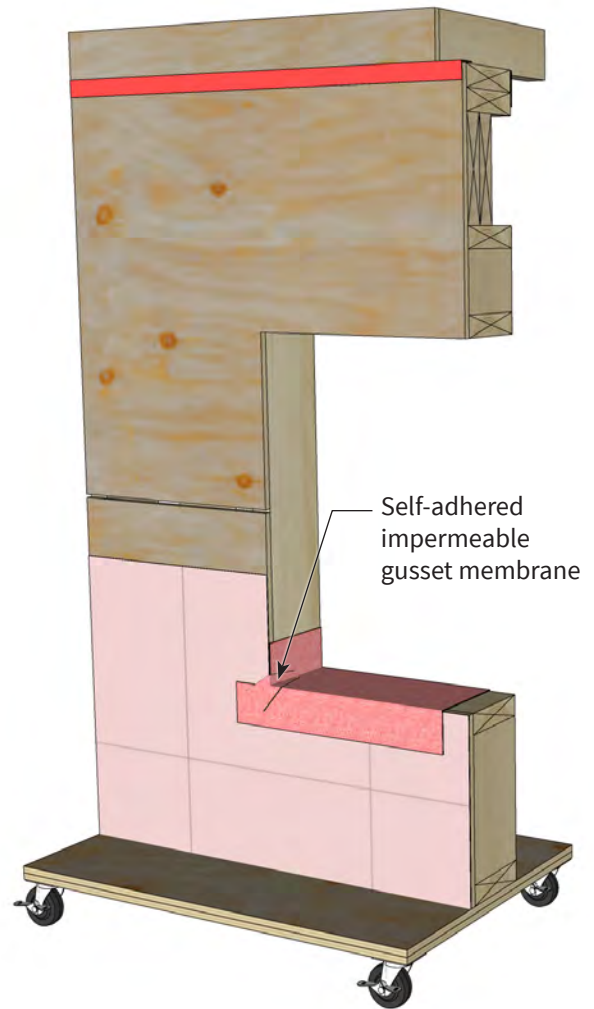
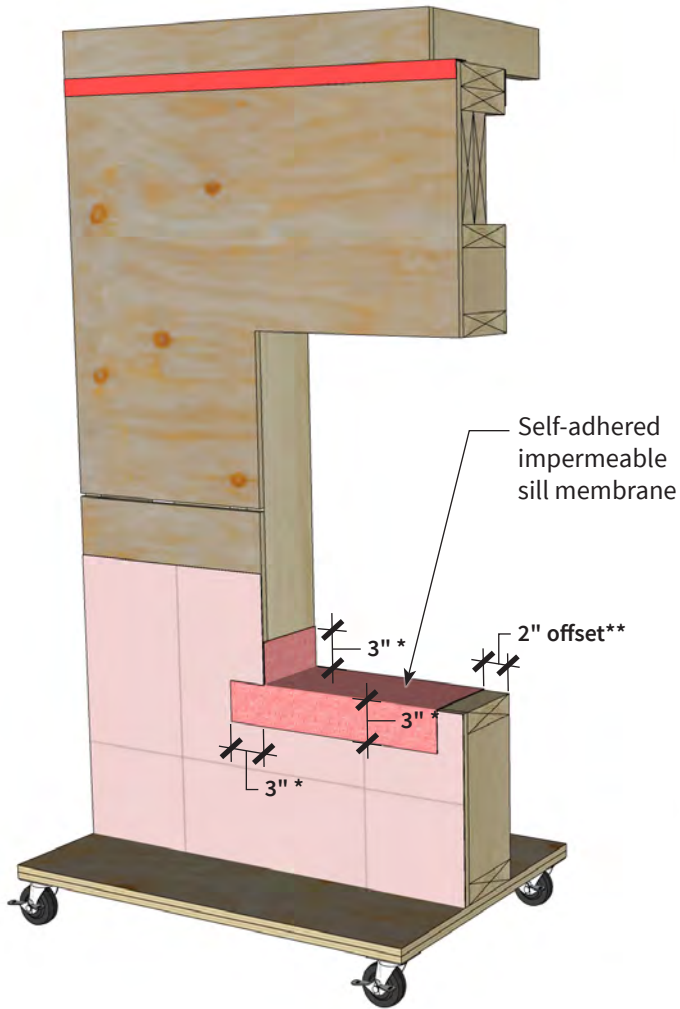

*Recommended dimension for correct membrane lapping.

**Recommended dimension for offset layering.

Window Self-Adhered Membrane (Continued)

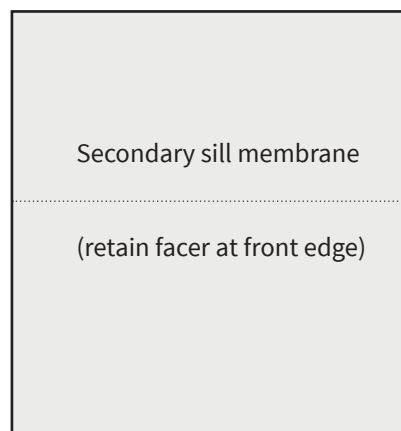
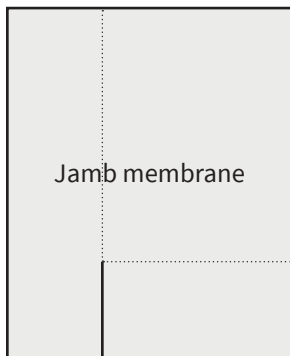
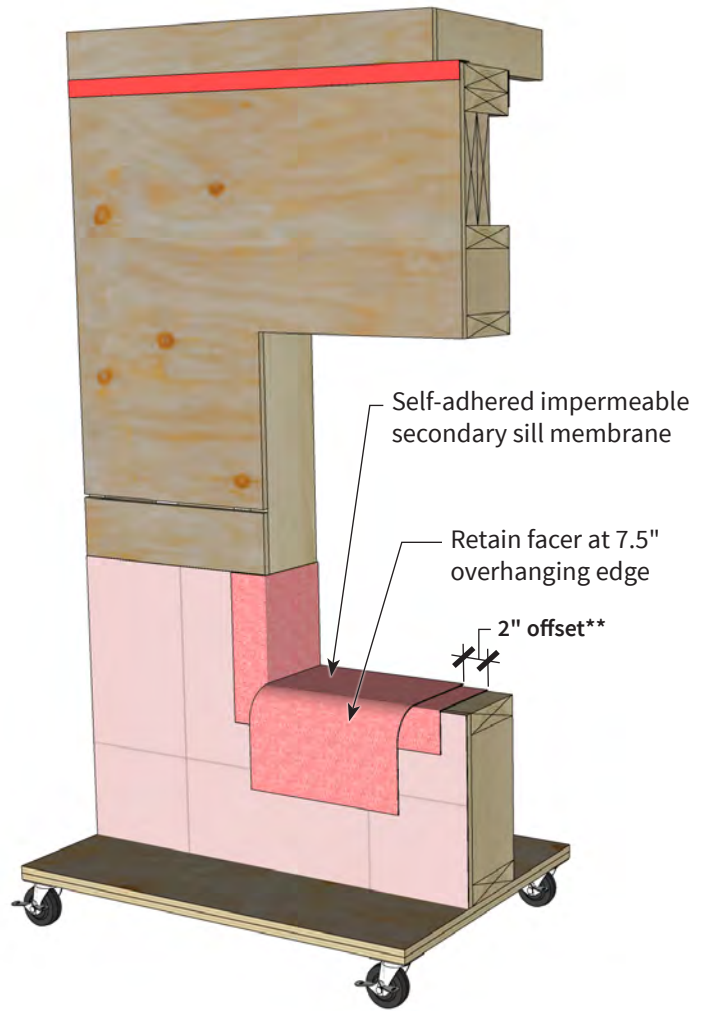
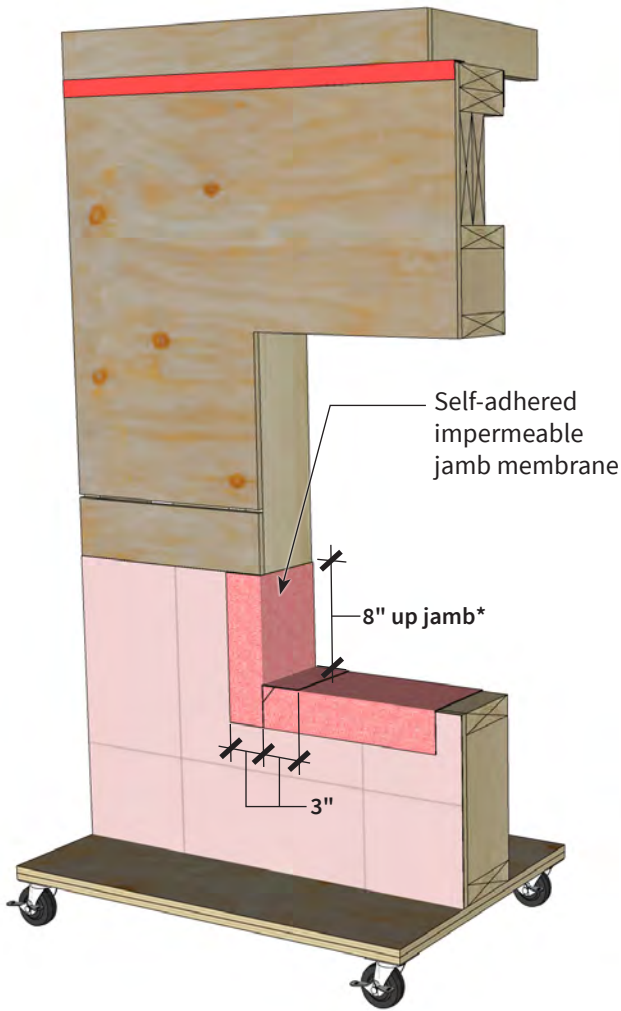

*Recommended dimension for correct membrane lapping.

**Recommended dimension for offset layering.

Window Pre-Strip Sheathing Membrane

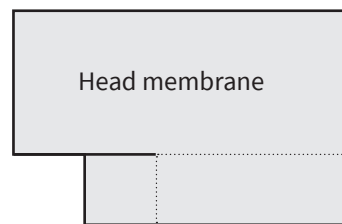
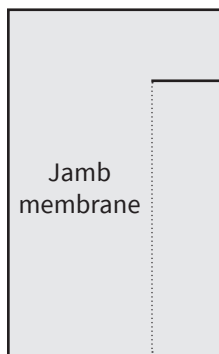
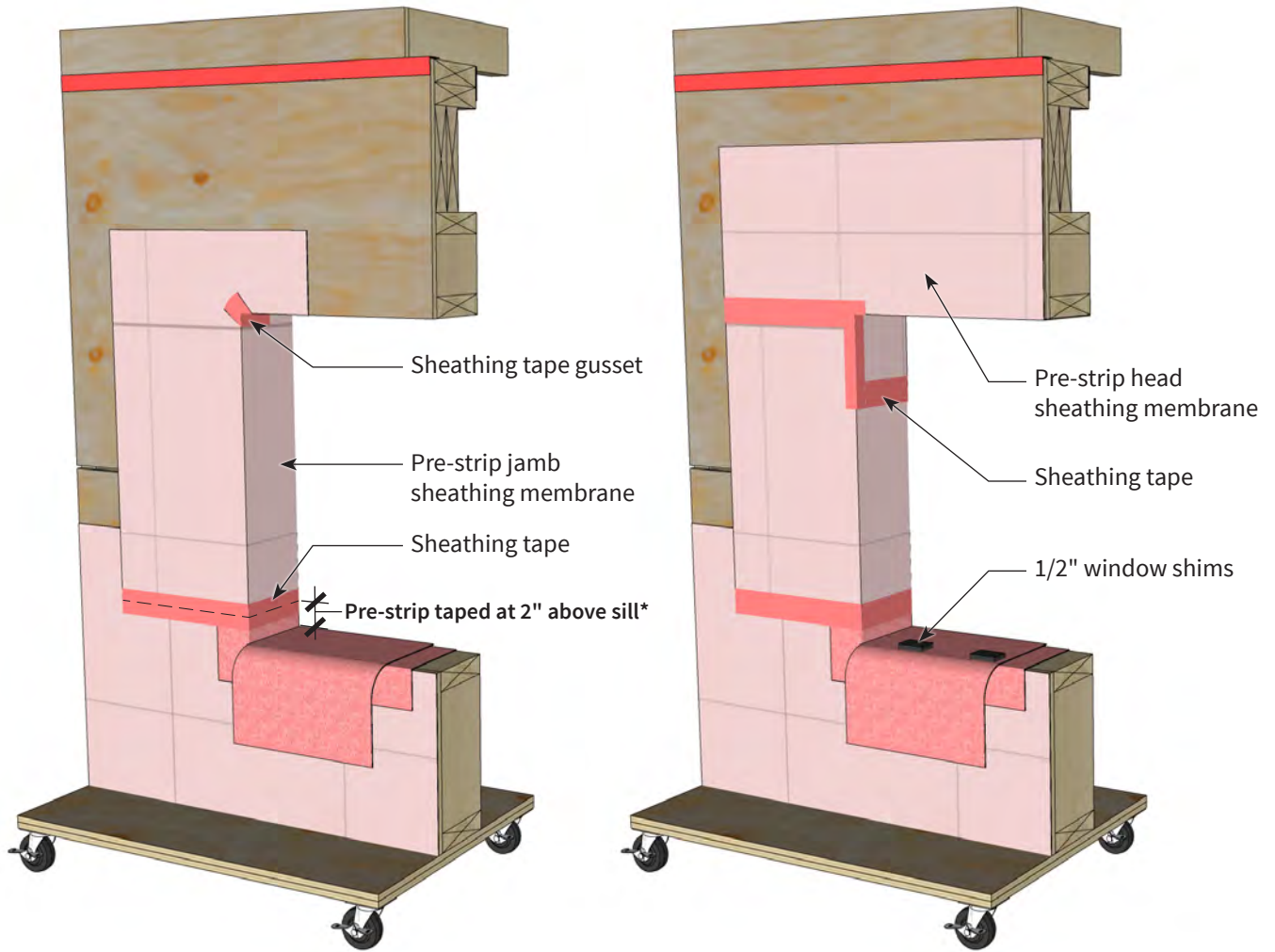

*Recommended dimension for correct membrane lapping.

Window Installation

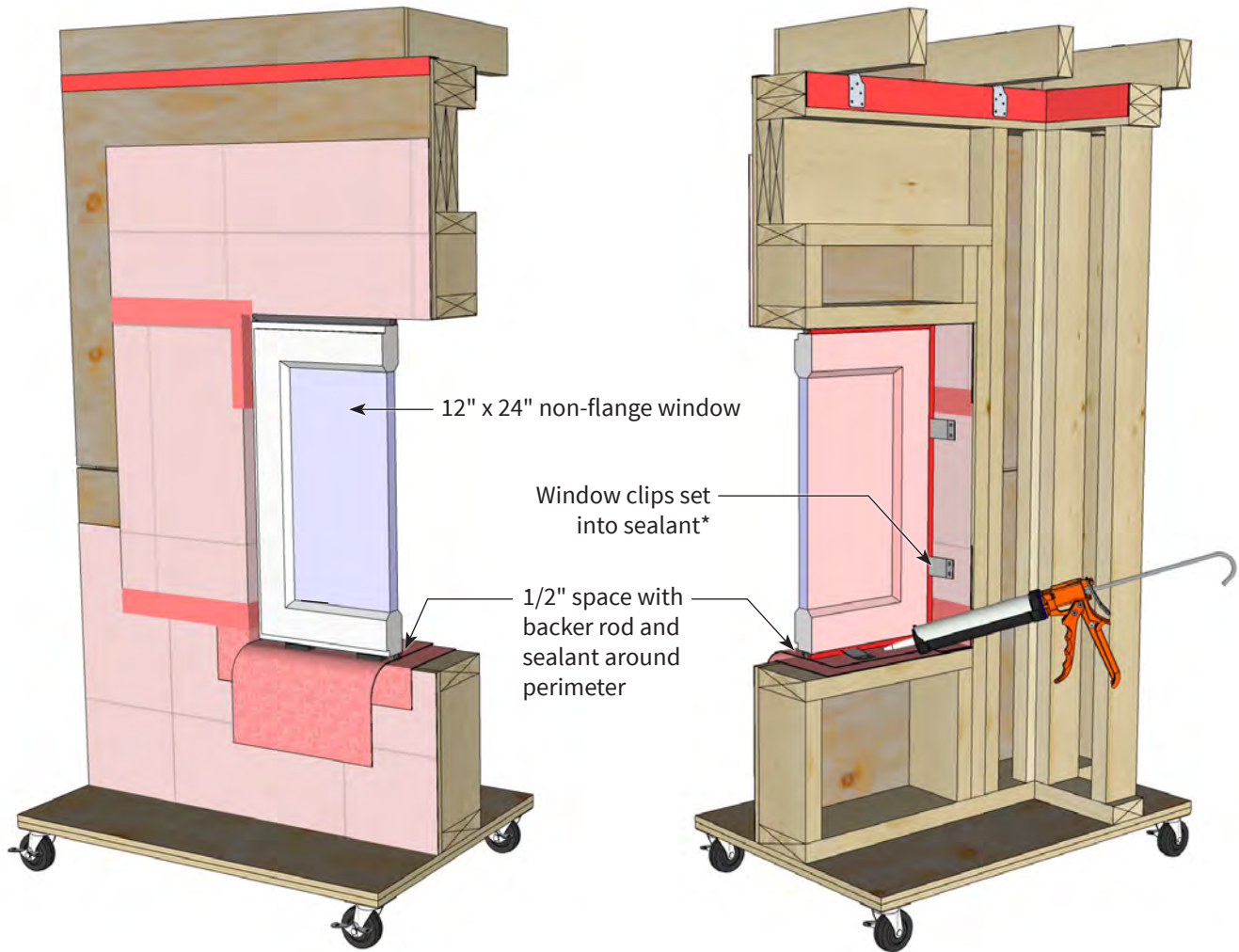

*As per manufacturer's installation requirements.

Field Membrane & Insulation

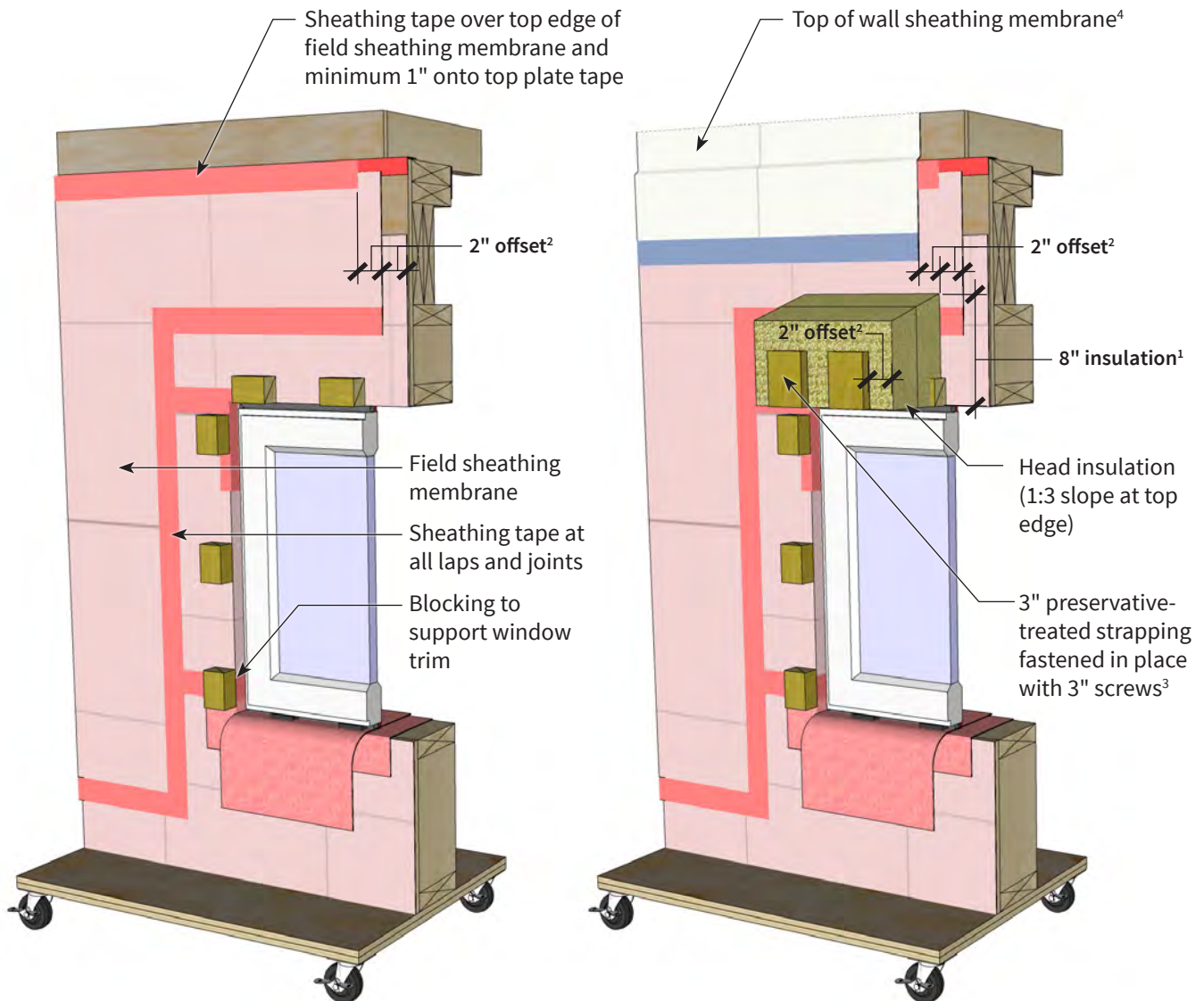

¹Varies based on trim and flashing dimensions; recommended dimension for use with 5-1/2" trim board at head.

²Recommended dimension for offset layering.

³Strapping spaced to retain mockup insulation as needed.

⁴The top of wall sheathing membrane above the top plate functions only as the water-resistive barrier in this assembly and must be installed following the manufacturer's instructions.

Insulation & Strapping

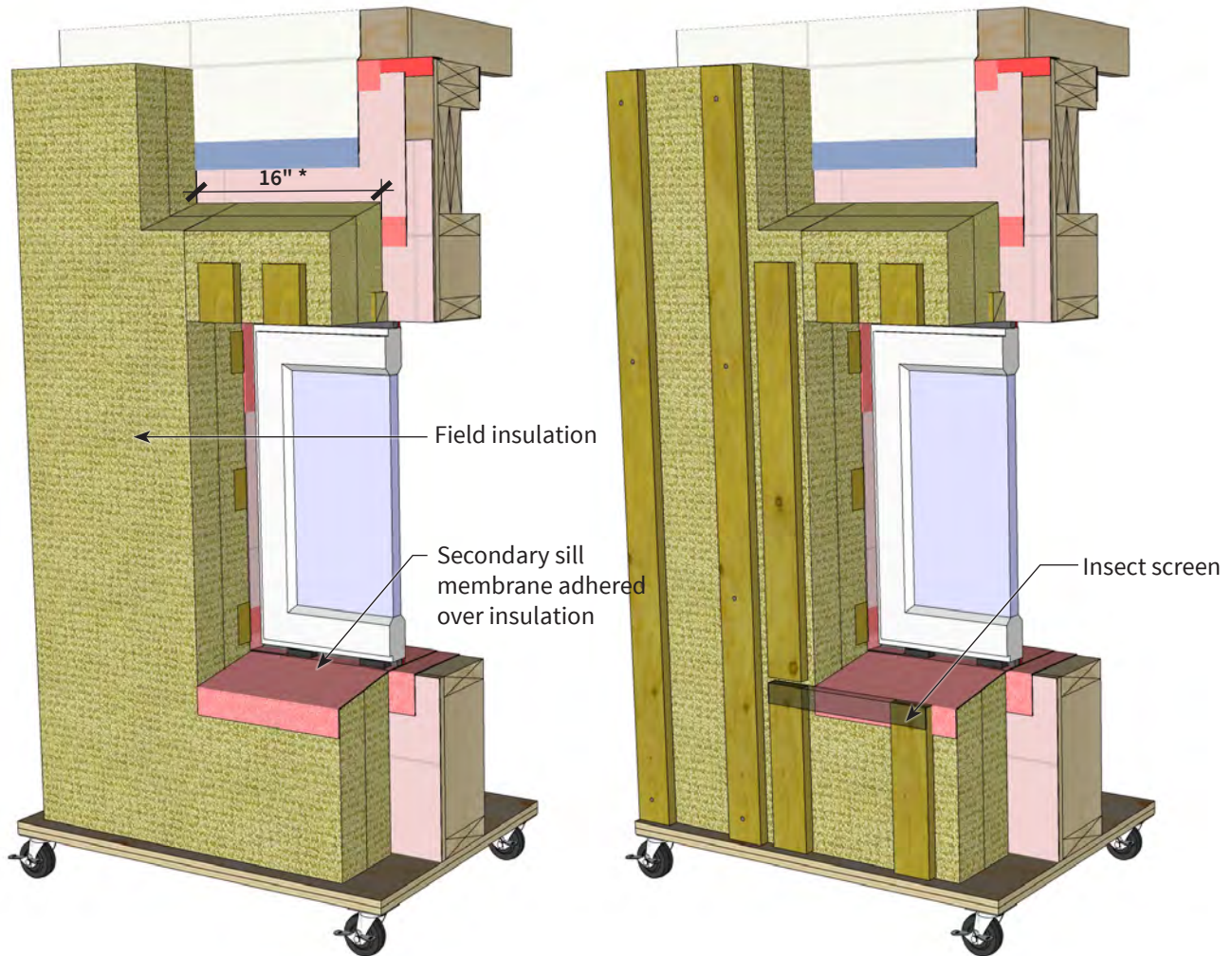

*Varies based on trim used; recommended dimension to align with outside edge of 5-1/2" trim board at jamb inset 1-1/2" over window.

Flashing & Trim

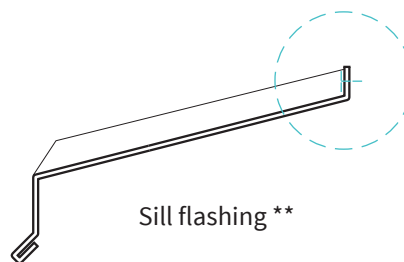
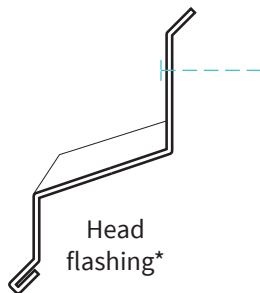
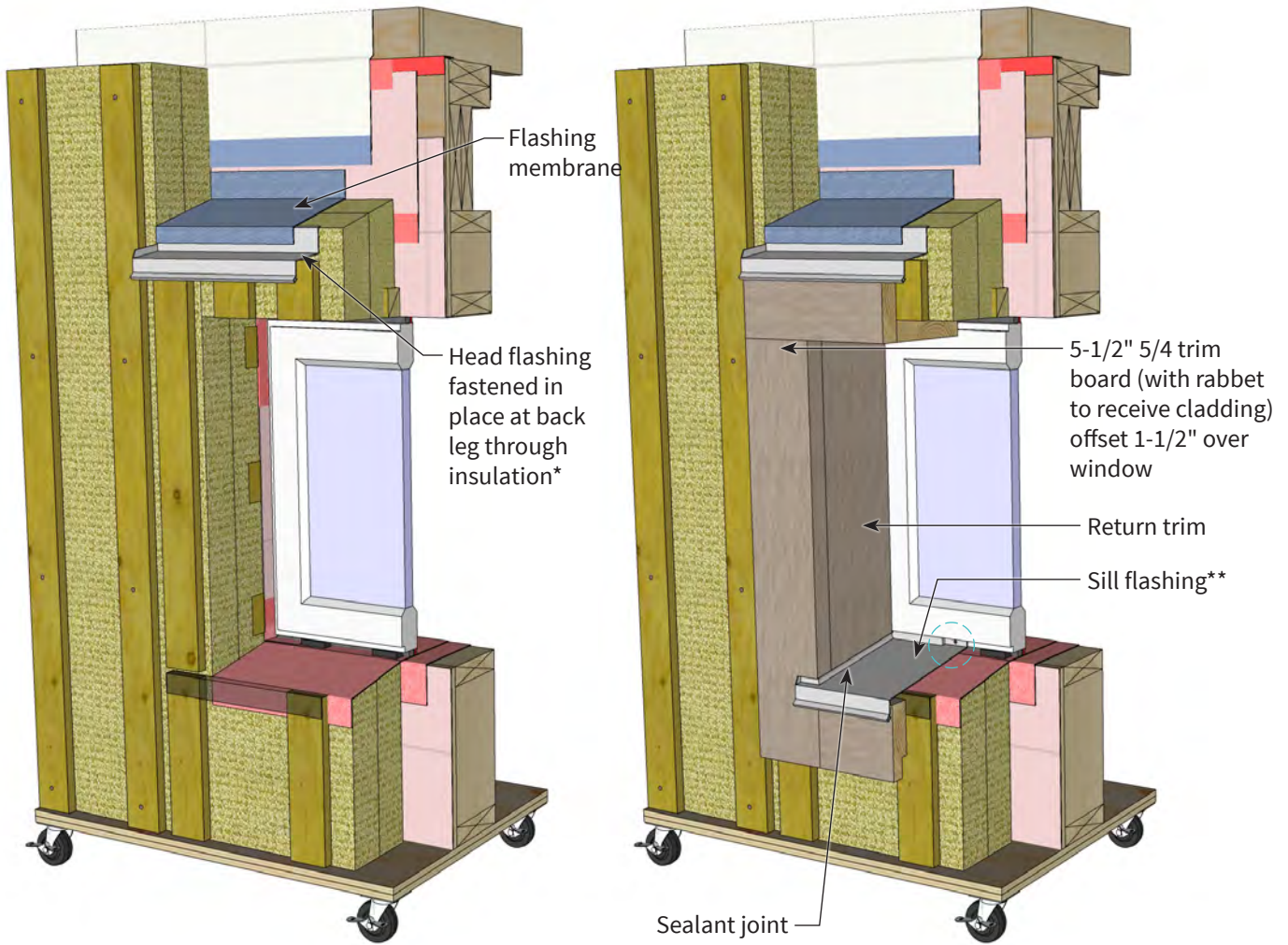

*Flashing profile varies based on trim thickness.

**Sill flashing attachment to window varies; profile shown assumes back leg attachment to front face of window with screws. Other options include attachment with double-sided tape and sealant, or using an extended return beneath the window profile.

Strapping & Cladding

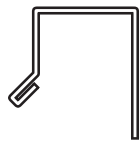
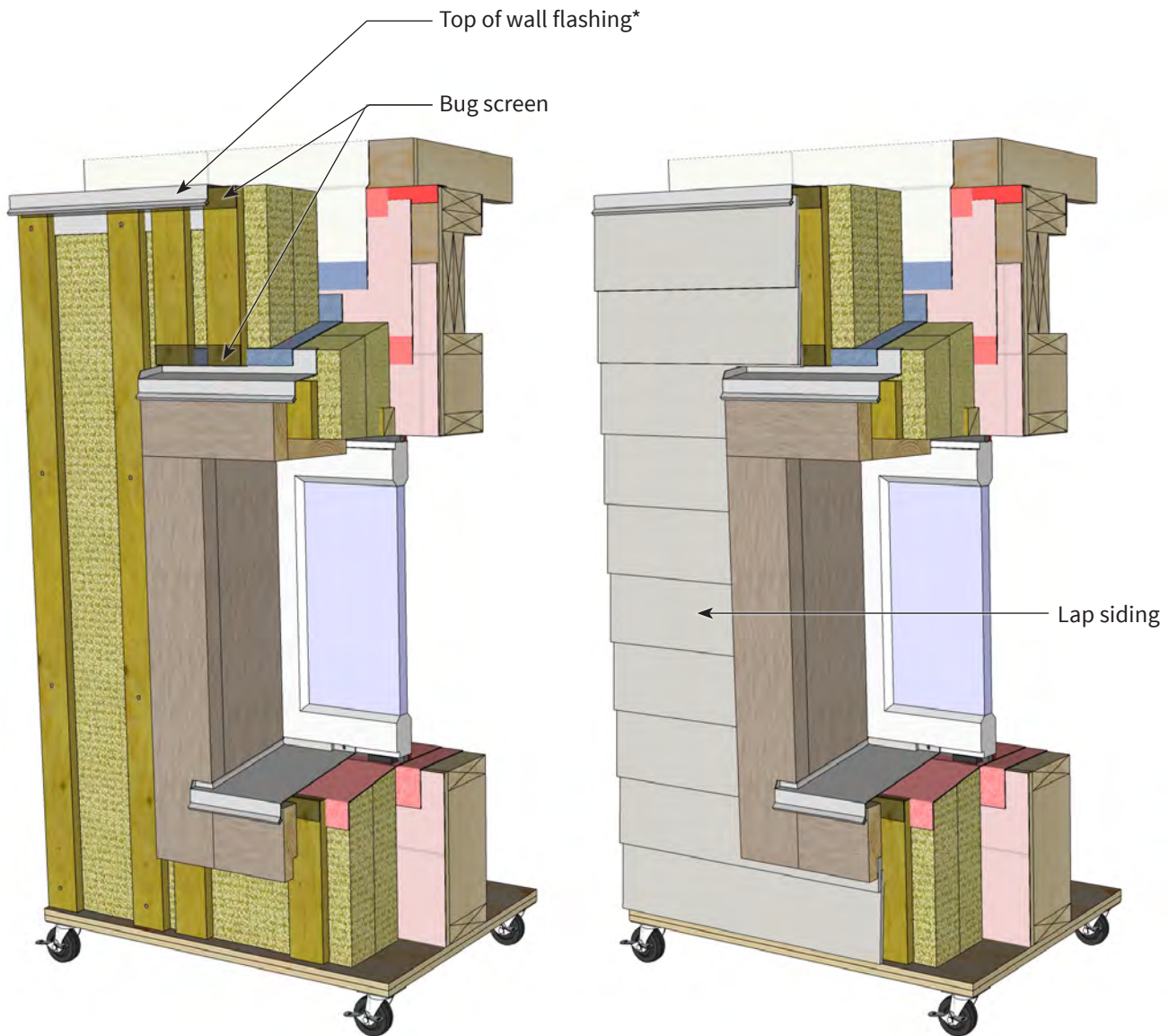

Top of wall flashing*

*Profile varies based on trim/cladding used; must be shaped to cap-off top of rainscreen cavity but still allow ventilation. Attached by slipping between back of strapping and front face of exterior insulation.

Interior Insulation & Polyethylene

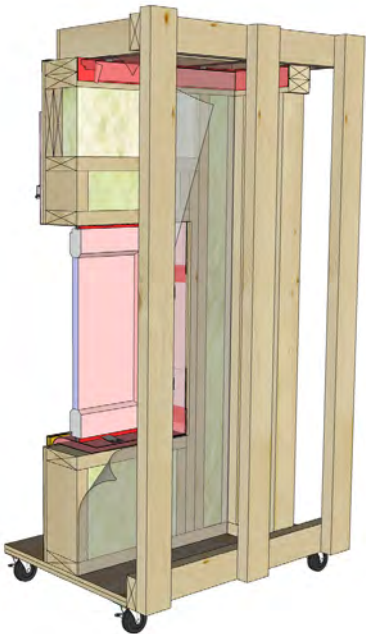
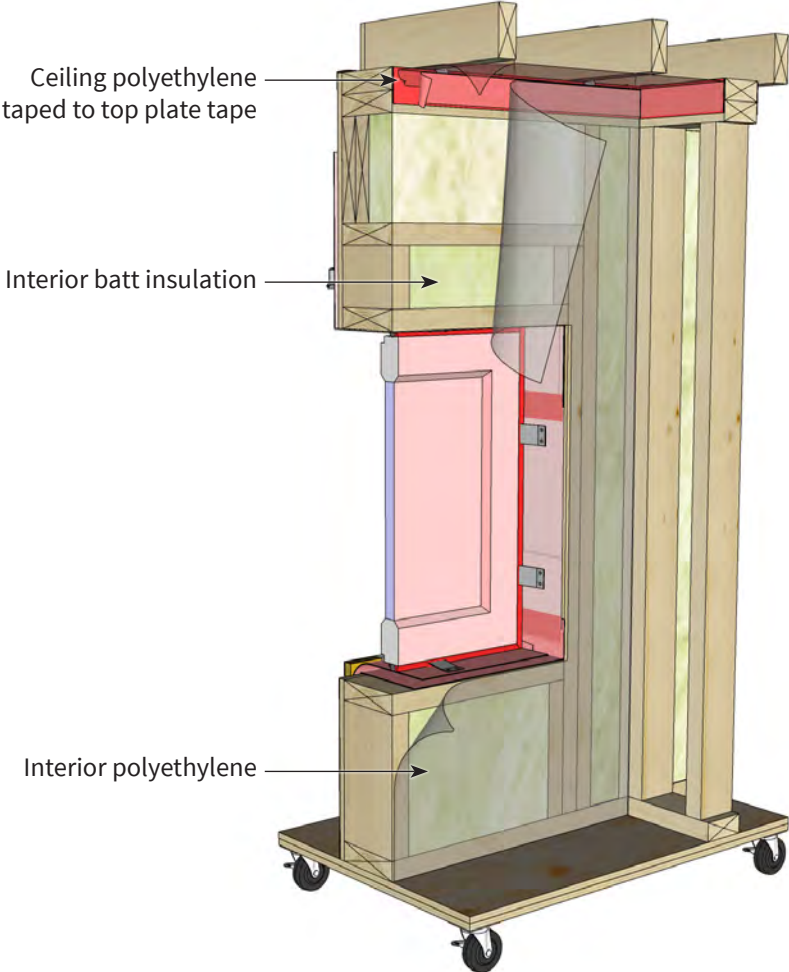

This page is intentionally left blank

Deep Stud-Insulated Wall Assembly

Non-Flange Window | Exterior Air and Barrier Approach

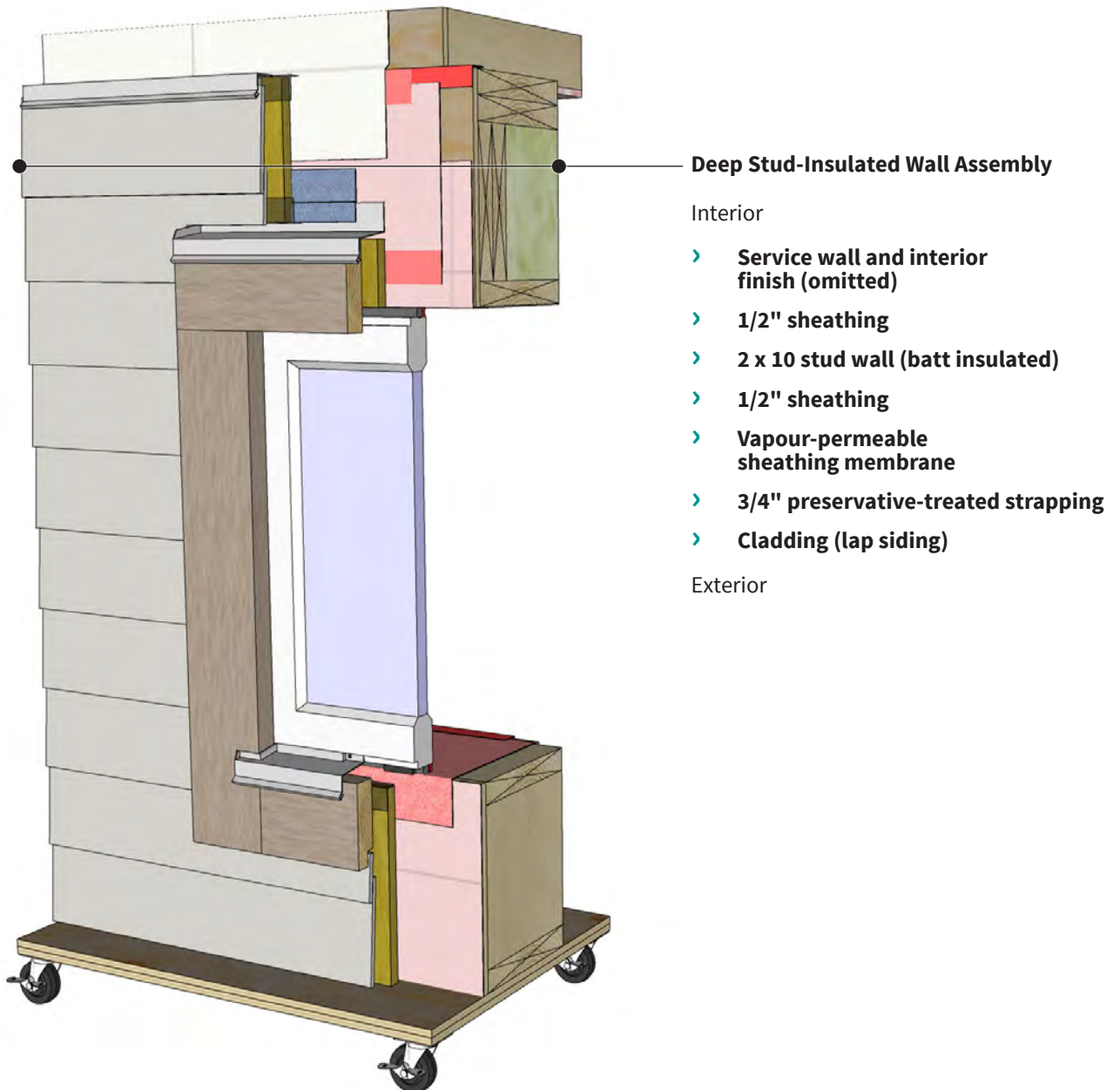

Materials & Tools

Materials

- › 30 lf. 2x10 lumber for exterior wall framing
- › 36 lf. 2x4 lumber for interior wall & shipping framing
- › 3 lf. 2x8 lumber for header framing
- › 18 lf. 1-1/2" wide x 3/4" thick preservative-treated plywood rainscreen strapping
- › 48" x 96" 1/2" plywood sheet
- › 15 lf. 7-1/4" wide fibre-cement lap siding
- › 4 lf. 5-1/2" wide 5/4 trim board
- › 4 lf. insect screen
- › 4 lf. 9" wide 24 gauge flashing flatstock
- › 12" x 27-3/4" window (W x H, with attachment accessories as required)
- › **(4)** 3" non-marking lockable casters
- › 4 lf. backer rod for 1/2" gap
- › Contractor-grade silicone sealant
- › 5 lf. 12" wide impermeable self-adhered membrane
- › Roll of 2-1/2" wide high-performance air barrier tape
- › 48" x 96" 1/2" OSB sheet
- › 6 lf. 2x10 stud batt insulation
- › Assorted window shims
- › **(3)** Hurricane ties
- › 48" x 72" permeable sheathing membrane
- › Roll of 2-1/2" wide sheathing tape
- › Assorted fasteners including:
 - Framing nails
 - 8" wood screws
 - Cladding nails
 - Staples

Tools

- › Standard tools for framing, cladding and flashing work
- › 24" sheet metal brake
- › Staple gun
- › Sealant gun
- › Membrane roller
- › Utility knife

Framing Cut List

Base Platform (1/2" plywood)

- › (2) 24" x 33" rectangle

Exterior Wall (2x10 lumber unless noted otherwise)

- › 33" bottom plate
- › (2) 10-1/2" cripple
- › 40-3/4" trimmer stud
- › 51-1/2" king stud
- › 51-1/2" end stud
- › 16-1/2" sill
- › 18" header plate
- › 33" top plate
- › 6" top plate
- › 12-1/2" top plate
- › 11" top plate
- › 51-1/2" 2x6 interior wall backer stud
- › (2) 18" 2x10 header

Interior Wall, Ceiling & Shipping (2x4 lumber)

- › 6" bottom plate
- › 6" top plate
- › 15-3/4" overlapping top plate
- › (2) 51-1/2" studs
- › (3) 15-3/4" ceiling joists
- › (2) 33" shipping horizontal members
- › (3) 60-1/2" shipping vertical members

Exterior Sheathing (1/2" plywood)

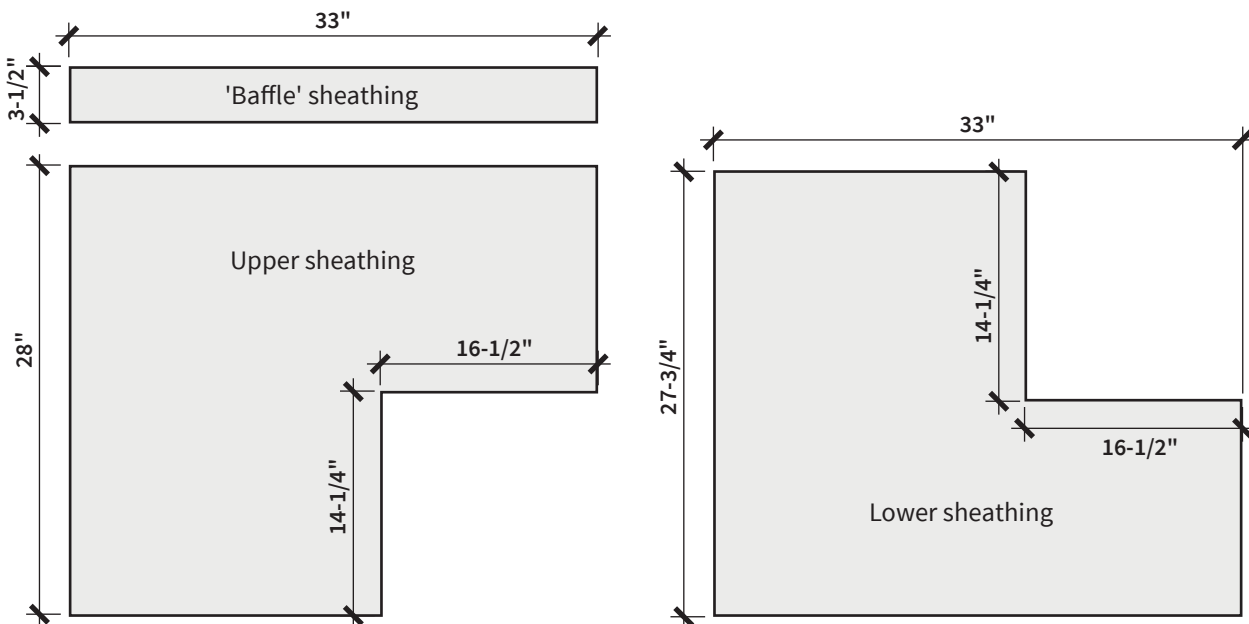

Exterior Wall Framing

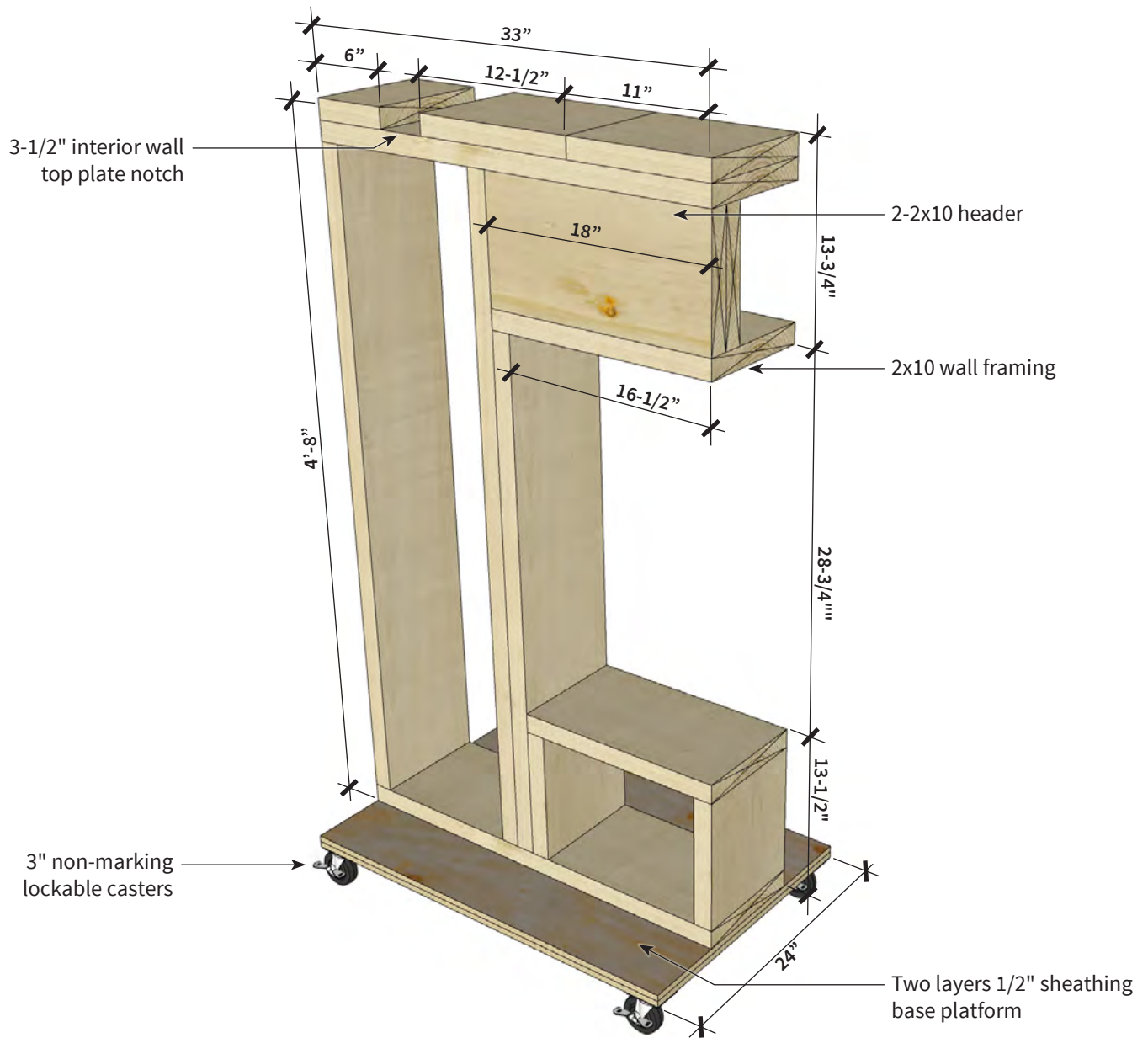

Wall Sheathing



Interior Wall Framing

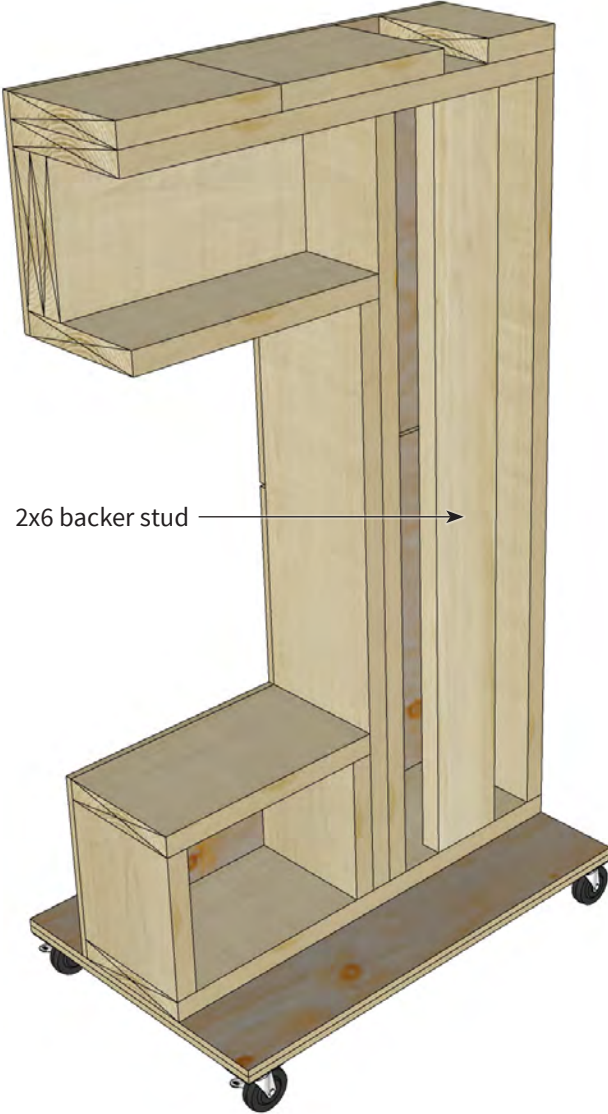

Top Plate Air Barrier Tape - Ceiling Interior Air Barrier Transition

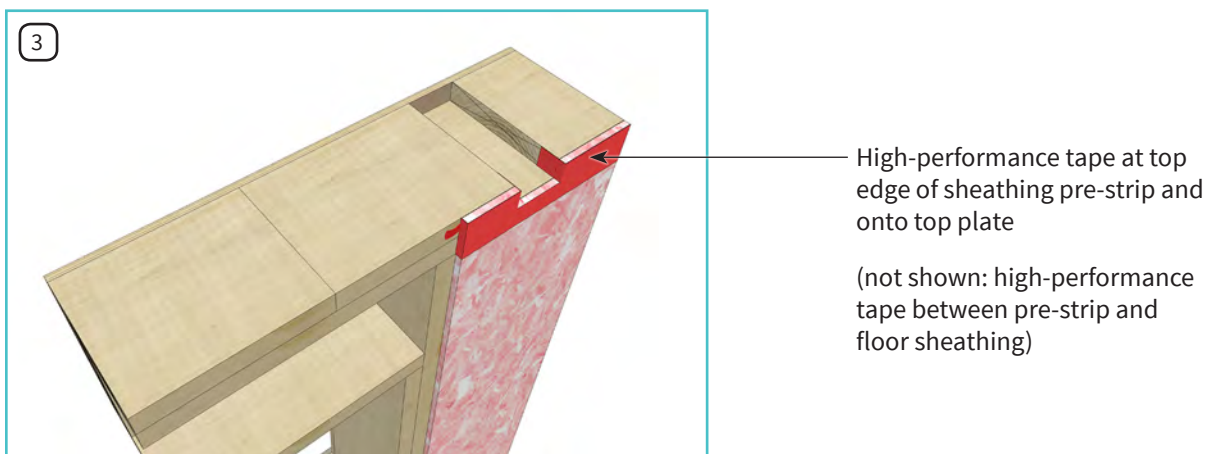
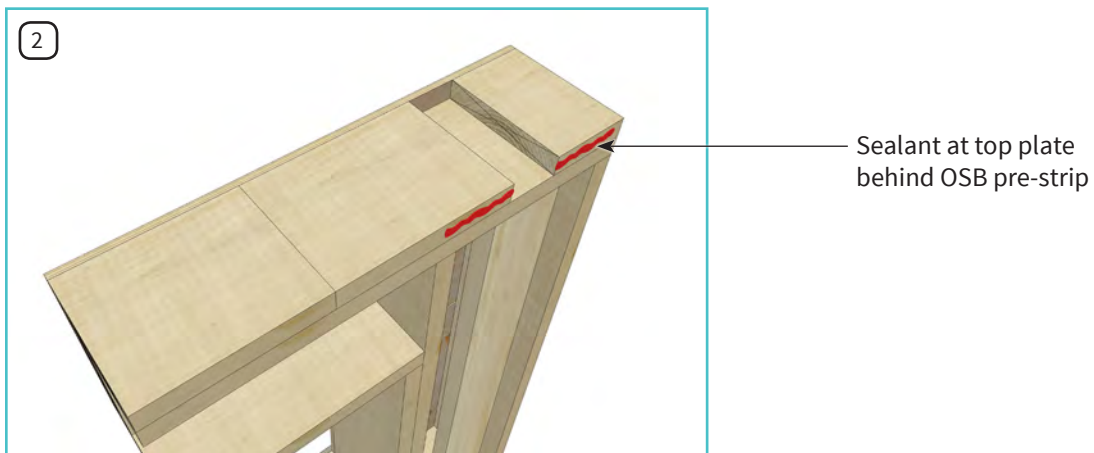
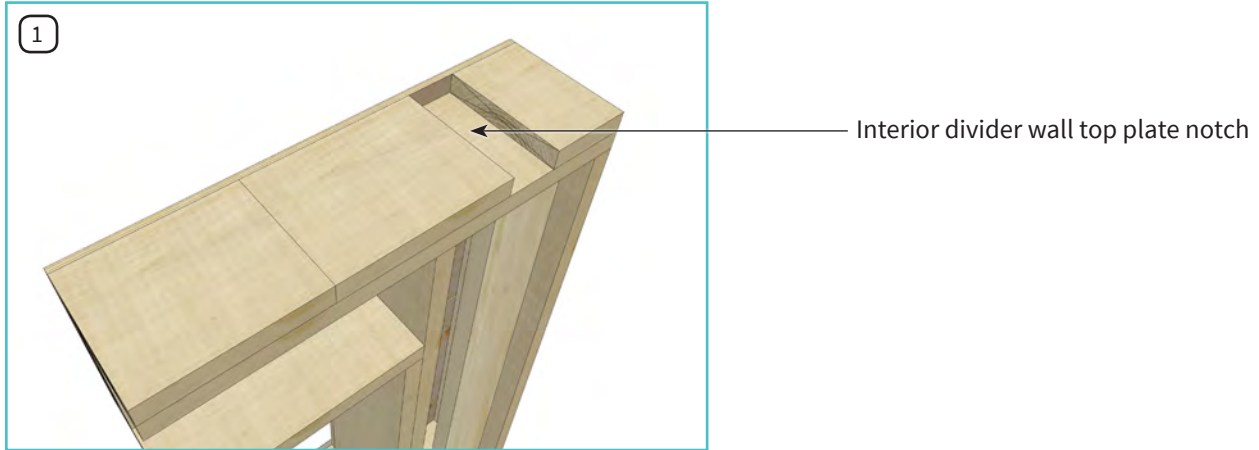

*Red indicates air barrier components, not necessarily product colour.

Top Plate Air Barrier Tape - Ceiling Interior Air Barrier Transition

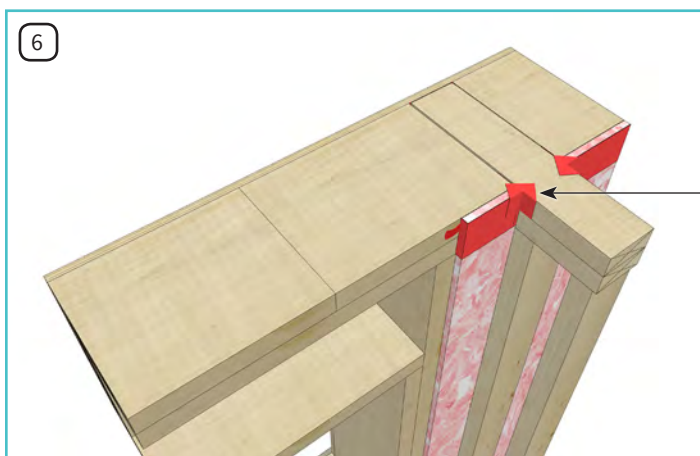
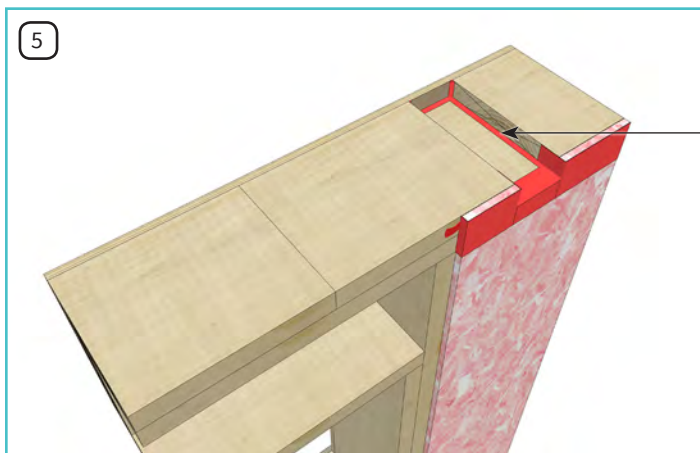
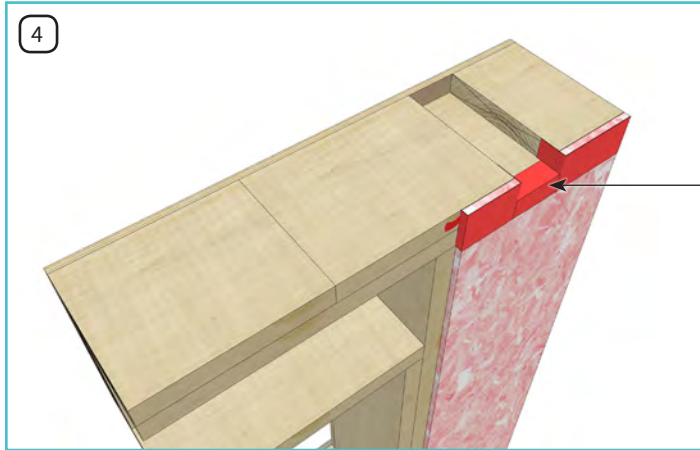

*Red indicates air barrier components, not necessarily product colour.

Top Plate Air Barrier Tape - Ceiling Interior Air Barrier Transition

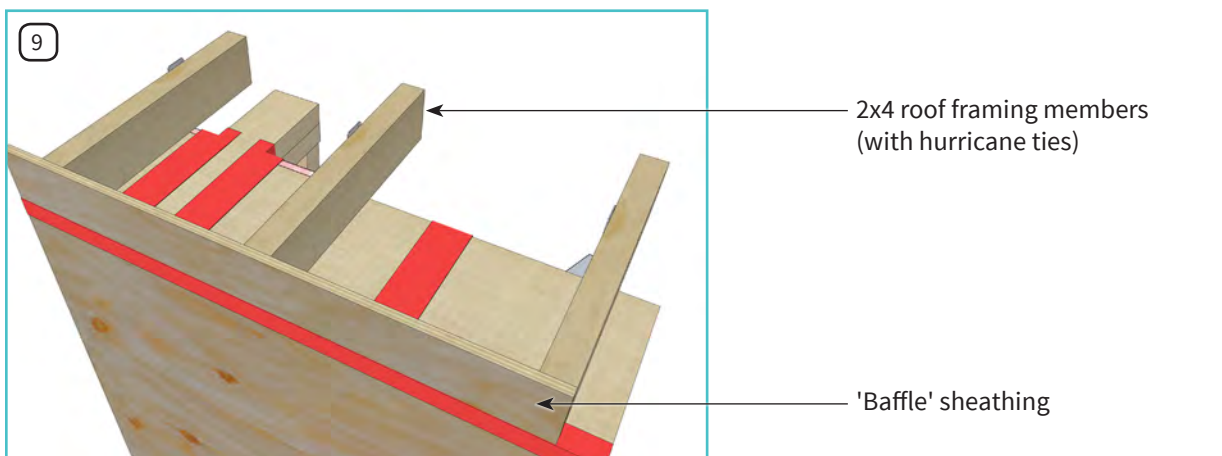
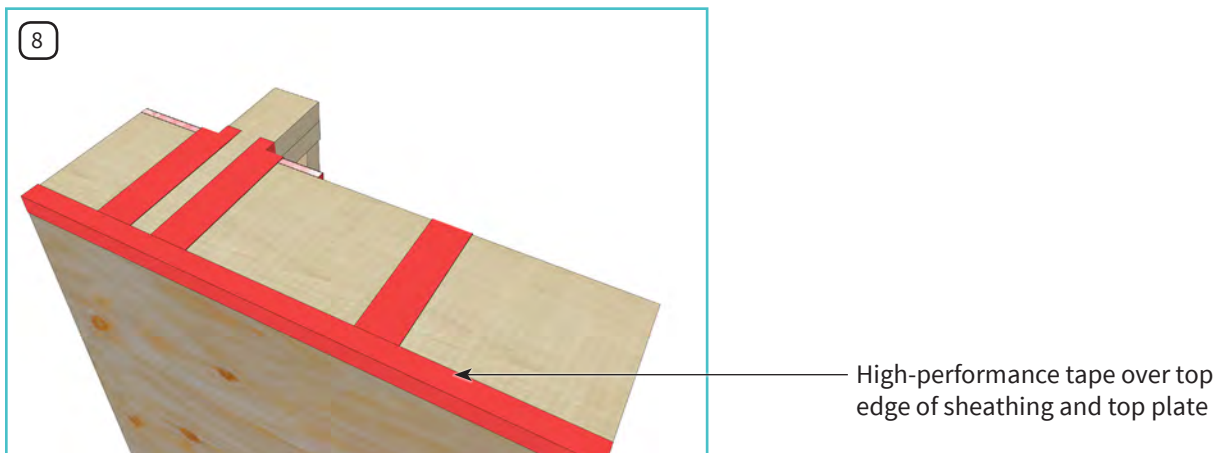
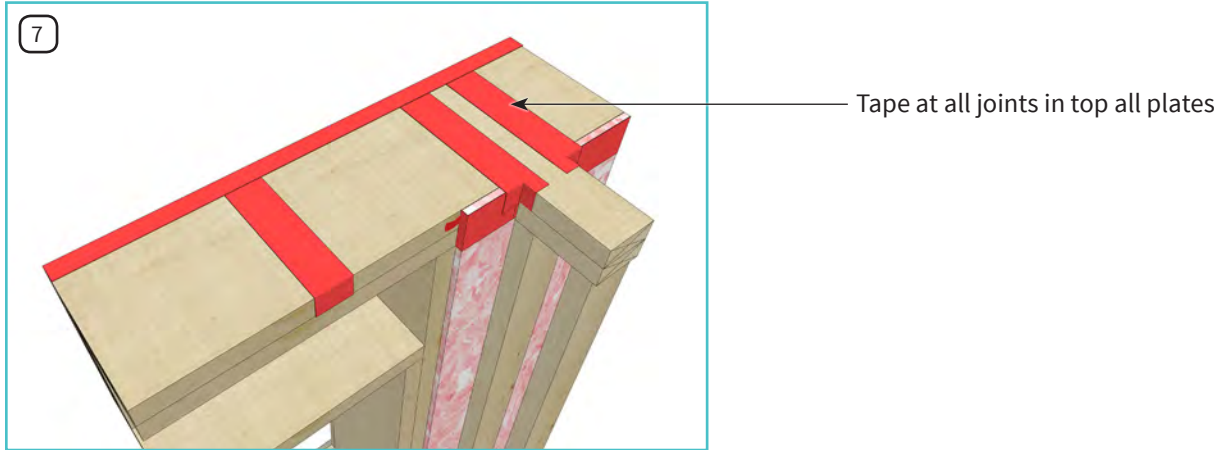

*Red indicates air barrier components, not necessarily product colour.

Window Sill Pre-Strip Sheathing Membrane & Self-Adhered Membrane

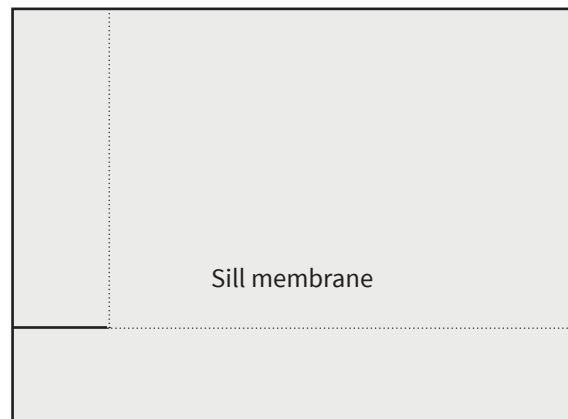
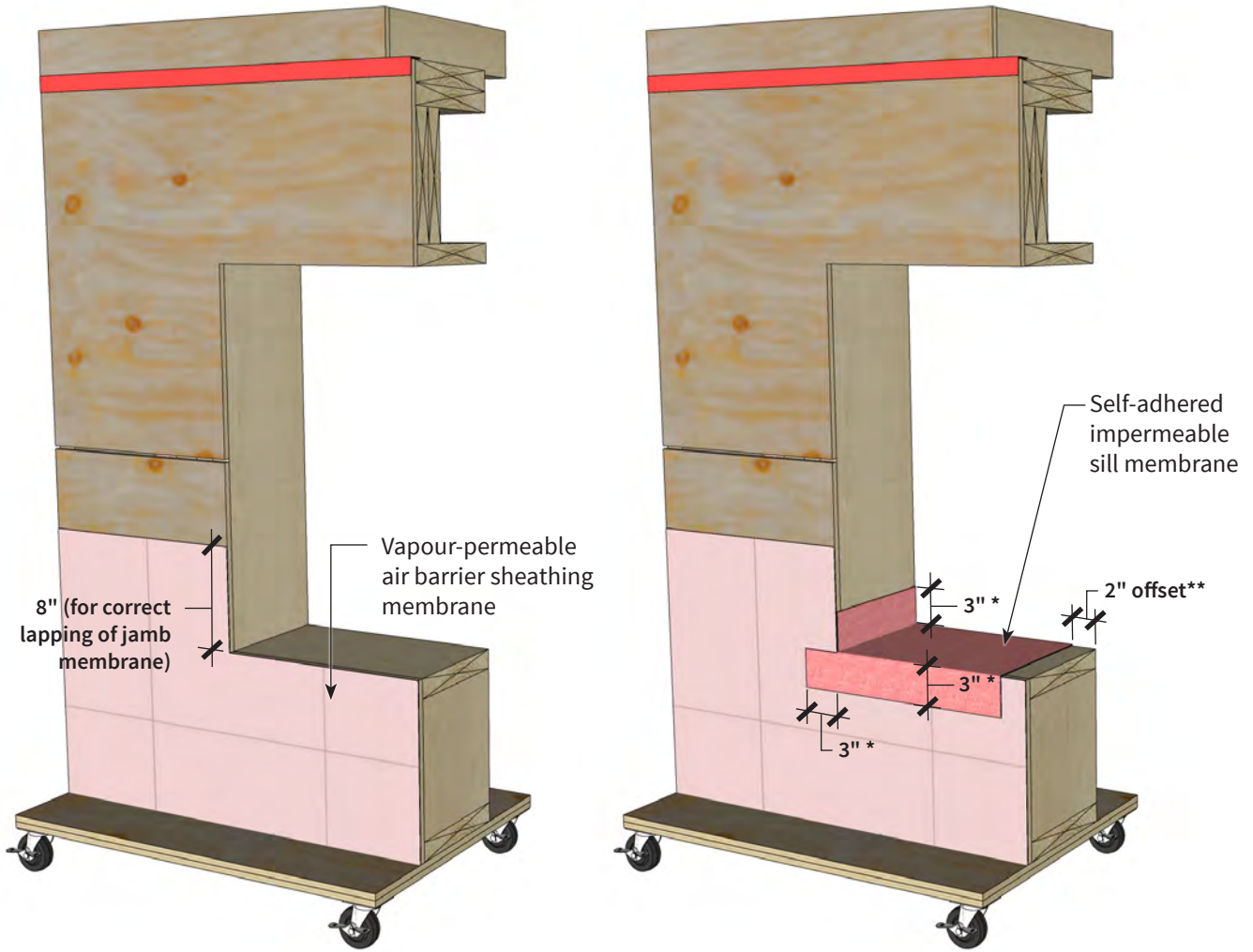

*Recommended dimension for correct membrane lapping.

**Recommended dimension for offset layering.

Window Self-Adhered Membrane

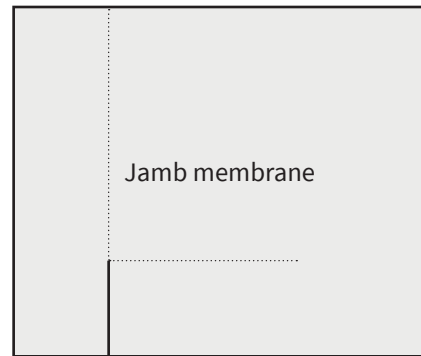
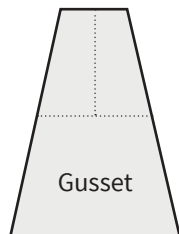
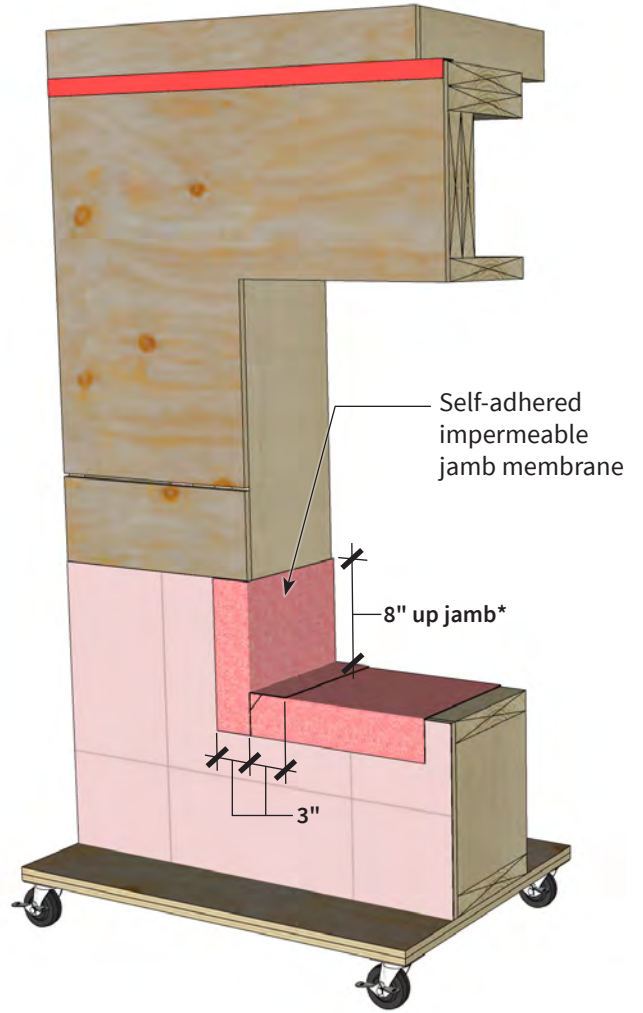
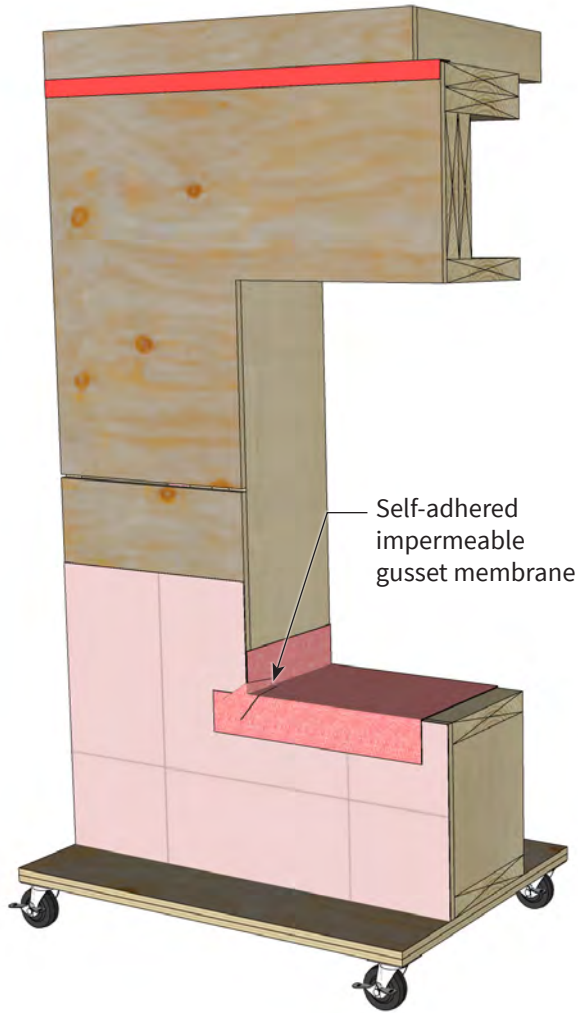

*Recommended dimension for correct membrane lapping.

Window Pre-Strip Sheathing Membrane

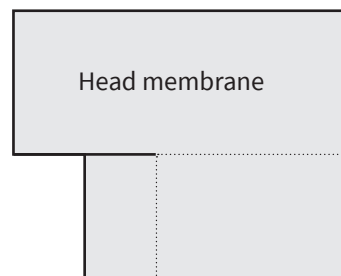
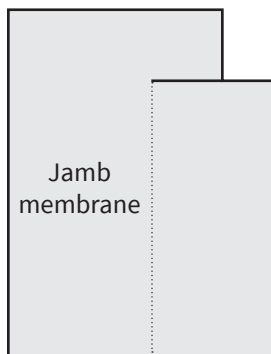
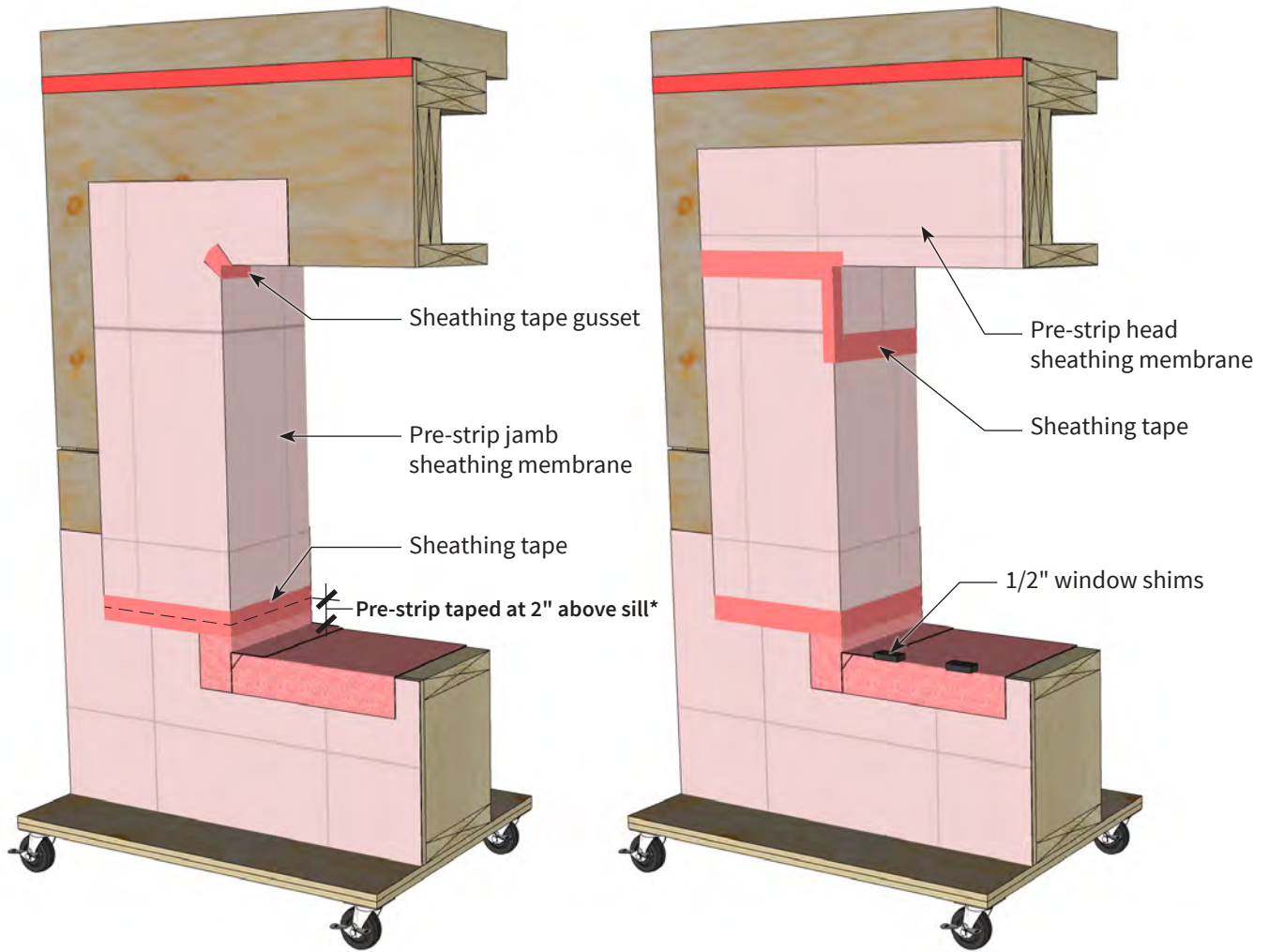

*Recommended dimension for correct membrane lapping.

Window Installation

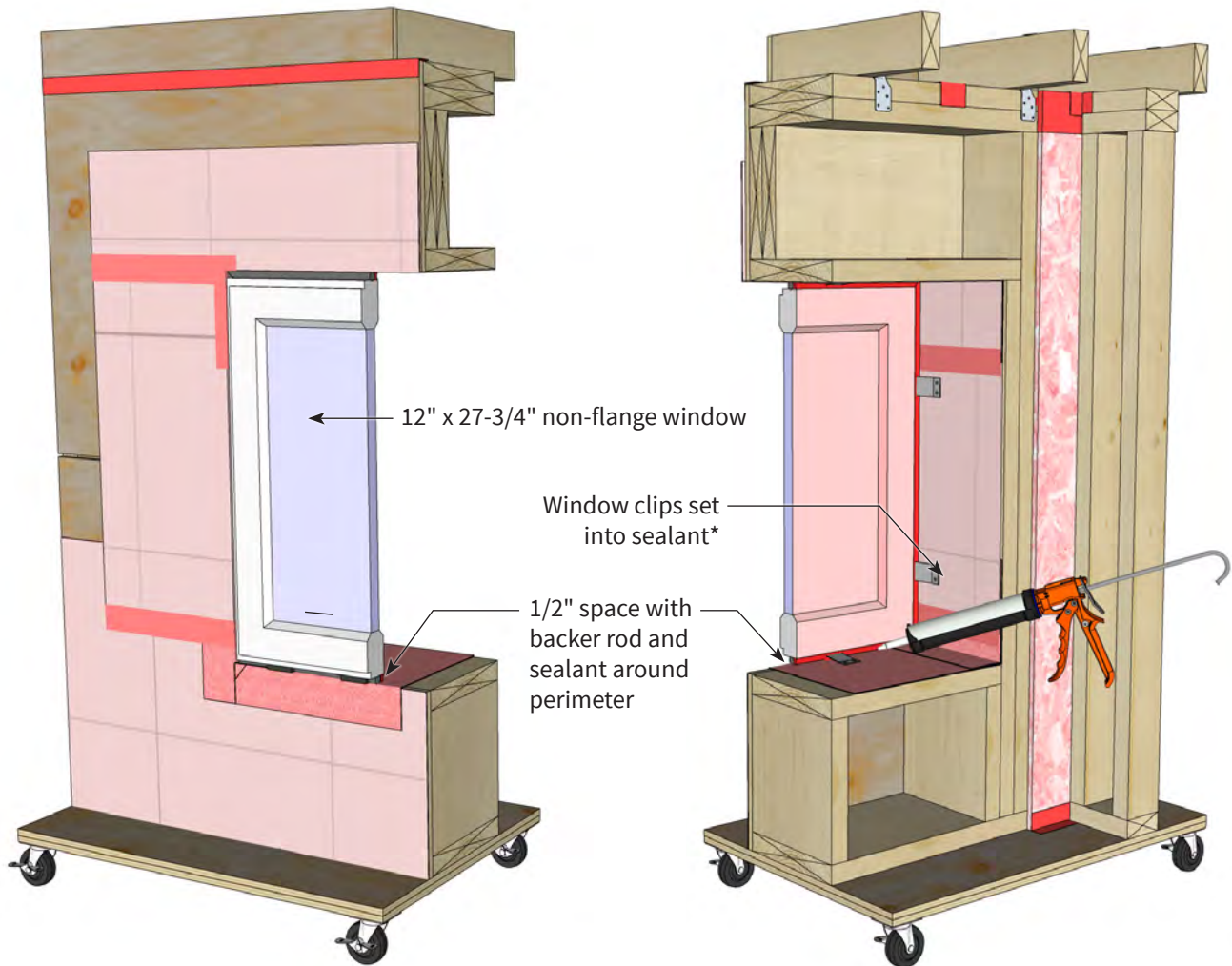

*As per manufacturer's installation requirements.

Field Membrane & Strapping

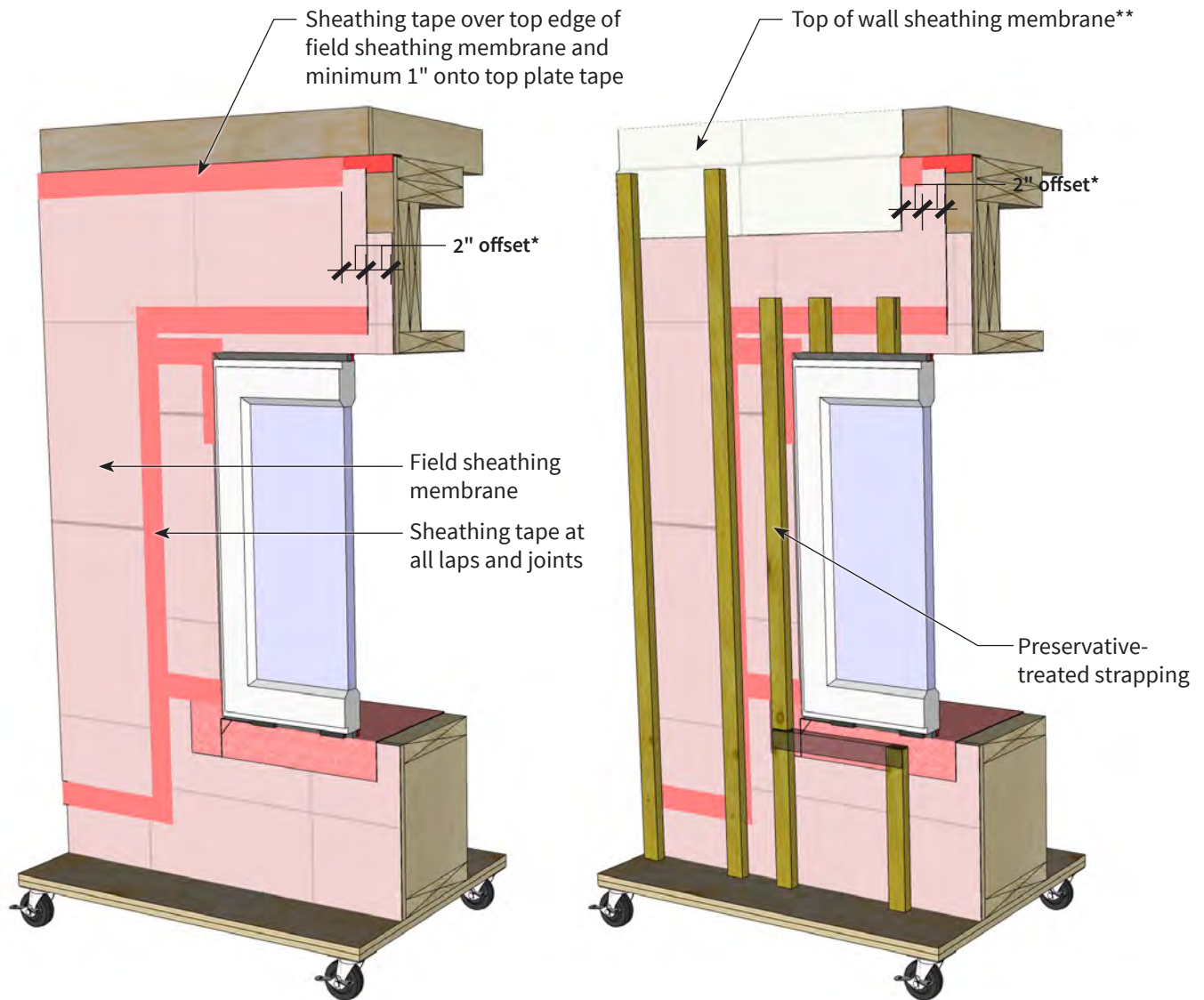

*Recommended dimension for offset layering.

**The top of wall sheathing membrane above the top plate functions only as the water-resistive barrier in this assembly and must be installed following the manufacturer's instructions.

Flashing & Trim

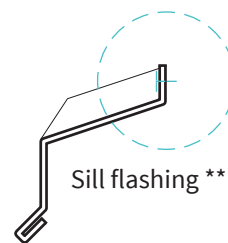
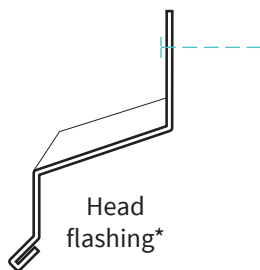
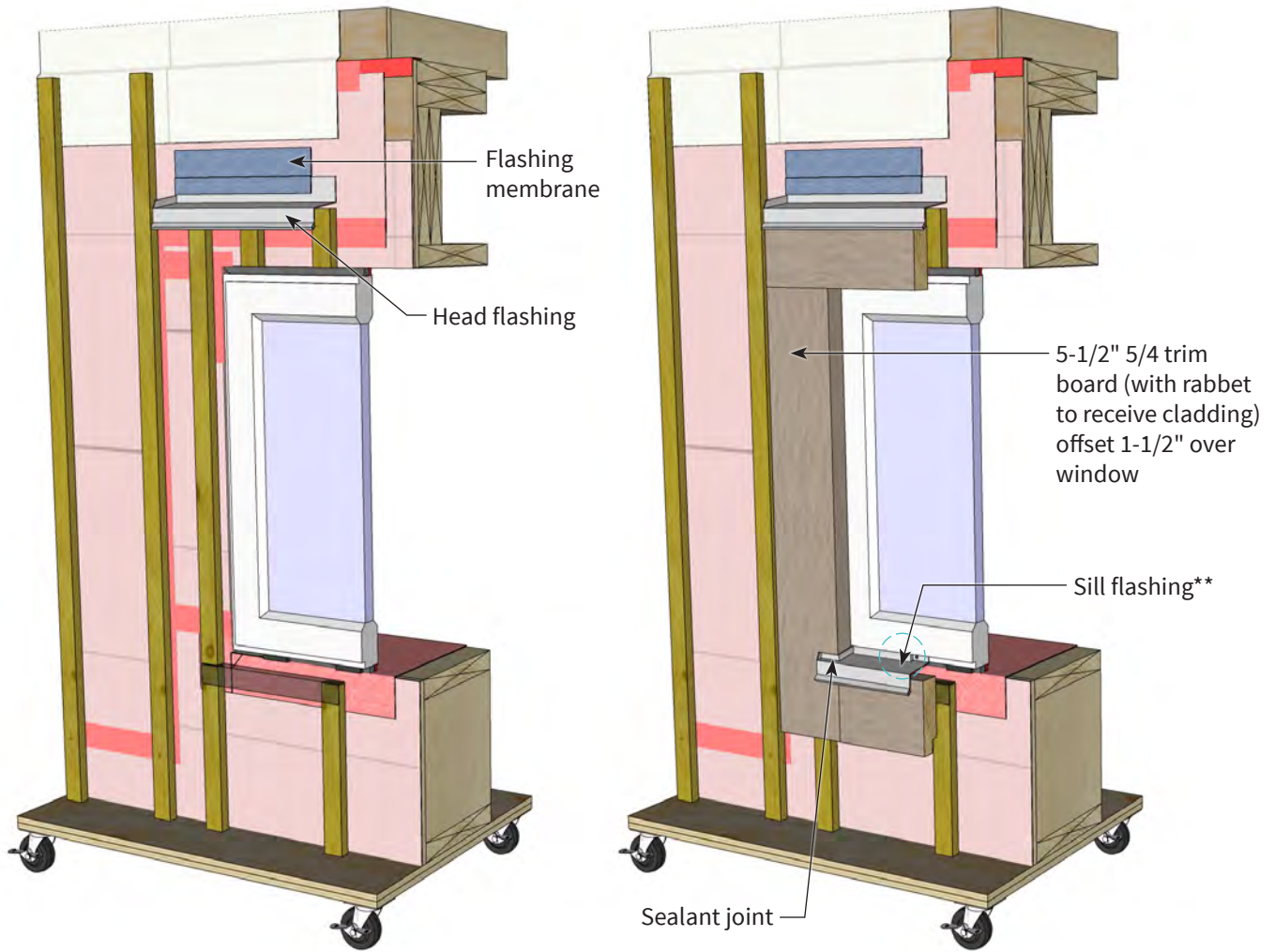

*Flashing profile varies based on trim thickness.

**Sill flashing attachment to window varies; profile shown assumes back leg attachment to front face of window with screws. Other options include attachment with double-sided tape and sealant, or using an extended return beneath the window profile.

Strapping & Cladding

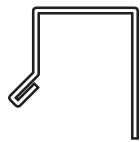
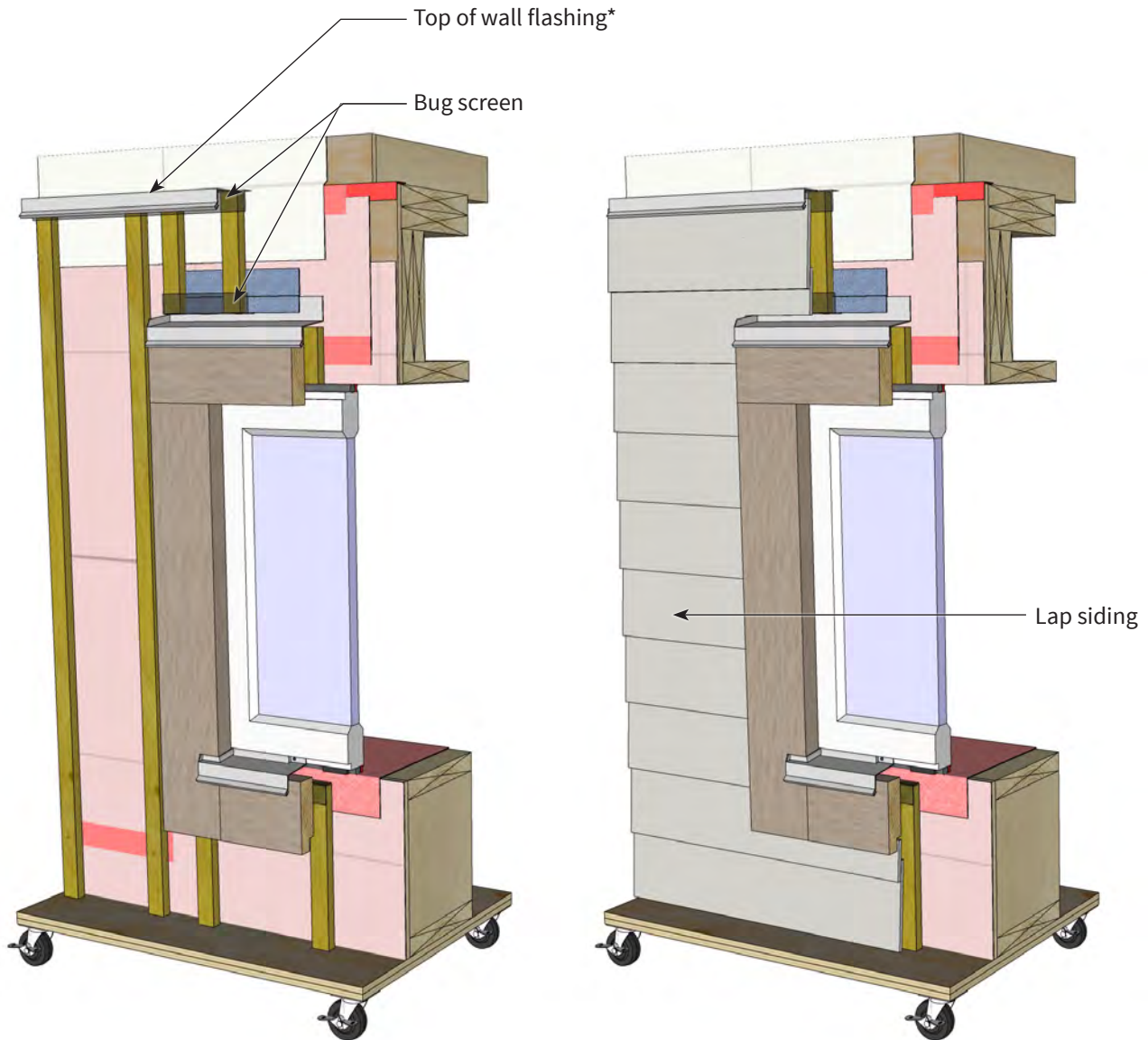

Top of wall flashing*

*Profile varies based on trim/cladding used; must be shaped to cap-off top of rainscreen cavity but still allow ventilation. Attached by slipping between back of strapping and front face of exterior insulation.

Interior Insulation & Wall Air Barrier

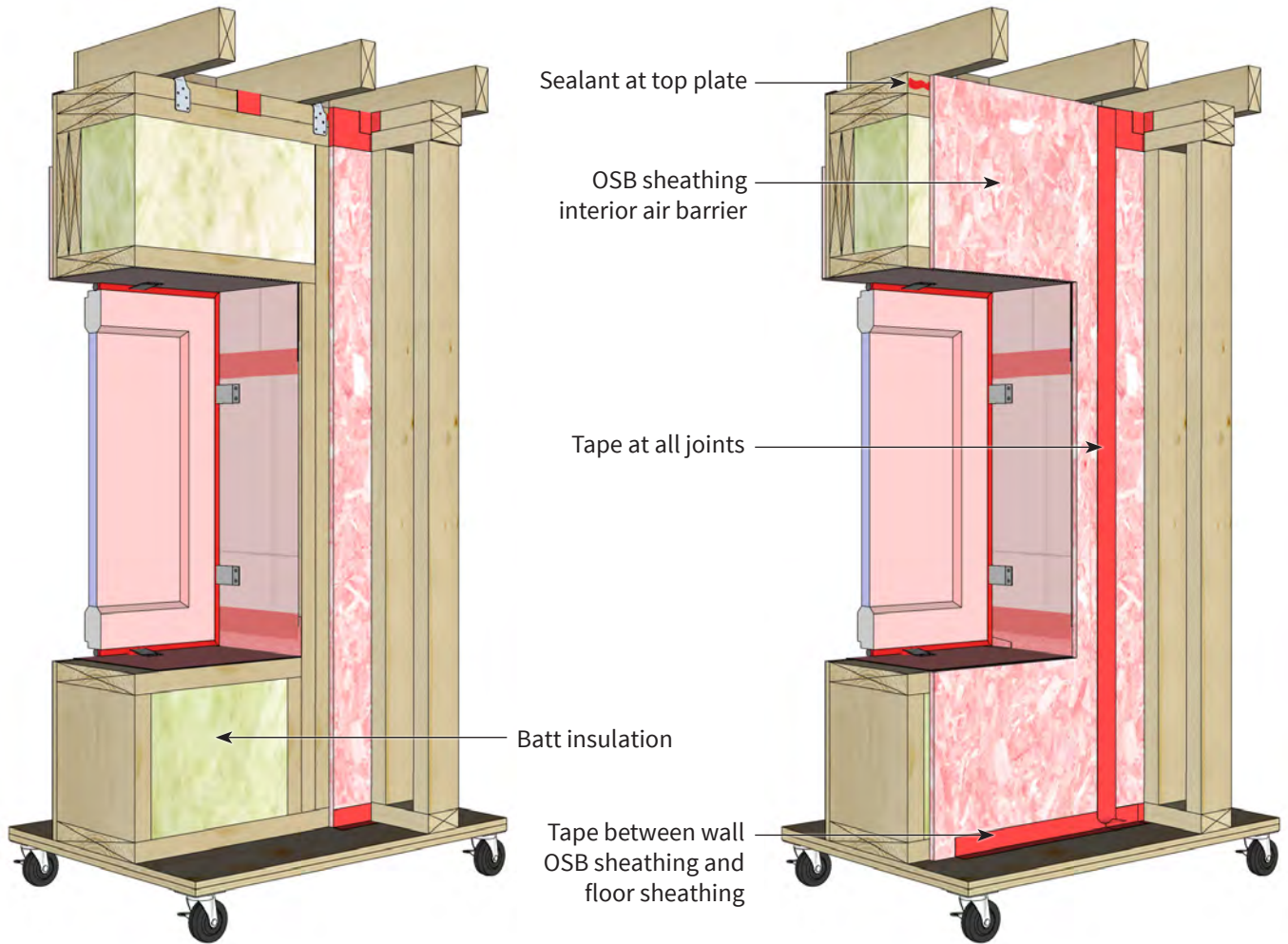

Interior Ceiling Air Barrier & Transport Framing

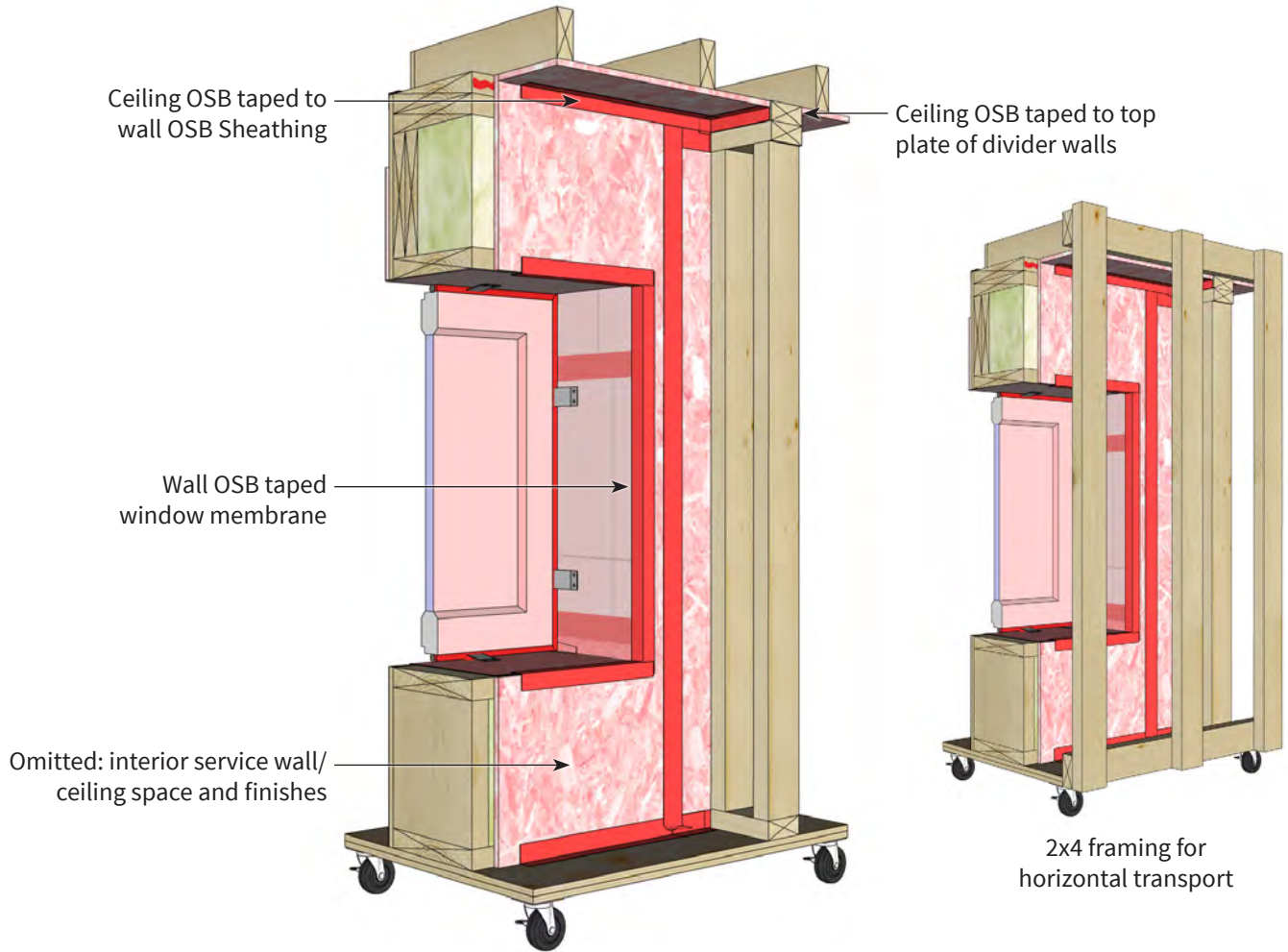



Research Centre
1701 – 4555 Kingsway
Burnaby, BC V5H 4V8
Phone: 778 452 6454
Toll-free: 1 866 465 6873
Email: technicalresearch@bchousing.org
www.bchousing.org